

PART NUMBER	REVISION	DESCRIPTION	FEED TYPE
2151833-1	C	FINE CRIMP HEIGHT ADJUST	MECHANICAL
2151833-2	C	FINE CRIMP HEIGHT ADJUST	PNEUMATIC
7-2151833-1	C	MECHANICAL AND CRIMP TOOLING KIT	MECHANICAL
7-2151833-2	C	PNEUMATIC AND CRIMP TOOLING KIT	PNEUMATIC
7-2151833-7	A	CRIMP TOOLING KIT	-

ATLANTIC VERSION TERMINATOR INTERFACE ADAPTER

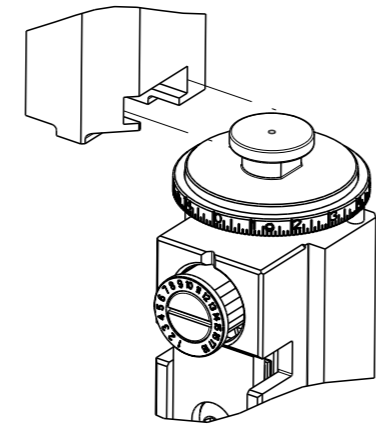

APPLICATOR DATA		
CRIMP	SIZE	TYPE
WIRE	1.60 mm [.063]	F
INSUL	1.60 mm [.063]	O

APPLICATOR INSTRUCTIONS 408-35042

TERMINAL DATA: JST TERMINAL		JST CRIMP SPECIFICATION	
TERMINAL NAME: TERMINAL FEMALE AIT 064 F.			
WIRE STRIP LENGTH		INSULATION DIAMETER RANGE	
4.00-4.50 mm [.157-.177 IN]		∅ 1.95mm MAX [.077 IN MAX]	
TERMINAL APPLICATION SPECIFICATION	JST Rev 1	-	-
TERMINALS APPLIED			
TE TERMINAL	JST TERMINAL	TE TERMINAL	JST TERMINAL
1832719-2	SAIT-A02T-M064	2113555-1	SAIT-A02GF-M064

TERMINAL DATA: JST TERMINAL		JST CRIMP SPECIFICATION	
TERMINAL NAME: TERMINAL FEMALE AIT 064 F.			
WIRE STRIP LENGTH		INSULATION DIAMETER RANGE	
4.00-4.50 mm [.157-.177 IN]		∅ 1.95mm MAX [.077 IN MAX]	
TERMINAL APPLICATION SPECIFICATION		-	-
TERMINALS APPLIED			
TE TERMINAL	JST TERMINAL	TE TERMINAL	JST TERMINAL
1832719-2	SAIT-A02T-M064		

WIRE SIZE	CRIMP HEIGHT mm [INCH]	CRIMP HEIGHT REFERENCE SETTING
18 AWG OR 0.85mm2	1.20+/-0.05 [.047+/- .002]	9.7
20 AWG OR 0.50mm2	1.05+/-0.05 [.041+/- .002]	10.5

WIRE SIZE	CRIMP HEIGHT mm [INCH]	CRIMP HEIGHT REFERENCE SETTING
0.35+0.35mm2	1.16+/-0.05 [.046+/- .002]	9.9

- RECOMMENDED SPARE PARTS
- REFER TO SUPPLIED INSTRUCTION SHEET FOR CLEANING, LUBRICATION AND STORAGE OF APPLICATOR.
- APPLY PART NUMBER 2-23419-6 LOCTITE TO THREADS OF ITEM 242.
- CRIMP HEIGHT REFERENCE SETTING WAS THE SETTING USED WHEN THE APPLICATOR WAS QUALIFIED AT THE FACTORY. ADJUSTMENT MAY BE NECESSARY WHEN RUNNING APPLICATOR IN THE FIELD.
- 5. UNLESS SPECIFIED OTHERWISE TORQUE VALUES SHALL BE USED PER DOCUMENT, 101-35000.
- THIS CRIMP PARAMETER IS PROVIDED TO MEET A CUSTOM AND UNIQUE CUSTOMER REQUIREMENT. IT HAS BEEN EVALUATED AND IS CONDITIONALLY SPECIFIED BY TE CONNECTIVITY. THIS CUSTOMIZED CRIMP PARAMETER IS NOT LISTED AS AN APPROVED APPLICATION WITHIN THE TERMINAL MANUFACTURER'S SPECIFICATIONS. **TE CONNECTIVITY EXPRESSLY DISCLAIMS ANY AND ALL WARRANTIES THAT THE PRODUCT WILL PERFORM SIMILARLY TO VALIDATED AND APPROVED APPLICATIONS, AS STATED WITHIN THE MANUFACTURER'S APPLICATION SPECIFICATIONS, INCLUDING BUT NOT LIMITED TO IMPLIED WARRANTIES OF MERCHANTABILITY OR FITNESS FOR PARTICULAR PURPOSE.** AS SUCH, IT IS HIGHLY RECOMMENDED THAT THE CUSTOMER PERFORM FURTHER DETAILED EVALUATION TO ASSESS PRODUCT PERFORMANCE IN THE SPECIFIC APPLICATION AND OBTAIN APPROVAL FROM TERMINAL MANUFACTURER FOR THIS CUSTOM REQUIREMENT.

***WARNING**
ON INSTALLATION, SET WIRE DISC TO CRIMP HEIGHT REFERENCE SETTING FOR LARGEST WIRE SIZE. CRIMP HEIGHT REFERENCE SETTINGS GREATER THAN THE VALUE SHOWN MAY CAUSE DAMAGE TO THE CRIMP TOOLING, REFER TO THE INSTRUCTION SHEET FOR PROPER SETUP AND ADJUSTMENTS.

ATLANTIC VERSION
Shown on sheets 1 of 4 & 2 of 4
(Pacific version shown on sheets 3 of 4 & 4 of 4)

LOC	DIST	REVISIONS			
		REV	DATE	BY	APPV
A	66	B	29JAN2015	JH	GB
		B1	28MAR2018	FL	JD

-	1	-	1	-	2119640-1	PUSH ROD, AIR FEED	250
-	1	-	1	-	1803259-1	BUSHING, FLANGED	249
-	1	-	1	-	2119641-1	FEED CAM, AIR FEED	248
-	1	1	1	1	2119082-4	CAM, SNAIL, INSULATION ADJUSTMENT	244
-	1	1	1	1	2079764-1	WASHER, WAVE SPRING, CREST-TO-CREST	243
-	1	1	1	1	2119083-1	RETAINER, INSULATION DIAL	242
-	1	1	1	1	7-18023-7	SCR, SKT HD CAP M3 X 4.0	241
-	-	1	-	1	2119580-1	MECHANICAL FEED ASSEMBLY	239
-	1	-	1	-	2063440-1	AIR FEED MODULE	238
-	2	-	2	-	21045-3	RING, RETAIN, EXTERN, 3/16 CRESCENT	172
-	REF	REF	REF	REF	994970-2	COUNTER, MAGNETIC	164
-	1	-	1	-	240638-1	SPRING, FEED FINGER	163
-	1	-	1	-	3-23627-7	PIN, RETAIN, GRVD, 3/16 X .854	137
-	1	-	1	-	2119799-1	HOLDER, FEED FINGER, AF	136
-	1	1	1	1	2844908-1	SCREW, LOCKING	99
-	1	1	1	1	2844907-1	POST, LOCKING	98
-	1	1	1	1	455888-5	SPACER, CRIMPER	82
-	1	1	1	1	1803607-1	DOCUMENTATION PACKAGE	71
-	1	1	1	1	2119791-9	DEPRESSOR, WIRE	70
-	1	1	1	1	2119740-1	TAG, IDENTIFICATION	67
-	2	2	2	2	2168078-1	SCREW, DRIVE, RH, RoHS, 2 x .188	66
-	1	1	1	1	2168083-2	SCR, SKT HD CAP, RoHS, M4 X 8.0	60
-	1	1	1	1	5-18022-5	SCR, HEX HD CAP, M4 X 6.0	59
-	1	1	1	1	1338685-1	PAWL, FEED	56
-	4	4	4	4	2168083-3	SCR, SKT HD CAP, RoHS, M4 X 12.0	54
-	2	2	2	2	2168083-3	SCR, SKT HD CAP, RoHS, M4 X 12.0	53
-	1	1	1	1	5018030-1	NUT, HEX, REG, RoHS, M3	52
-	1	1	1	1	811242-5	BUMPER, HOLD DOWN	51
-	1	1	1	1	690753-2	SPACER, TONKER	50
-	1	2	1	2	18023-9	SCR, SKT HD CAP M4 X 6.0	49
-	-	1	-	1	2119652-1	FEED CAM, PRE FEED	48
-	-	1	-	1	2119653-1	FEED CAM, POST FEED	47
-	1	1	1	1	1803583-9	APPLICATOR BASIC ASSEMBLY, SF	46
-	1	1	1	1	1803515-1	RAM ASSEMBLY, SF ATLANTIC	44
-	1	1	1	1	1803602-1	SCR, BHSC, RoHS (M8 X 25)	41
-	1	1	1	1	1752356-1	SUPPORT, TERMINAL	34
-	2	2	2	2	2079383-5	SCR, BHSC, RoHS (M4 X 20)	33
-	2	2	2	2	2-2844962-4	SPACER, CYLINDRICAL, STRIP GUIDE	30
-	1	1	1	1	2844992-1	ASSEMBLY, STRIP GUIDE	29
-	1	1	1	1	1320928-2	STRIP GUIDE	24
-	1	1	1	1	2168083-2	SCR, SKT HD CAP, RoHS, M4 X 8.0	21
-	2	2	2	2	1-18028-2	WASHER, FLAT, REG M4	20
-	1	1	1	1	2119533-1	STRIPPER, SIDE FEED	19
-	1	1	1	1	2119806-1	INSERT, SHEAR	13
-	1	1	1	1	3-22280-3	SPRING, COMPRESSION	12
-	1	1	1	1	1-356885-4	STOP, SHEAR	11
-	1	1	1	1	2119805-1	SHEAR HOLDER, FRONT	10
-	1	1	1	1	1803095-1	FLOATING SHEAR, FRONT	9
-	1	2	2	1	1-1803057-1	ANVIL, COMBINATION	8
-	1	1	1	1	1-240641-9	SPACER	7
-	-	-	-	-	-	-	6
-	1	1	1	1	2119757-9	DEPRESSOR, SHEAR	5
-	1	1	1	1	1-238011-0	BLOCK, CRIMPER SPACER	4
-	1	2	2	1	3-1633966-3	CRIMPER, INSULATION O	3
-	1	1	1	1	455888-3	SPACER, CRIMPER	2
-	1	2	2	1	1803179-4	CRIMPER, WIRE PREMIUM	1

DIMENSIONS:		TOLERANCES UNLESS OTHERWISE SPECIFIED:		APPLICATOR DATA	
mm	0 PLC ±	1 PLC ±	2 PLC ±	3 PLC ±	4 PLC ±
	ANGLES	FINISH			
MATERIAL					

OWN	CHK	APVD	DATE	NAME
L. GROSS	G. BAILEY	D. STOUGH	10AUG2014	G. BAILEY

SIZE	CAGE CODE	DRAWING NO	RESTRICTED TO
A1	00779	2151833	-

Customer Accessible Production Drawing SCALE 1:2 SHEET 1 of 4 REV C

LOC	DIST	REV	DESCRIPTION	DATE	OWN	APVD
A	66	-	SEE SHEET 1	-	-	-

FEED TYPE MECHANICAL

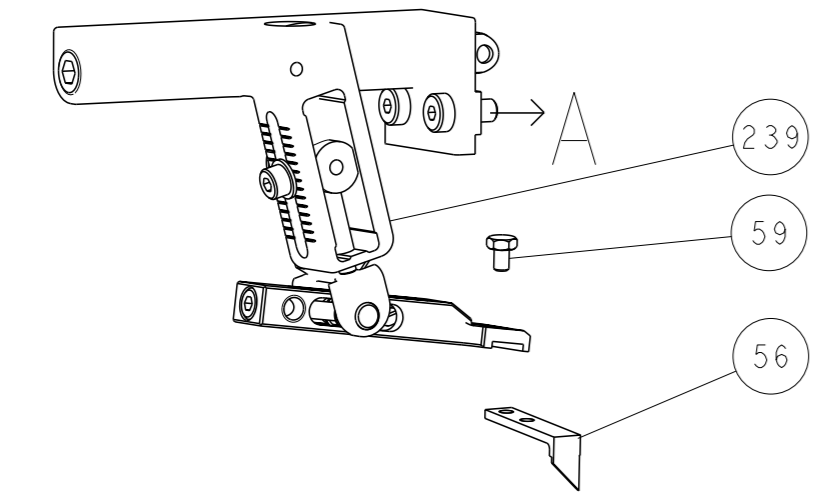

PNEUMATIC

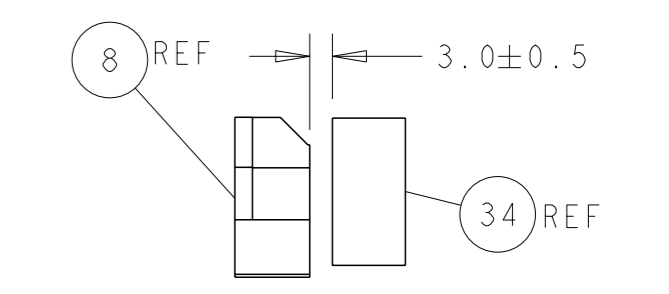
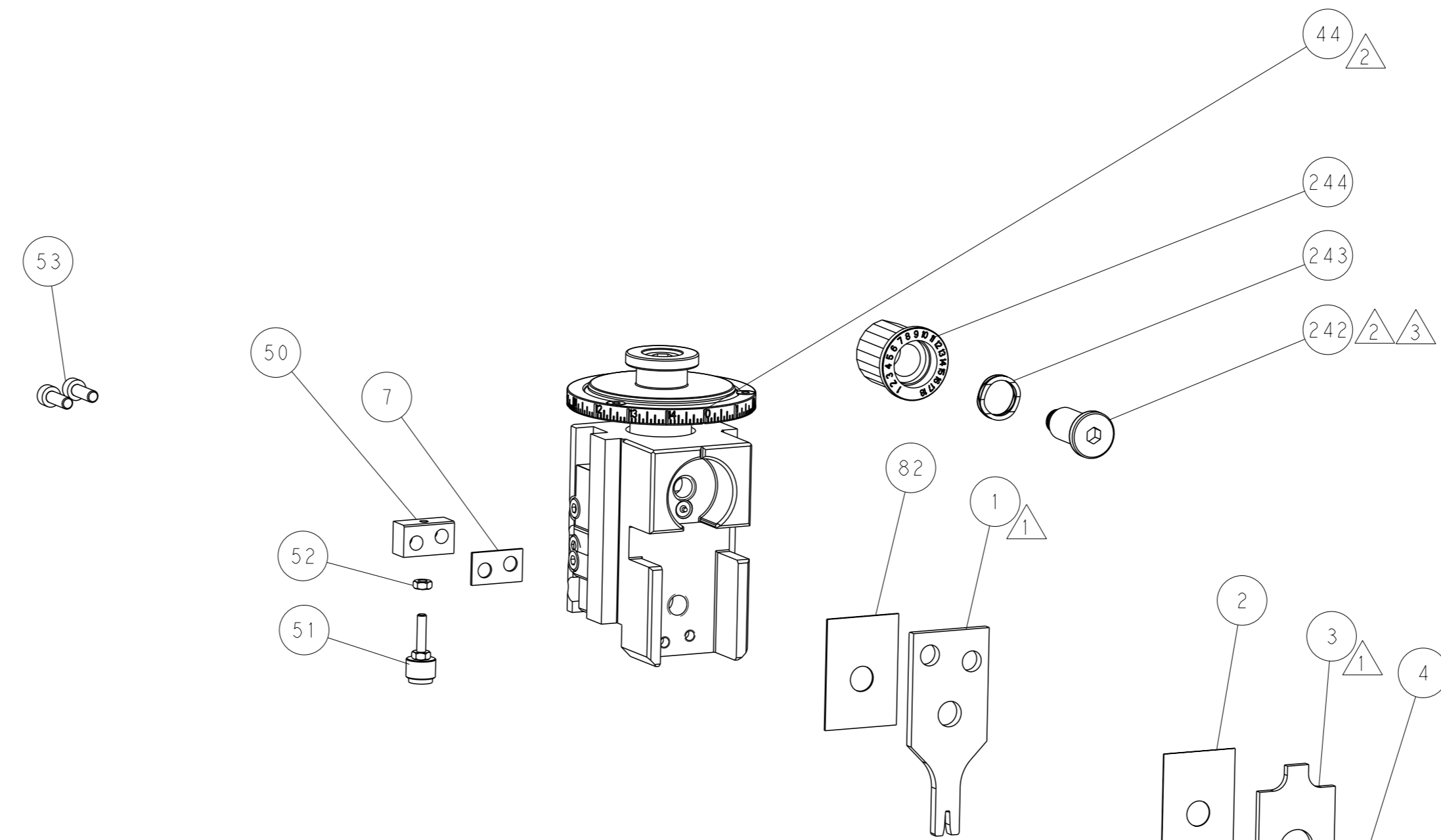
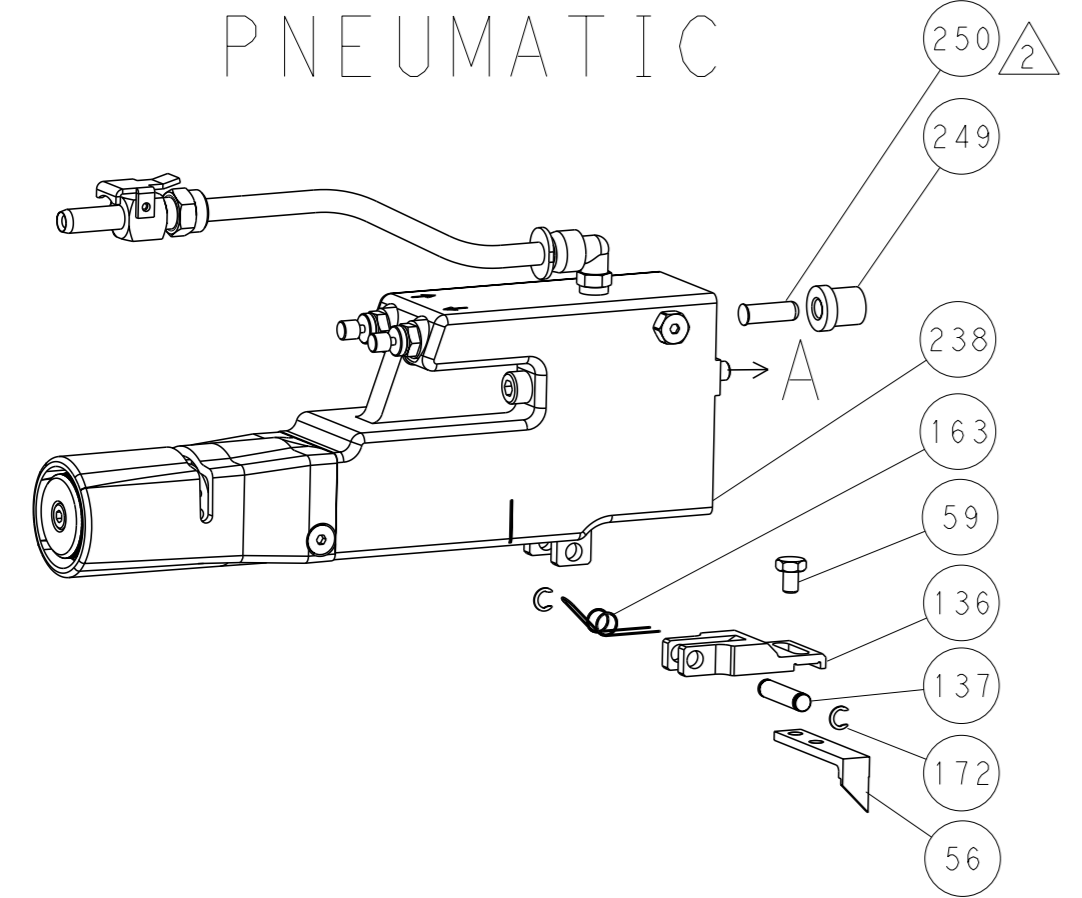

TERMINAL SUPPORT LOCATION

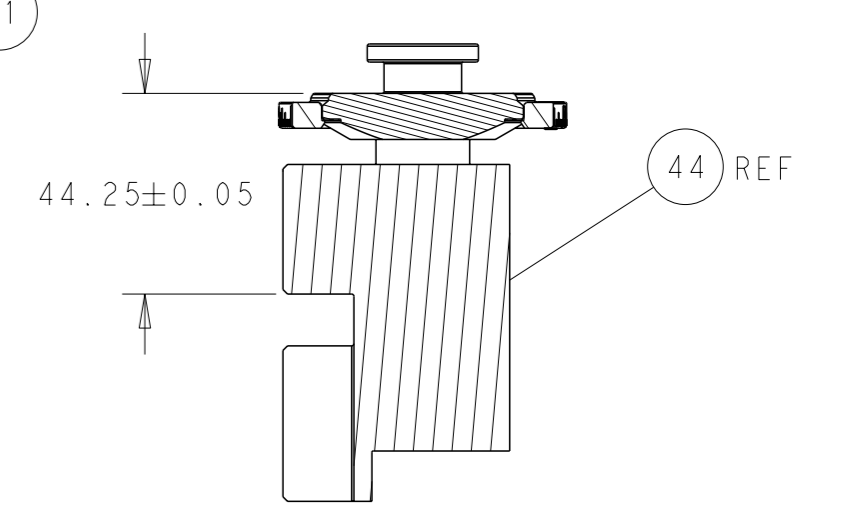

RAM SET-UP

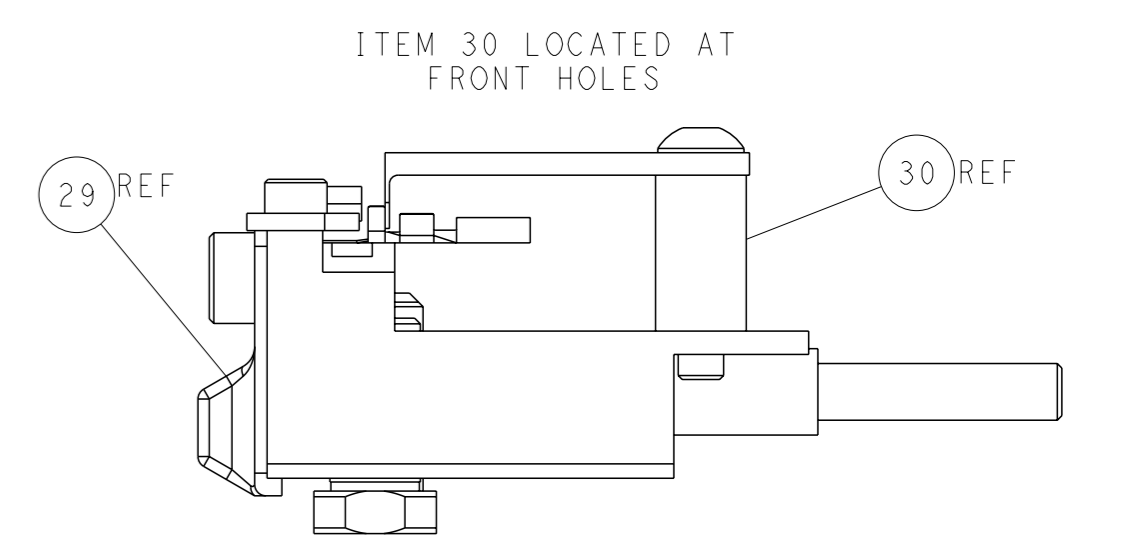
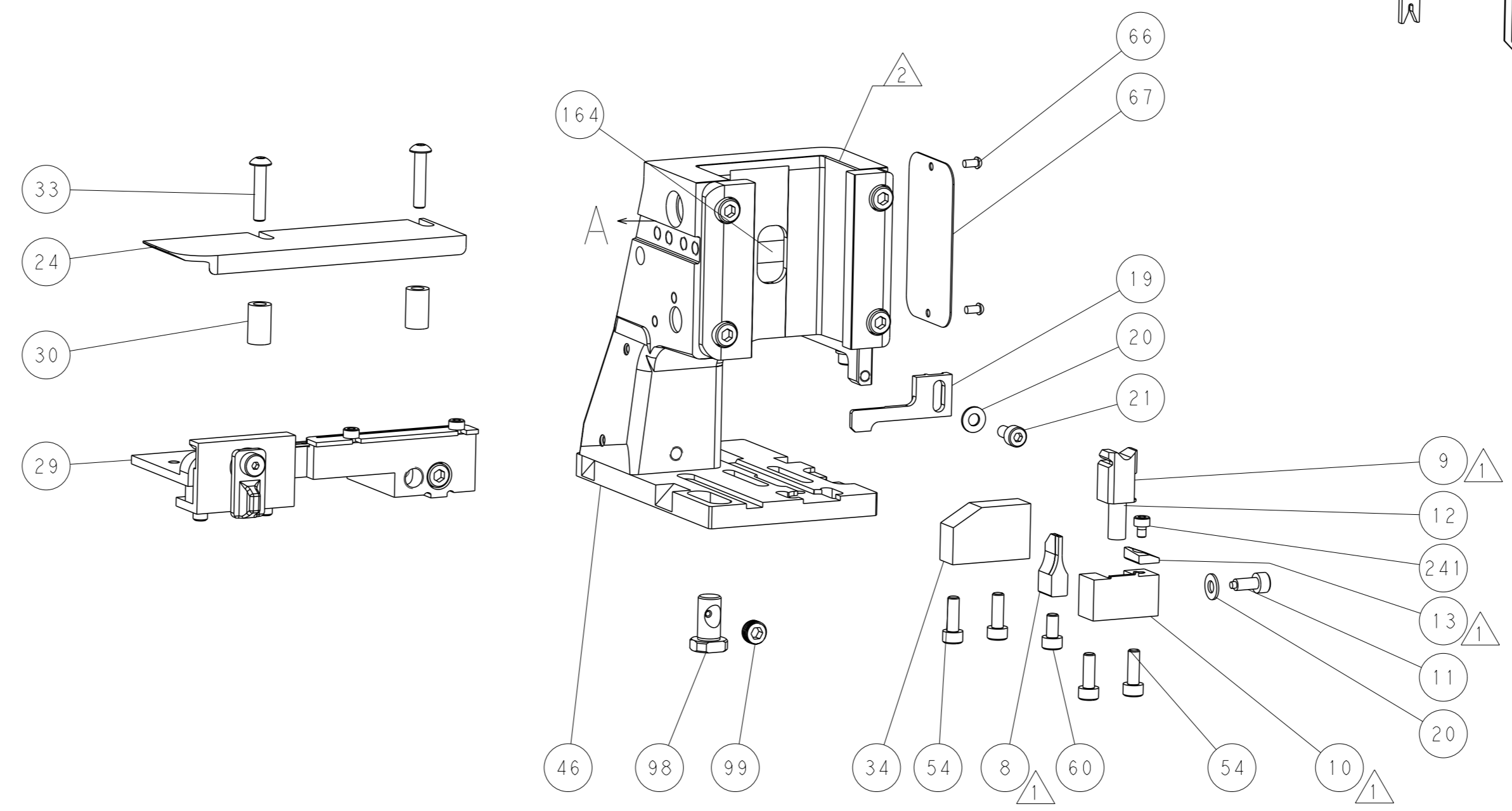

FEED TRACK POSITION GUIDE BY INSULATION BARREL

CAM POSITIONS

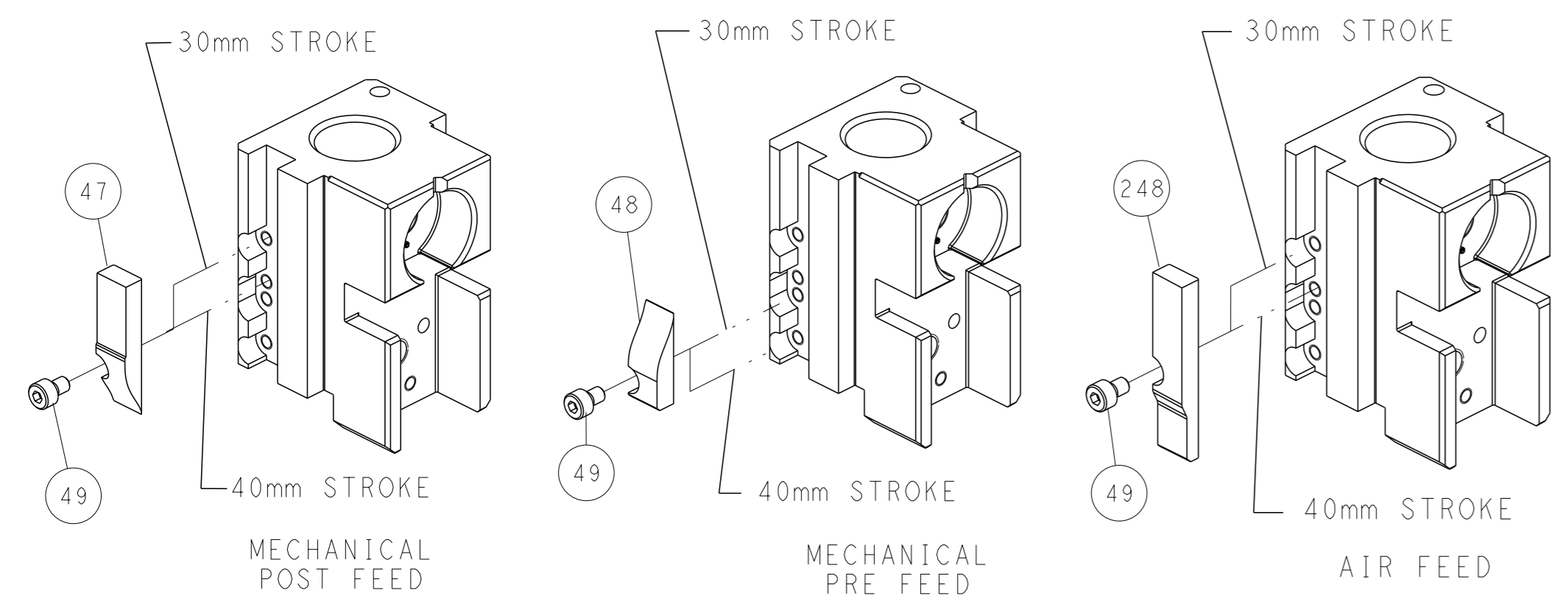

ATLANTIC VERSION
 Shown on sheets 1 of 4 & 2 of 4
 (Pacific version shown on sheets 3 of 4 & 4 of 4)

<small>THIS DRAWING IS A CONTROLLED DOCUMENT FOR TYCO ELECTRONICS CORPORATION. IT IS SUBJECT TO CHANGE AND THE CONTROL AND REVISIONS DISPOSITION SHOULD BE CONTACTED FOR THE LATEST REVISION.</small>		DWN: 10AUG2014 CHK: G. BAILEY APVD: D. STOUGH PRODUCT SPEC: 10AUG2014	NAME: Ocean Side Feed Applicator SIZE: A1 CAGE CODE: 00779 DRAWING NO: C=2151833	TE Connectivity Harrisburg, PA 17105-3608
DIMENSIONS: mm TOLERANCES UNLESS OTHERWISE SPECIFIED: 0 PLC ± 1 PLC ± 2 PLC ± 3 PLC ± 4 PLC ± ANGLES ± FINISH:	WEIGHT: - SCALE: 1:2 SHEET: 2 of 4 REV: C	Customer Accessible Production Drawing		

PART NUMBER	REVISION	DESCRIPTION	FEED TYPE
2-2151833-1	C	FINE CRIMP HEIGHT ADJUST	MECHANICAL
2-2151833-2	C	FINE CRIMP HEIGHT ADJUST	PNEUMATIC
7-2151833-7	A	CRIMP TOOLING KIT	-

PACIFIC VERSION TERMINATOR
INTERFACE ADAPTER

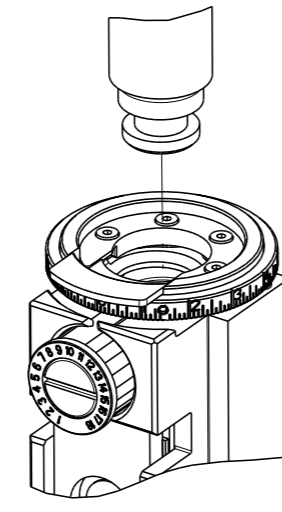

APPLICATOR DATA		
CRIMP	SIZE	TYPE
WIRE	1.60 mm [.063]	F
INSUL	1.60 mm [.063]	O
APPLICATOR INSTRUCTIONS 408-35042		

TERMINAL DATA: JST TERMINAL JST CRIMP SPECIFICATION			
TERMINAL NAME: TERMINAL FEMALE AIT 064 F.			
WIRE STRIP LENGTH	INSULATION DIAMETER RANGE		
4.00-4.50 mm [.157-.177 IN]	∅ 1.95mm MAX [.077 IN MAX]		
TERMINAL APPLICATION SPECIFICATION	JST Rev 1	-	-
TERMINALS APPLIED			
TE TERMINAL	JST TERMINAL	TE TERMINAL	JST TERMINAL
1832719-2	SAIT-A02T-M064	2113555-1	SAIT-A02GF-M064

TERMINAL DATA: JST TERMINAL JST CRIMP SPECIFICATION			
TERMINAL NAME: TERMINAL FEMALE AIT 064 F.			
WIRE STRIP LENGTH	INSULATION DIAMETER RANGE		
4.00-4.50 mm [.157-.177 IN]	∅ 1.95mm MAX [.077 IN MAX]		
TERMINAL APPLICATION SPECIFICATION		-	-
TERMINALS APPLIED			
TE TERMINAL	JST TERMINAL	TE TERMINAL	JST TERMINAL
1832719-2	SAIT-A02T-M064		

WIRE SIZE	CRIMP HEIGHT mm [INCH]	CRIMP HEIGHT REFERENCE SETTING
18 AWG OR 0.85mm2	1.20+/-0.05 [.047+/-0.002]	9.7
20 AWG OR 0.50mm2	1.05+/-0.05 [.041+/-0.002]	10.5

WIRE SIZE	CRIMP HEIGHT mm [INCH]	CRIMP HEIGHT REFERENCE SETTING
0.35+0.35mm2	1.16+/-0.05 [.046+/-0.002]	9.9

- 1 RECOMMENDED SPARE PARTS
- 2 REFER TO SUPPLIED INSTRUCTION SHEET FOR CLEANING, LUBRICATION AND STORAGE OF APPLICATOR.
- 3 APPLY PART NUMBER 2-23419-6 LOCTITE TO THREADS OF ITEM 242.
- 4 CRIMP HEIGHT REFERENCE SETTING WAS THE SETTING USED WHEN THE APPLICATOR WAS QUALIFIED AT THE FACTORY. ADJUSTMENT MAY BE NECESSARY WHEN RUNNING APPLICATOR IN THE FIELD.
- 5 UNLESS SPECIFIED OTHERWISE TORQUE VALUES SHALL BE USED PER DOCUMENT, 101-35000.
- 6 THIS CRIMP PARAMETER IS PROVIDED TO MEET A CUSTOM AND UNIQUE CUSTOMER REQUIREMENT. IT HAS BEEN EVALUATED AND IS CONDITIONALLY SPECIFIED BY TE CONNECTIVITY. THIS CUSTOMIZED CRIMP PARAMETER IS NOT LISTED AS AN APPROVED APPLICATION WITHIN THE TERMINAL MANUFACTURER'S SPECIFICATIONS. **TE CONNECTIVITY EXPRESSLY DISCLAIMS ANY AND ALL WARRANTIES THAT THE PRODUCT WILL PERFORM SIMILARLY TO VALIDATED AND APPROVED APPLICATIONS, AS STATED WITHIN THE MANUFACTURER'S APPLICATION SPECIFICATIONS, INCLUDING BUT NOT LIMITED TO IMPLIED WARRANTIES OF MERCHANTABILITY OR FITNESS FOR PARTICULAR PURPOSE.** AS SUCH, IT IS HIGHLY RECOMMENDED THAT THE CUSTOMER PERFORM FURTHER DETAILED EVALUATION TO ASSESS PRODUCT PERFORMANCE IN THE SPECIFIC APPLICATION AND OBTAIN APPROVAL FROM TERMINAL MANUFACTURER FOR THIS CUSTOM REQUIREMENT.

***WARNING**
ON INSTALLATION, SET WIRE DISC TO CRIMP HEIGHT REFERENCE SETTING FOR LARGEST WIRE SIZE. CRIMP HEIGHT REFERENCE SETTINGS GREATER THAN THE VALUE SHOWN MAY CAUSE DAMAGE TO THE CRIMP TOOLING, REFER TO THE INSTRUCTION SHEET FOR PROPER SETUP AND ADJUSTMENTS.

PACIFIC VERSION
Shown on sheets 3 of 4 & 4 of 4
(Atlantic version shown on sheets 1 of 4 & 2 of 4)

LOC	DIST	REVISIONS			
P	LYR	DESCRIPTION	DATE	OWN	APVD
A	66	SEE SHEET 1	-	-	-

-	1	-	2119640-1	PUSH ROD, AIR FEED	250
-	1	-	1803259-1	BUSHING, FLANGED	249
-	1	1	2119082-4	CAM, SNAIL, INSULATION ADJUSTMENT	244
-	1	1	2079764-1	WASHER, WAVE SPRING, CREST-TO-CREST	243
-	1	1	2119083-1	RETAINER, INSULATION DIAL	242
-	1	1	7-18023-7	SCR, SKT HD CAP M3 X 4.0	241
-	-	1	2119580-1	MECHANICAL FEED ASSEMBLY	239
-	1	-	2063440-1	AIR FEED MODULE	238
-	2	-	21045-3	RING, RETAIN, EXTERN, 3/16 CRESCENT	172
-	REF	REF	994970-2	COUNTER, MAGNETIC	164
-	1	-	240638-1	SPRING, FEED FINGER	163
-	1	-	2119641-2	FEED CAM, AIR FEED	151
-	1	1	2168083-8	SCR, SKT HD CAP, RoHS, M4 X 16	144
-	4	4	2168083-9	SCR, SKT HD CAP, RoHS, M4 X 20	143
-	-	1	2119653-2	FEED CAM, POST FEED	142
-	1	1	1-1803583-0	APPLICATOR BASIC ASSEMBLY, SF	141
-	1	1	1803516-1	RAM ASSEMBLY, SF PACIFIC	140
-	1	-	3-23627-7	PIN, RETAIN, GRVD, 3/16 X .854	137
-	1	-	2119799-1	HOLDER, FEED FINGER, AF	136
-	1	1	2844908-1	SCREW, LOCKING	99
-	1	1	2844907-1	POST, LOCKING	98
-	1	1	455888-5	SPACER, CRIMPER	82
-	1	1	1803607-1	DOCUMENTATION PACKAGE	71
-	1	1	2119791-9	DEPRESSOR, WIRE	70
-	1	1	2119740-1	TAG, IDENTIFICATION	67
-	2	2	2168078-1	SCREW, DRIVE, RH, RoHS, 2 x .188	66
-	1	1	5-18022-5	SCR, HEX HD CAP, M4 X 6.0	59
-	1	1	1338685-1	PAWL, FEED	56
-	2	2	2168083-3	SCR, SKT HD CAP, RoHS, M4 X 12.0	53
-	1	1	5018030-1	NUT, HEX, REG, RoHS, M3	52
-	1	1	811242-5	BUMPER, HOLD DOWN	51
-	1	1	690753-2	SPACER, TONKER	50
-	1	2	18023-9	SCR, SKT HD CAP M4 X 6.0	49
-	-	1	2119652-1	FEED CAM, PRE FEED	48
-	1	1	1803602-1	SCR, BHSC, RoHS (M8 X 25)	41
-	1	1	1752356-1	SUPPORT, TERMINAL	34
-	2	2	2079383-5	SCR, BHSC, RoHS (M4 X 20)	33
-	2	2	2-2844962-4	SPACER, CYLINDRICAL, STRIP GUIDE	30
-	1	1	2844992-1	ASSEMBLY, STRIP GUIDE	29
-	1	1	1320928-2	STRIP GUIDE	24
-	1	1	2168083-2	SCR, SKT HD CAP, RoHS, M4 X 8.0	21
-	2	2	1-18028-2	WASHER, FLAT, REG M4	20
-	1	1	2119533-1	STRIPPER, SIDE FEED	19
-	1	1	2119806-1	INSERT, SHEAR	13
-	1	1	3-22280-3	SPRING, COMPRESSION	12
-	1	1	1-356885-4	STOP, SHEAR	11
-	1	1	2119805-1	SHEAR HOLDER, FRONT	10
-	1	1	1803095-1	FLOATING SHEAR, FRONT	9
-	1	1	3-1803057-1	ANVIL, COMBINATION	8
-	1	1	1-240641-9	SPACER	7
-	-	-	-	-	6
-	1	1	2119757-9	DEPRESSOR, SHEAR	5
-	1	1	1-238011-0	BLOCK, CRIMPER SPACER	4
-	1	1	3-1633966-3	CRIMPER, INSULATION O	3
-	1	1	455888-3	SPACER, CRIMPER	2
-	1	1	1803179-4	CRIMPER, WIRE PREMIUM	1

DIMENSIONS:		TOLERANCES UNLESS OTHERWISE SPECIFIED:		APPROVED BY:		DATE:	
mm	0 PLC ±	1 PLC ±	2 PLC ±	3 PLC ±	4 PLC ±	ANGLES ±	FINISH
MATERIAL:		FINISH:		WEIGHT:		SCALE:	
Customer Accessible Production Drawing		SCALE: 1:2		SHEET 3 of 4		REV C	

LOC	DIST	REVISIONS			
		REV	DATE	BY	APPV
A	66	-	SEE SHEET 1	-	-

FEED TYPE MECHANICAL

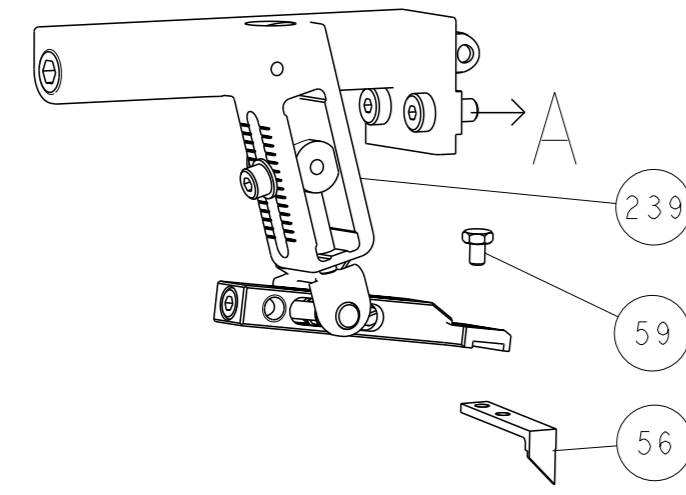

PNEUMATIC

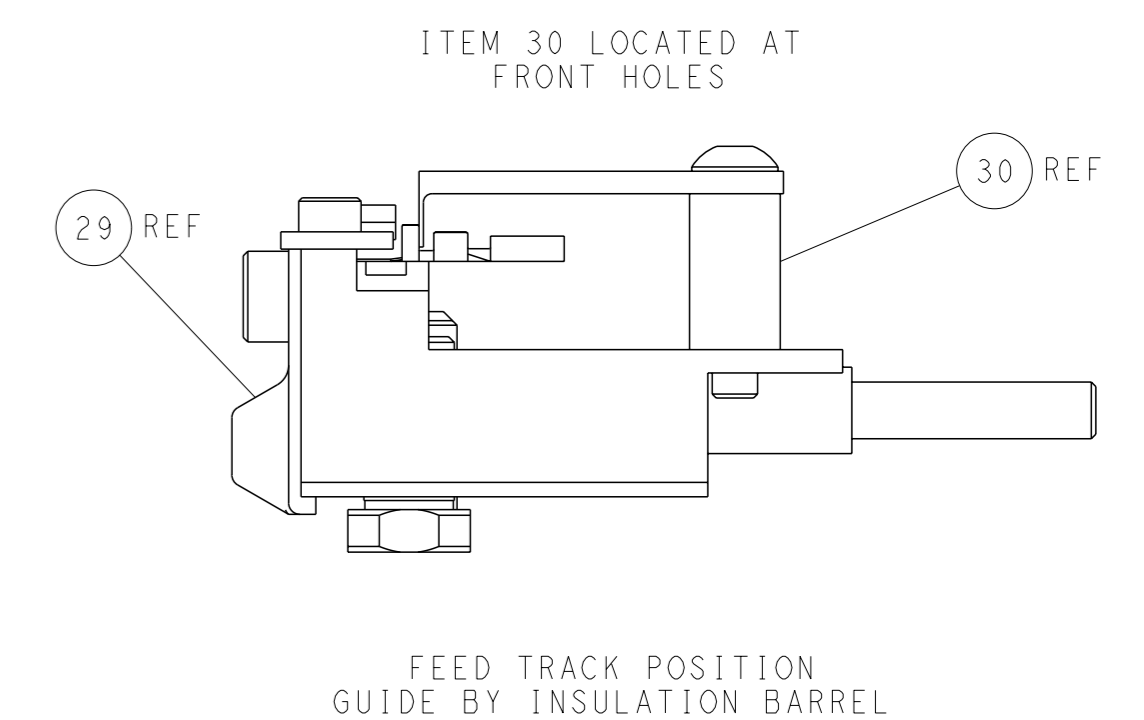
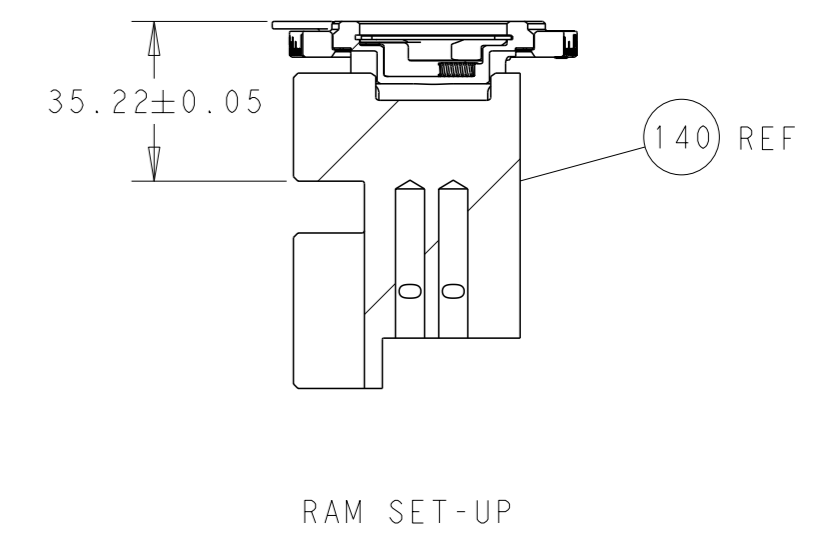
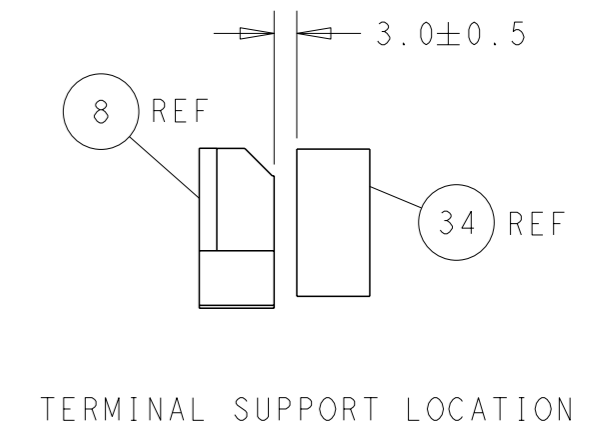
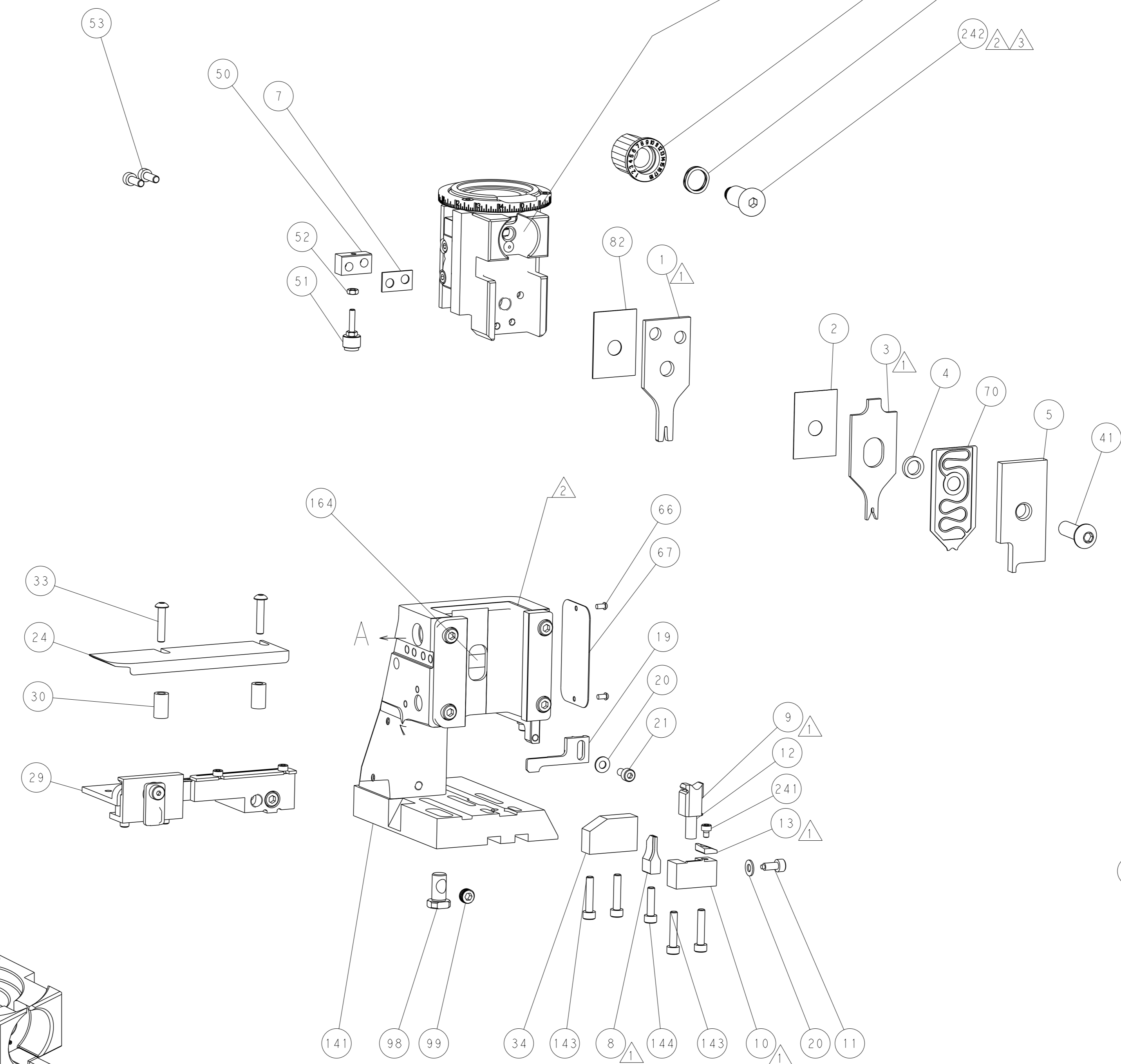
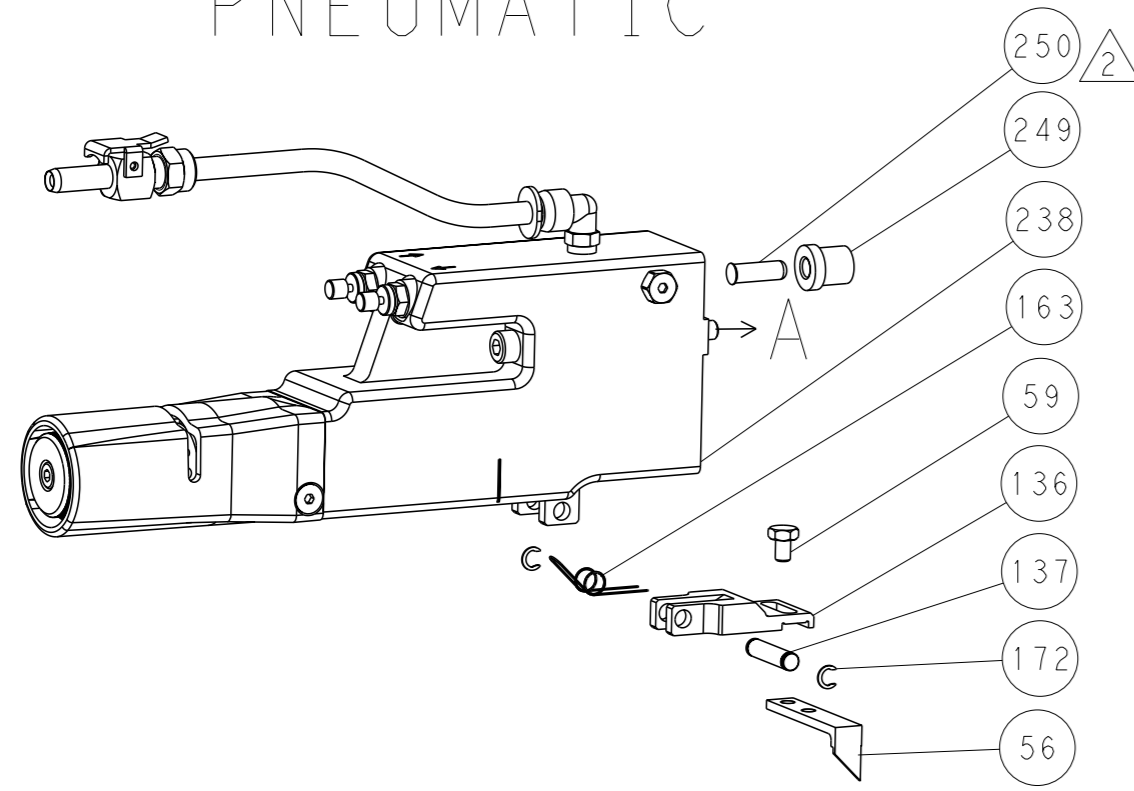

CAM POSITIONS

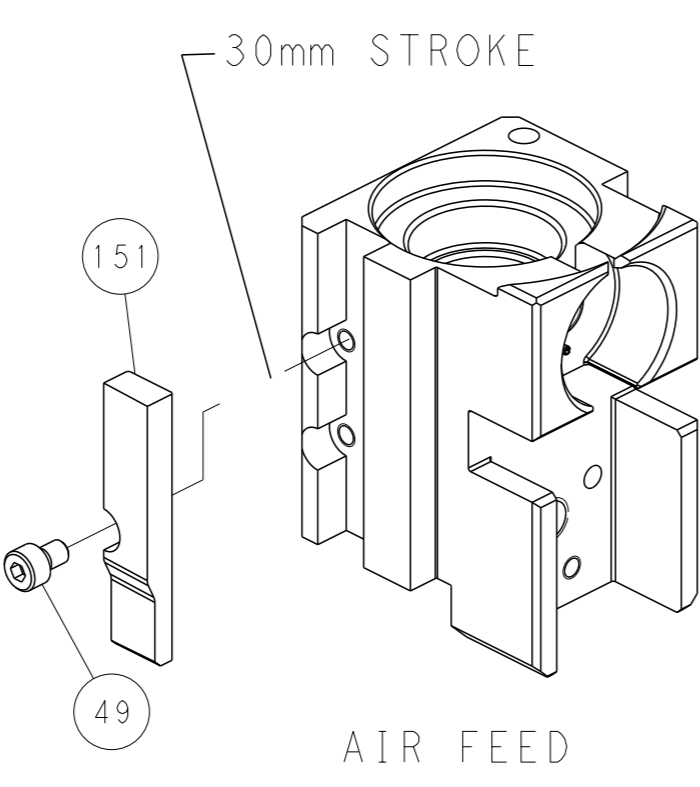
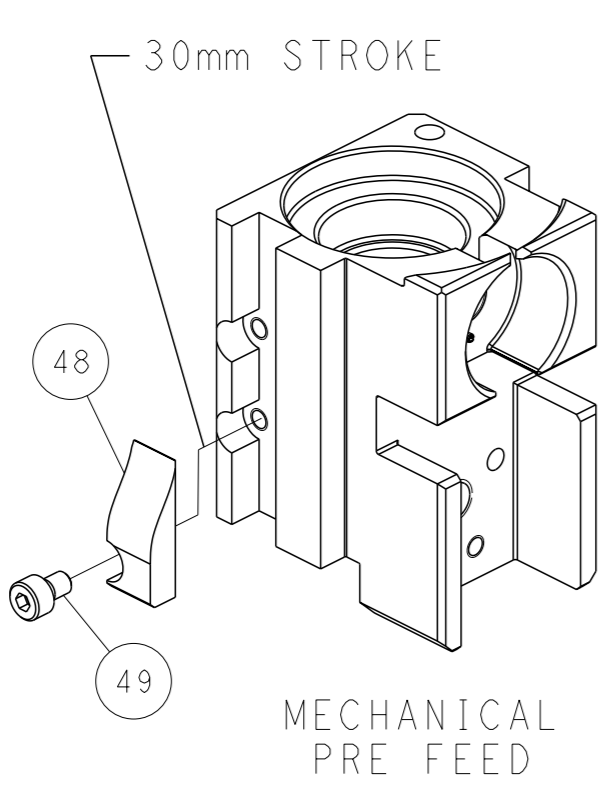
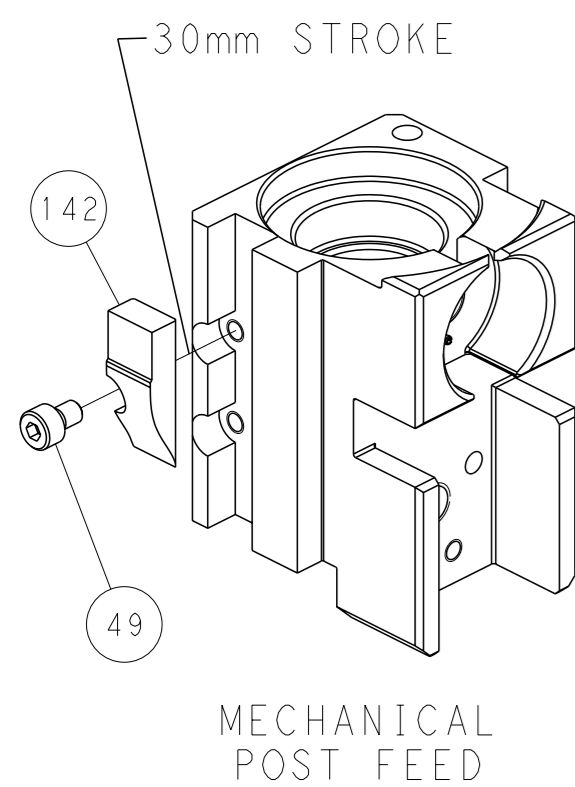

PACIFIC VERSION
 Shown on sheets 3 of 4 & 4 of 4
 (Atlantic version shown on sheets 1 of 4 & 2 of 4)

<small>THIS DRAWING IS A CONTROLLED DOCUMENT FOR TYCO ELECTRONICS CORPORATION. IT IS SUBJECT TO CHANGE AND THE CONTROLLING ENGINEERING ORGANIZATION SHOULD BE CONTACTED FOR THE LATEST REVISION.</small>		DWN: L.GROSS 10AUG2014 CHK: G.BAILEY 10AUG2014 APVD: D.STOUGH 10AUG2014	NAME: TE Connectivity Harrisburg, PA 17105-3608
DIMENSIONS: mm TOLERANCES UNLESS OTHERWISE SPECIFIED: 0 PLC ± 1 PLC ± 2 PLC ± 3 PLC ± 4 PLC ± ANGLES FINISH ±	APPLICATION SPEC: - WEIGHT: - SCALE: 1:2	SIZE: A1 CAGE CODE: 00779 DRAWING NO: C=2151833	RESTRICTED TO: - SHEET: 4 of 4 REV: C