

## Introduction

A table mounting clamp for parallel action hand crimp tools. This tool can only be used for the hand crimp tools shown on this document.

## Mounting Procedure (Figure 1)

1. Attach the *Table Mounting Block* to the tool body with the *Fastening Knob* through the oval slot in the bottom of the tool head.
2. Slide the *Table Clamp* through the bottom ledge of the *Table Mounting Block* and adjust the *Table Clamp* to fit tightly.

NOTE: Maximum table/bench thickness = 50.00 mm [1.97"]

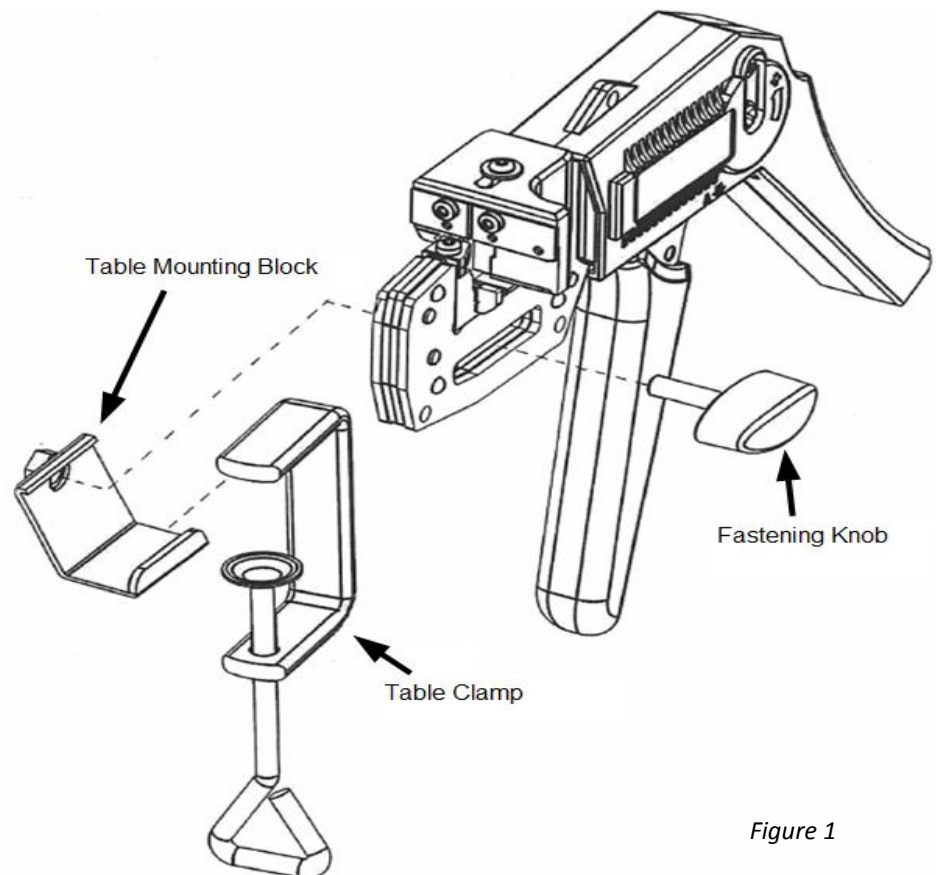

Figure 1