

REVISIONS					
P	LTR	DESCRIPTION	DATE	DWN	APVD
G		REVISED PER ECR-19-019812	02JAN2020	SR	BJ

SPECIFICATIONS:

MATERIAL

BASE, PPS, UL94V-0, BLACK
 COVER, PPS, UL94V-0, BLACK
 ACTUATOR, PA6T, UL94V-0, WHITE
 FIXED CONTACT/TERMINAL, CU ALLOY-GOLD FLASH OVER NICKEL
 MOVING CONTACT, CU ALLOY, PLATE-GOLD FLASH/NICKEL
 TAPE SEAL-POLYIMIDE FILM, AMBER, SEE P/N TABLE FOR OPTIONS

ELECTRICAL

MAX CONTACT RATING SWITCHING, 100mA @ 5 VDC (AMPERE MAX)
 25mA @ 24 VDC (VOLTAGE MAX)

MIN CONTACT RATING SWITCHING, 0.1mA (1mV)
 MAX CONTACT NON-SWITCHING, 1AMP @ 5 VDC
 INITIAL CONTACT RESISTANCE, 50 MILLIOHMS MAX.
 CONTACT RESISTANCE (AFTER ENVIRONMENTAL TEST), 100 MILLIOHMS
 CONTACT RESISTANCE (AFTER GAS TEST), 300 MILLIOHMS
 INSULATION RESISTANCE, 1,000 MEGOHMS MIN. @ 100 VDC
 DIELECTRIC STRENGTH, 300 VAC FOR 1 MINUTE.
 LIFE EXPECTANCY, 1,000 CYCLES

MECHANICAL

OPERATING FORCE, LESS THAN 800 GRAMS
 CONTACT PRESSURE, 280,000 PSI

ENVIRONMENTAL

OPERATING TEMPERATURE, -30 TO +85 DEGREES C
 STORAGE TEMPERATURE, -30 TO +85 DEGREES C
 CLEANING, AQUEOUS OR SOLVENT
 SOLDER HEAT RESISTANCE, PER 109-201, COND B, SWITCH "OFF".
 SOLDERABILITY PER IPC/ECA J-STD-002D, TEST S1 LEAD-FREE SOLDER - SURFACE MOUNT PROCESS SIMULATION TEST.

1 SWITCHES TO BE RECEIVED IN THE "OFF" POSITION AND PACKAGED IN CLEAR TUBES TO ACCOMMODATE AUTO-INSERTION OR PACKAGED ON TAPE AND REEL

2 TOP SURFACE TO BE CLEARLY MARKED AS SHOWN

3 SWITCHES TO BE BLACK WITH WHITE ACTUATORS AND MARKINGS.

4 ALL MATERIALS AND FINISHES SHALL COMPLY WITH EU DIRECTIVE 2002/95/EC OF 27JAN2003 (ROHS)

5 TAPE AND REEL PACKAGING PER EIA 481.

6 PACKAGING REEL DIMENSIONS (PLEASE REFERENCE SHEET 2)
 FOR 1977208-1,-3, DIM: 24.5
 FOR 1977208-2,-4, DIM: 44.4

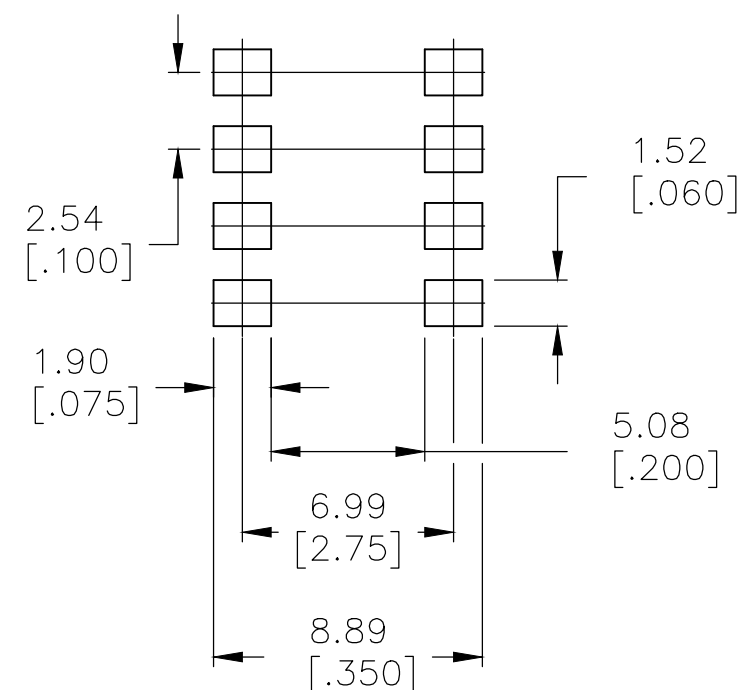
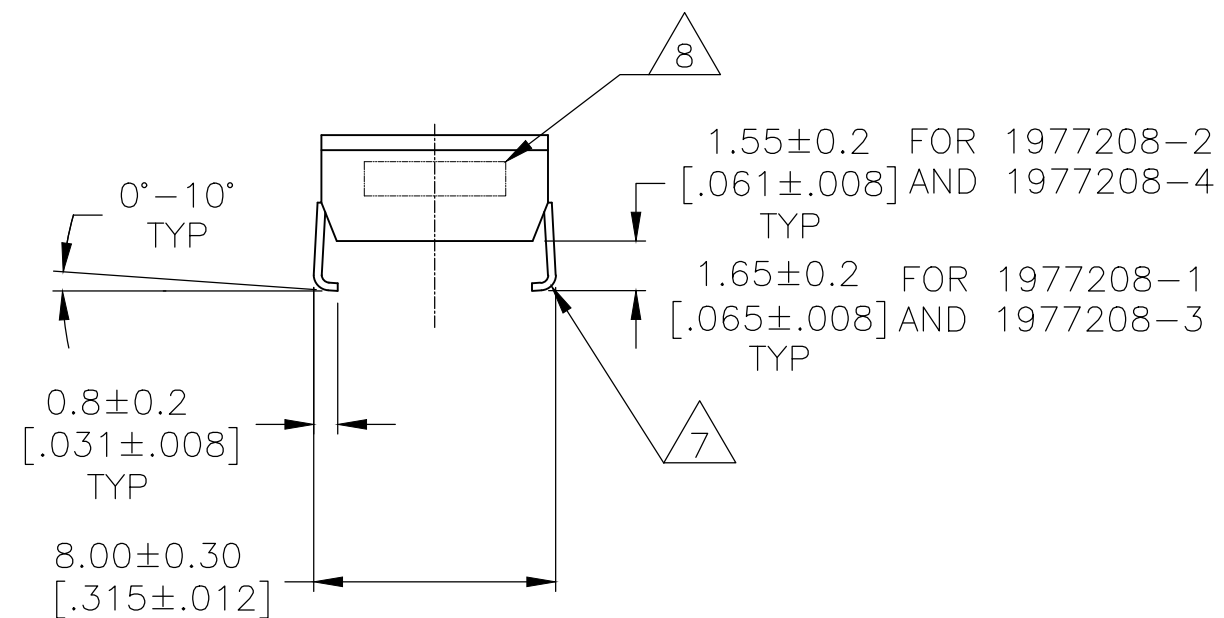
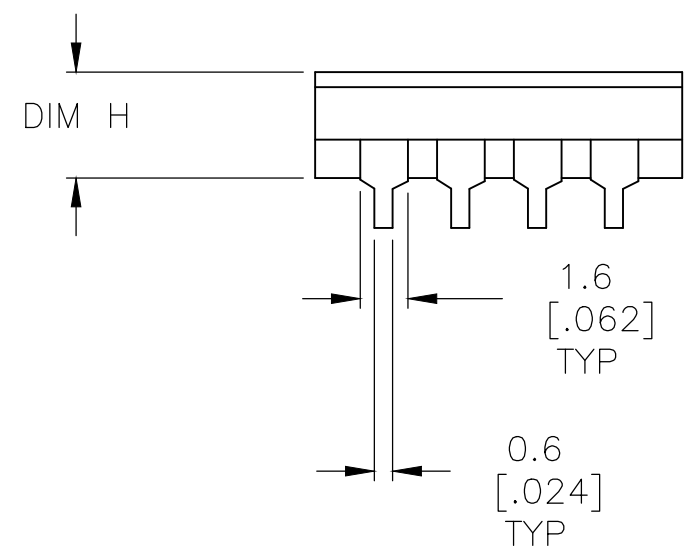
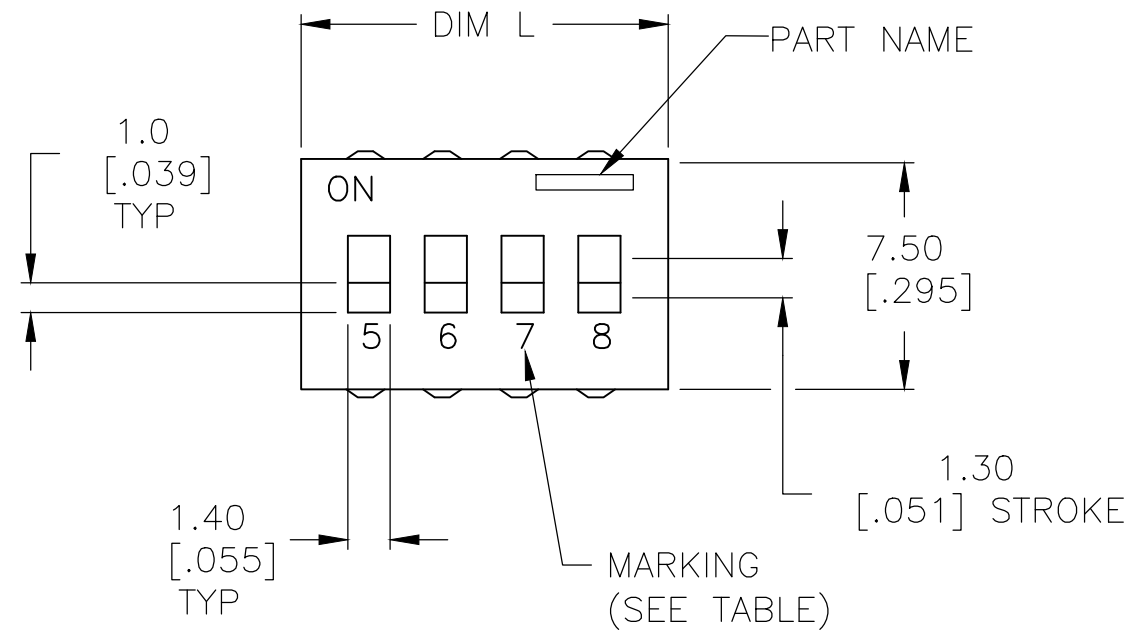

RECOMMENDED PAD LAYOUT

CONTACT PLATING DETAIL

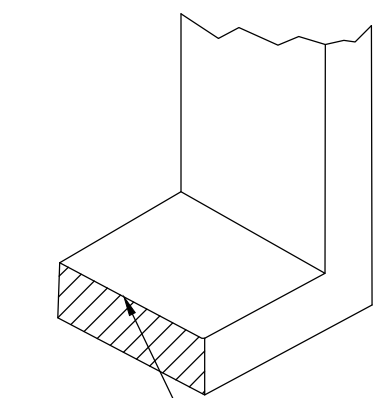

SHEAR EDGE NOT PLATED. ALL REMAINING SURFACES ARE SUPPLIED WITH GOLD-FLASH OVER NICKEL PLATING

1,2,3,4,5,6,7,8,1,2,3,4	T&R	NO	3.50 (.138)	32.50 (1.280)	12	ADF12SATRO4900	1977208-4
5,6,7,8	T&R	NO		12.1 (.478)	4	ADF04SATRO4900	1977208-3
1,2,3,4,5,6,7,8,1,2,3,4	T&R	YES	3.50 (.138)	32.50 (1.280)	12	ADF12SATTRO4900	1977208-2
5,6,7,8	T&R	YES		12.1 (.478)	4	ADF04SATTRO4900	1977208-1
MARKING	PKG.	TAPE SEAL	DIM H	DIM L	POLE	OLD T&B P/N	P/N

THIS DRAWING IS A CONTROLLED DOCUMENT.		DWN M.BINNER 30AUG07	TE Connectivity	
DIMENSIONS: mm [INCHES]		CHK M.SARVER		
TOLERANCES UNLESS OTHERWISE SPECIFIED:		APVD M.SARVER	NAME -	
0 PLC ± -	1 PLC ± -	PRODUCT SPEC -	DIP SWITCH, ADF-SMT SERIES, SPECIAL	
2 PLC ± 0.30[.012]	3 PLC ± -	APPLICATION SPEC -	SIZE A2	CAGE CODE -
4 PLC ± -	ANGLES ± -	WEIGHT -	DRAWING NO C=1977208	RESTRICTED TO -
MATERIAL -	FINISH -	CUSTOMER DRAWING	SCALE 4:1	SHEET 1 of 3
			REV G	

THIS DRAWING IS UNPUBLISHED. RELEASED FOR PUBLICATION . 1825059 1825059
 © COPYRIGHT 1825059y - ALL RIGHTS RESERVED.

REVISIONS				
P	LTR	DESCRIPTION	DATE	APVD
-	-	SEE SHEET 1	-	-

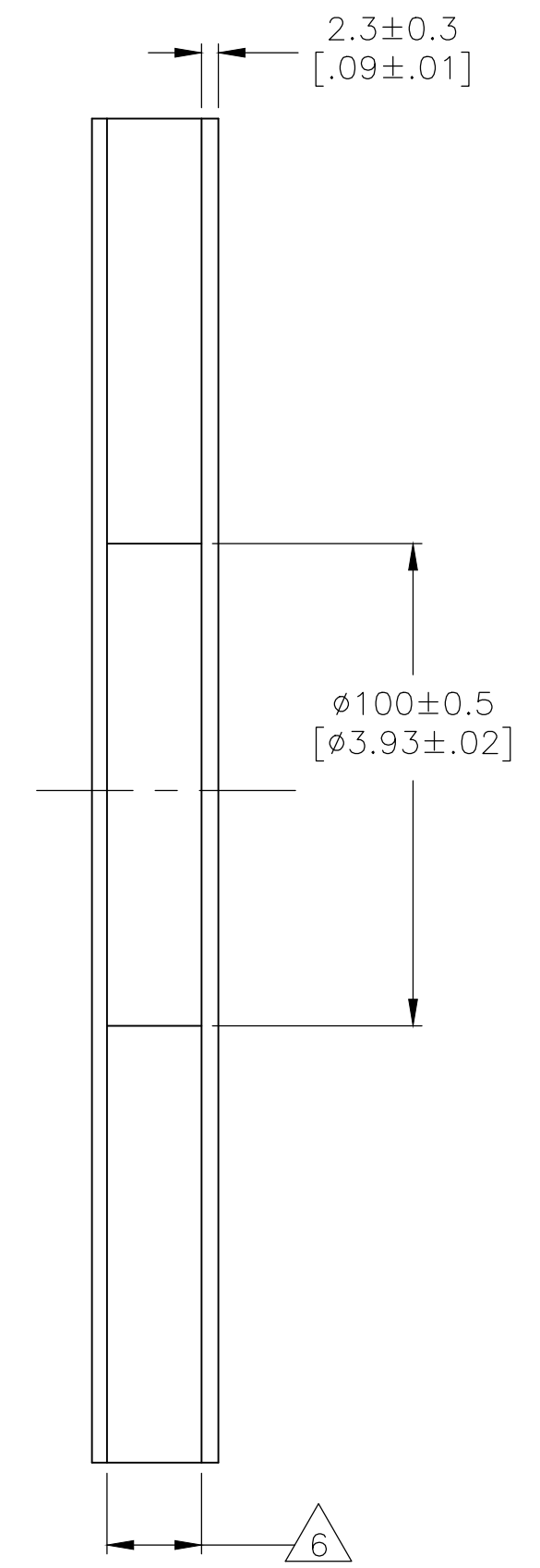
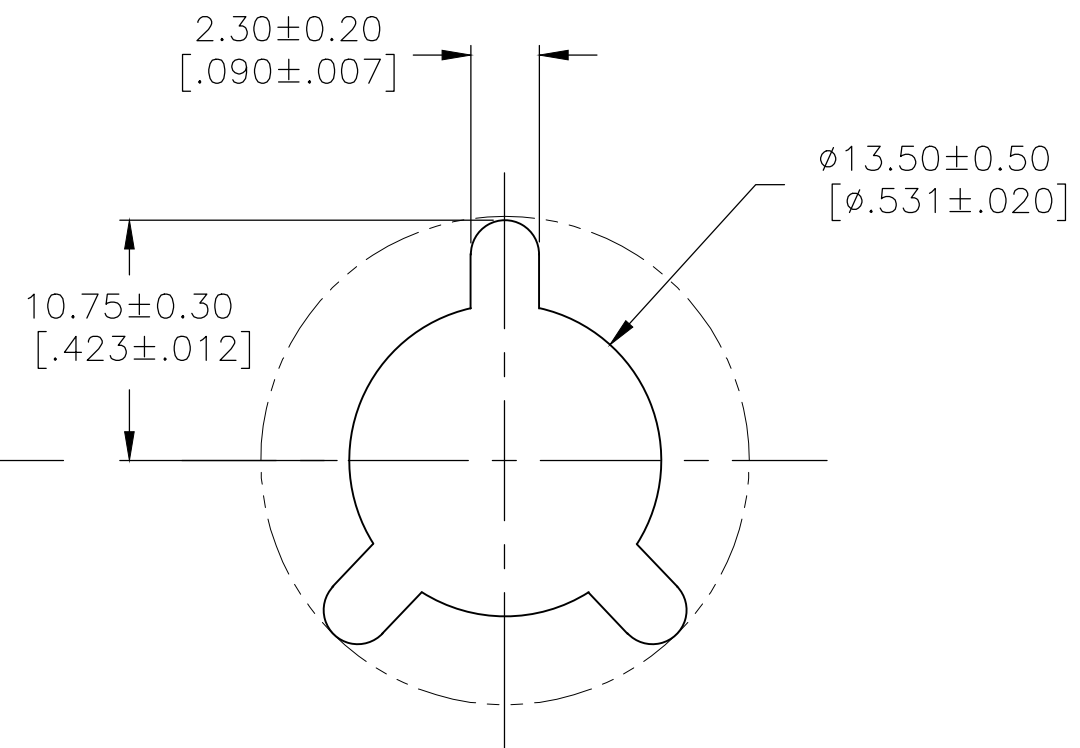
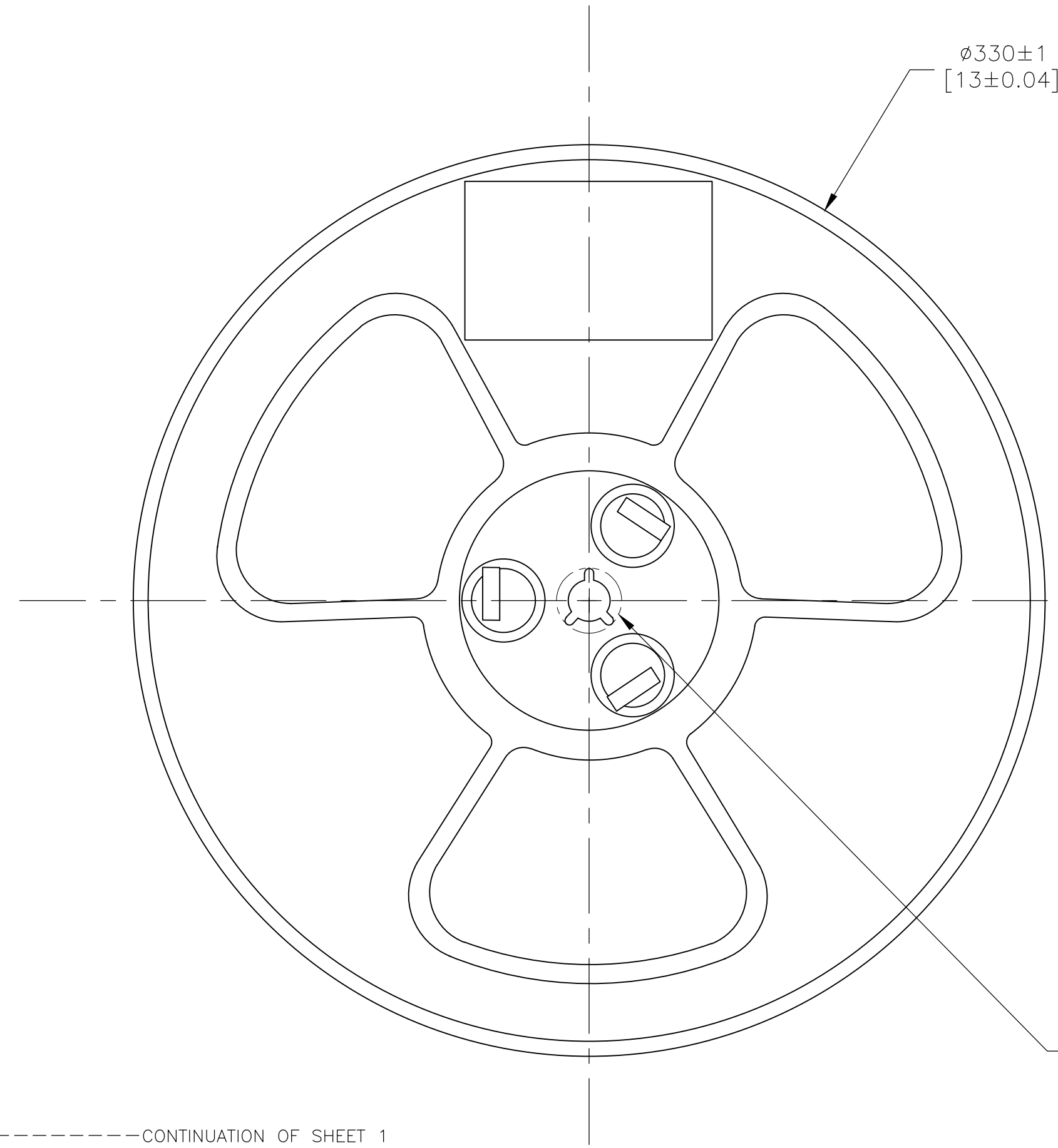

DETAIL A

-----CONTINUATION OF SHEET 1

7 SEE PLATING DETAIL FOR DEFINITION OF CONTACT PLATING SURFACES

8 LOT CODE MARKING

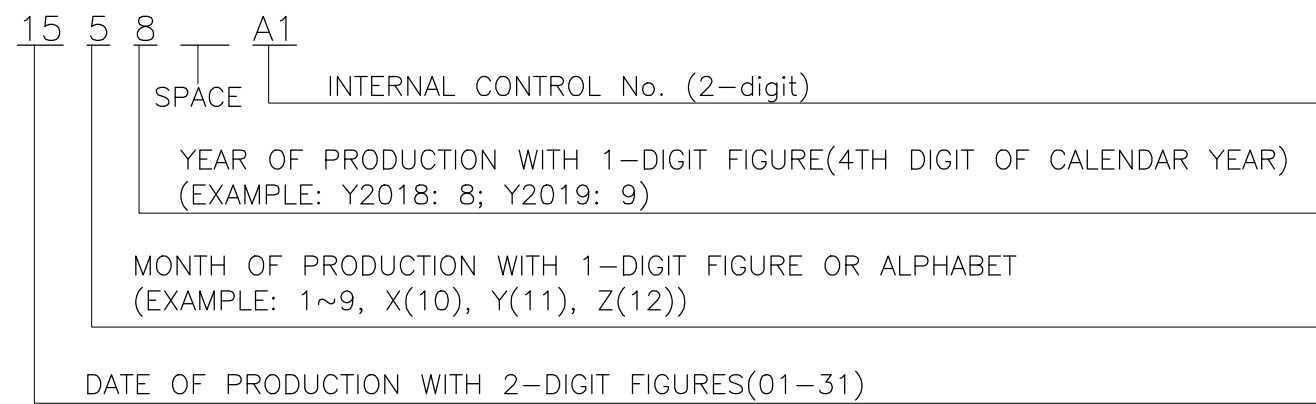

9. STICK A BAR CODE LABEL OF 40mm x 83mm TO EACH REEL.

THIS DRAWING IS A CONTROLLED DOCUMENT.		DWN M.BINNER 30AUG07		
DIMENSIONS: mm [INCHES]		CHK M.SARVER		
TOLERANCES UNLESS OTHERWISE SPECIFIED:		APVD M.SARVER	NAME	
0 PLC ± -		PRODUCT SPEC	DIP SWITCH, ADF-SMT SERIES, SPECIAL	
1 PLC ± -		APPLICATION SPEC	SIZE A2	CAGE CODE -
2 PLC ± 0.30[.012]		WEIGHT -	DRAWING NO. C=1977208	RESTRICTED TO -
3 PLC ± -		CUSTOMER DRAWING	SCALE 4:1	SHEET 2 of 3
4 PLC ± -			REV G	
ANGLES ± -				
FINISH -				

1977208

REVISIONS				
P	LTR	DESCRIPTION	DATE	APVD
-	-	SEE SHEET 1	-	-

BAR CODE LABEL DETAILS

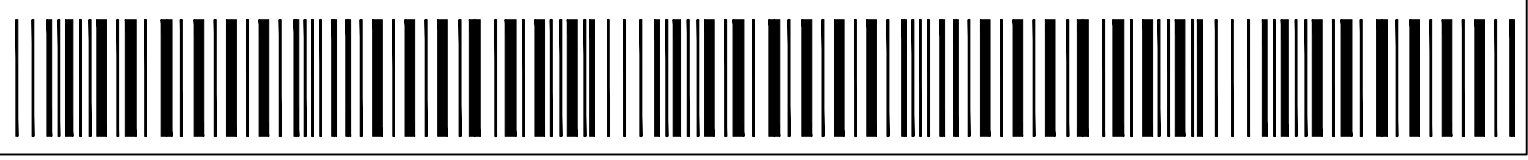
TE Part Number: 
1977208-3

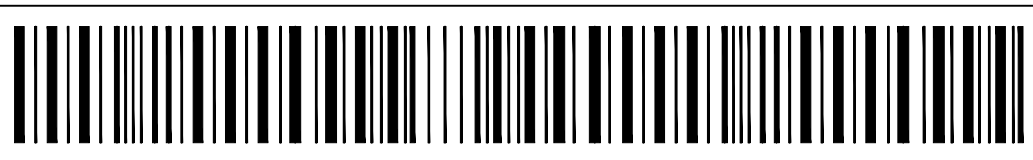
Part Description: 
ADF04SATR04900=4POS DIP

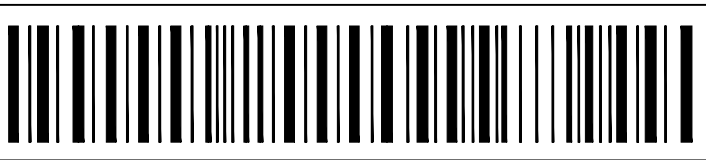
TE Connectivity: 

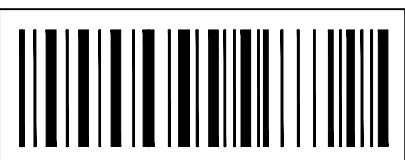
Qty: 
130

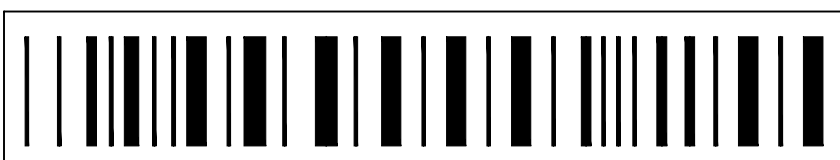
Date Code: 
1948

40 mm

83 mm

1977208

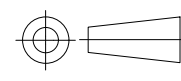
THIS DRAWING IS A CONTROLLED DOCUMENT.		DWN M.BINNER	30AUG07	TE TE Connectivity	
DIMENSIONS: mm [INCHES]		CHK M.SARVER	APVD M.SARVER		
		TOLERANCES UNLESS OTHERWISE SPECIFIED:		NAME -	
		0 PLC ± - 1 PLC ± - 2 PLC ± 0.30[.012] 3 PLC ± - 4 PLC ± - ANGLES ± -		PRODUCT SPEC -	
MATERIAL -	FINISH -	WEIGHT -	SCALE A2	CAGE CODE -	DRAWING NO C=1977208
CUSTOMER DRAWING			RESTRICTED TO -	SHEET 3 of 3	REV G