

## TS5MP646 4 Data Lane 2:1 MIPI Switch (10-Channel, 2:1 Analog Switch)

### 1 Features

- Supply Range of 1.65 V to 5.5 V
- 10-Channel 2:1 Switch
- Powered-Off Protection: I/Os Hi-Z when  $V_{DD} = 0$  V
- Low  $R_{ON}$  of 4.2- $\Omega$  Typical
- Bandwidth of 3 GHz
- Ultra Low Crosstalk of -40 dB
- Low Power Disable Mode
- 1.8-V Compatible Logic Inputs
- ESD Protection Exceeds JESD 22
  - 2000-V Human Body Model (HBM)

### 2 Applications

- Mobile Phones
- Tablet
- PC/Notebook
- Virtual and Augmented Reality
- Drones
- Camera-based carcode scanner
- Medical
- IP Netcam

### 3 Description

The TS5MP646 is a four data lane MIPI switch. This device is an optimized 10-channel (5 differential) single-pole, double-throw switch for use in high speed applications. The TS5MP646 is designed to facilitate multiple MIPI compliant devices to connect to a single CSI/DSI, C-PHY/D-PHY module.

The device has a bandwidth of 3 GHz, low channel-to-channel skew with little signal degradation, and wide margins to compensate for layout losses. The device's low current consumption meets the needs of low power applications, including mobile phones and other personal electronics.

#### Device Information<sup>(1)</sup>

PART NUMBER	PACKAGE	BODY SIZE (NOM)
TS5MP646	DSBGA (YFP)	2.42 mm x 2.42 mm

(1) For all available packages, see the orderable addendum at the end of the data sheet.

#### Simplified D-PHY Schematic

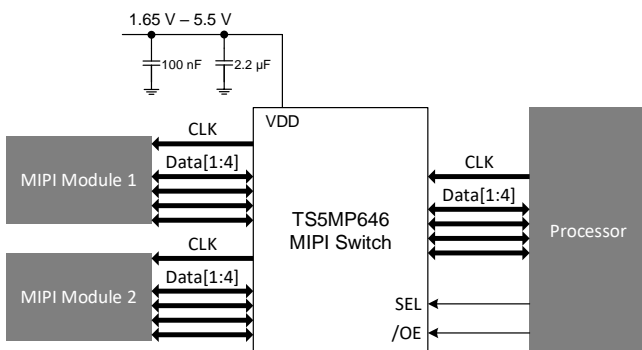

#### Simplified C-PHY Schematic

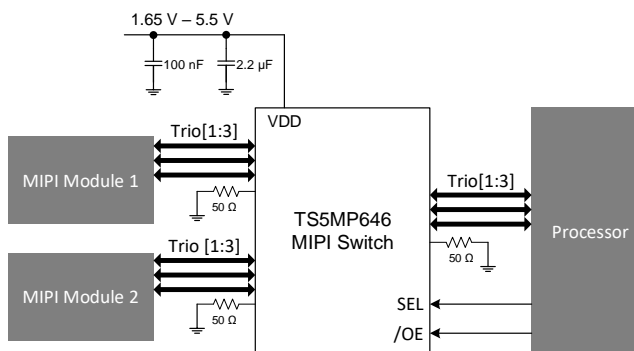

## Table of Contents

<b>1 Features</b> .....	1	8.4 Device Functional Modes.....	19
<b>2 Applications</b> .....	1	<b>9 Application and Implementation</b> .....	20
<b>3 Description</b> .....	1	9.1 Application Information.....	20
<b>4 Revision History</b> .....	2	9.2 Typical Application .....	20
<b>5 Pin Configuration and Functions</b> .....	3	<b>10 Power Supply Recommendations</b> .....	27
<b>6 Specifications</b> .....	4	<b>11 Layout</b> .....	28
6.1 Absolute Maximum Ratings .....	4	11.1 Layout Guidelines .....	28
6.2 ESD Ratings.....	4	11.2 Layout Example .....	28
6.3 Recommended Operating Conditions.....	5	<b>12 Device and Documentation Support</b> .....	29
6.4 Thermal Information .....	5	12.1 Documentation Support .....	29
6.5 Electrical Characteristics.....	5	12.2 Receiving Notification of Documentation Updates	29
6.6 Typical Characteristics .....	9	12.3 Community Resources.....	29
<b>7 Parameter Measurement Information</b> .....	10	12.4 Trademarks .....	29
<b>8 Detailed Description</b> .....	16	12.5 Electrostatic Discharge Caution.....	29
8.1 Overview .....	16	12.6 Glossary .....	29
8.2 Functional Block Diagram .....	16	<b>13 Mechanical, Packaging, and Orderable</b>	
8.3 Feature Description.....	17	<b>Information</b> .....	29

## 4 Revision History

NOTE: Page numbers for previous revisions may differ from page numbers in the current version.

<b>Changes from Revision D (January 2019) to Revision E</b>	<b>Page</b>
• Added min differential bandwidth specification 2.7 GHz .....	8
• Changed typ differential bandwidth specification to 4.1 GHz .....	8

<b>Changes from Revision C (August 2018) to Revision D</b>	<b>Page</b>
• Added the Simplified D-PHY and C-PHY Schematic .....	1
• Added the Typical D-PHY and C-PHY Application circuits .....	20
• Added Eye diagrams to the Application Curves section.....	22
• Added the <i>MIPI D-PHY Application</i> section .....	23
• Added the <i>MIPI C-PHY Application</i> section .....	25

<b>Changes from Revision B (July 2018) to Revision C</b>	<b>Page</b>
• Changed the <i>Applications</i> list .....	1

  

<b>Changes from Revision A (March 2018) to Revision B</b>	<b>Page</b>
• Changed the BODY SIZE (NOM) in the <i>Device Information</i> table From: 2.459 x 2.459 To: 2.42 x 2.42 .....	1

<b>Changes from Original (January 2018) to Revision A</b>	<b>Page</b>
• Changed the BODY SIZE (NOM) in the <i>Device Information</i> table From: 2.459 x 2.459 To: 2.42 x 2.42 .....	1

## 5 Pin Configuration and Functions

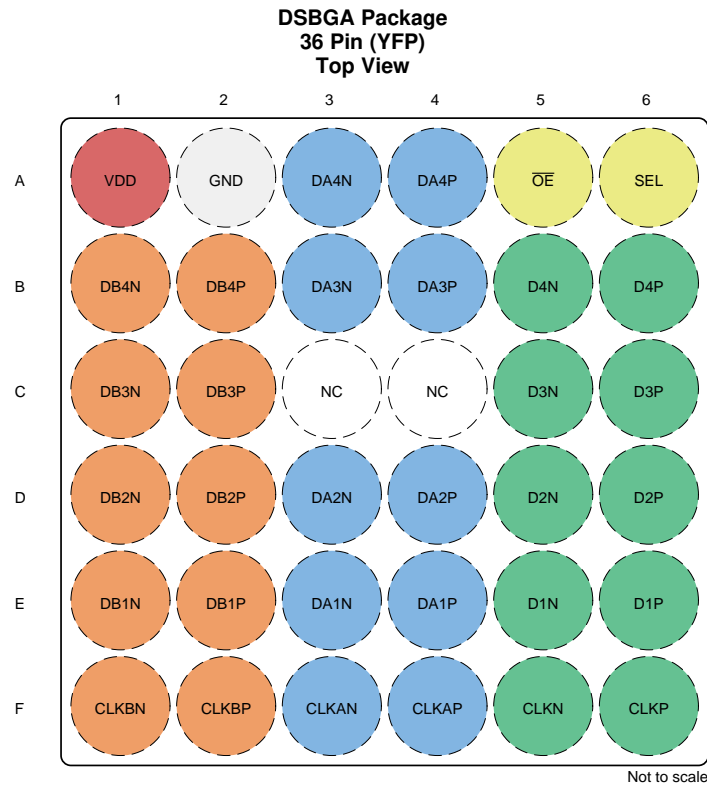

### Pin Functions

PIN		I/O	DESCRIPTION
NAME	NO.		
VDD	A1	PWR	Power supply input
GND	A2	GND	Device Ground
DA4N	A3	I/O	Differential I/O
DA4P	A4	I/O	Differential I/O
$\overline{\text{OE}}$	A5	I	Output enable (Active Low)
SEL	A6	I	Channel Select
DB4N	B1	I/O	Differential I/O
DB4P	B2	I/O	Differential I/O
DA3N	B3	I/O	Differential I/O
DA3P	B4	I/O	Differential I/O
D4N	B5	I/O	Differential I/O
D4P	B6	I/O	Differential I/O
DB3N	C1	I/O	Differential I/O
DB3P	C2	I/O	Differential I/O
NC	C3	-	No connect
NC	C4	-	No connect
D3N	C5	I/O	Differential I/O
D3P	C6	I/O	Differential I/O
DB2N	D1	I/O	Differential I/O
DB2P	D2	I/O	Differential I/O
DA2N	D3	I/O	Differential I/O

### Pin Functions (continued)

PIN		I/O	DESCRIPTION
NAME	NO.		
DA2P	D4	I/O	Differential I/O
D2N	D5	I/O	Differential I/O
D2P	D6	I/O	Differential I/O
DB1N	E1	I/O	Differential I/O
DB1P	E2	I/O	Differential I/O
DA1N	E3	I/O	Differential I/O
DA1P	E4	I/O	Differential I/O
D1N	E5	I/O	Differential I/O
D1P	E6	I/O	Differential I/O
CLKBN	F1	I/O	Differential I/O
CLKBP	F2	I/O	Differential I/O
CLKAN	F3	I/O	Differential I/O
CLKAP	F4	I/O	Differential I/O
CLKN	F5	I/O	Differential I/O
CLKP	F6	I/O	Differential I/O

## 6 Specifications

### 6.1 Absolute Maximum Ratings

over operating free-air temperature range (unless otherwise noted)<sup>(1)</sup>

		MIN	MAX	UNIT
$V_{DD}$	Supply Voltage	-0.5	6	V
$V_{I/O}$	Analog voltage range (DxN, CLKN, DxP, CLKP, DAxN, CLKAN, DAxP, CLKAP, DBxN, CLKBN, DBxP, CLKBP)	-0.5	4	V
$V_{SEL}, \overline{V_{OE}}$	Digital Input Voltage (SEL, /OE)	-0.5	6	V
$T_J$	Junction temperature	-65	150	°C
$T_{stg}$	Storage temperature	-65	150	°C

- (1) Stresses beyond those listed under *Absolute Maximum Rating* may cause permanent damage to the device. These are stress ratings only, which do not imply functional operation of the device at these or any other conditions beyond those indicated under *Recommended Operating Condition*. Exposure to absolute-maximum-rated conditions for extended periods may affect device reliability.

### 6.2 ESD Ratings

		VALUE	UNIT
$V_{(ESD)}$	Electrostatic discharge	Human body model (HBM), per ANSI/ESDA/JEDEC JS-001, all pins <sup>(1)</sup>	±2000
		Charged device model (CDM), per JEDEC specification JESD22-C101, all pins <sup>(2)</sup>	±250

- (1) JEDEC document JEP155 states that 500-V HBM allows safe manufacturing with a standard ESD control process. [Following sentence optional; see the wiki.] Manufacturing with less than 500-V HBM is possible with the necessary precautions. [Following sentence optional; see the wiki.] Pins listed as ± WWW V and/or ± XXX V may actually have higher performance.
- (2) JEDEC document JEP157 states that 250-V CDM allows safe manufacturing with a standard ESD control process. [Following sentence optional; see the wiki.] Manufacturing with less than 250-V CDM is possible with the necessary precautions. [Following sentence optional; see the wiki.] Pins listed as ± YYY V and/or ± ZZZ V may actually have higher performance.

### 6.3 Recommended Operating Conditions

over operating free-air temperature range (unless otherwise noted)

		MIN	NOM	MAX	UNIT
V <sub>DD</sub>	Supply Voltage	1.65		5.5	V
V <sub>I/O</sub>	Analog voltage range (DxN, CLKN, DxP, CLKP, DAxN, CLKAN, DAxP, CLKAP, DBxN, CLKBN, DBxP, CLKBP)	0		3.6	V
V <sub>(SEL)</sub> V <sub>(OE)</sub>	Digital Input Voltage	0		5.5	V
I <sub>I/O</sub>	Continuous I/O current	-35		35	mA
T <sub>A</sub>	Operating ambient temperature	-40		85	°C
T <sub>J</sub>	Junction temperature	-65		150	°C

### 6.4 Thermal Information

THERMAL METRIC <sup>(1)</sup>		TS5MP646			UNIT
		YFP			
		36			
R <sub>θJA</sub>	Junction-to-ambient thermal resistance	57.6			°C/W
R <sub>θJC(top)</sub>	Junction-to-case (top) thermal resistance	0.3			°C/W
R <sub>θJB</sub>	Junction-to-board thermal resistance	12.6			°C/W
Ψ <sub>JT</sub>	Junction-to-top characterization parameter	0.2			°C/W
Ψ <sub>JB</sub>	Junction-to-board characterization parameter	12.7			°C/W
R <sub>θJC(bot)</sub>	Junction-to-case (bottom) thermal resistance	N/A			°C/W

(1) For more information about traditional and new thermal metrics, see the [Semiconductor and IC Package Thermal Metrics](#) application report.

### 6.5 Electrical Characteristics

over operating free-air temperature range (unless otherwise noted)

PARAMETER	TEST CONDITIONS	MIN	TYP	MAX	UNIT		
<b>POWER SUPPLY</b>							
I <sub>DD</sub>	VDD Active Supply Current	V <sub>DD</sub> = 1.65 V to 5.5 V OE = 0 V SEL = 0 V to 5.5 V Dn, CLKn = 0 V		0	30	60	μA
I <sub>DD_PD</sub>	Power-down Supply current	V <sub>DD</sub> = 1.65 V to 5.5 V OE = V <sub>DD</sub> SEL = 0 V to 5.5 V Dn, CLKn = 0 V		0	0.1	1	μA
I <sub>DD_PD_1.8</sub>	Power-down Supply current	V <sub>DD</sub> = 1.65 V to 5.5 V OE = 1.8 V SEL = 0 V to 5.5 V Dn, CLKn = 0 V		0	0.1	10	μA
<b>DC CHARACTERISTICS</b>							
R <sub>ON_HS</sub>	On-state resistance	V <sub>DD</sub> = 1.65 V to 5.5 V OE = 0 V Dn, CLKn = -8 mA, 0.2 V DAn, DBn, CLKAN, CLKBn = 0.2 V, -8 mA			6	9	Ω
R <sub>ON_LP</sub>	On-state resistance	V <sub>DD</sub> = 1.65 V to 5.5 V OE = 0 V Dn, CLKn = -8 mA, 1.2 V DAn, DBn, CLKAN, CLKBn = 1.2 V, -8 mA			6	10	Ω

**Electrical Characteristics (continued)**

over operating free-air temperature range (unless otherwise noted)

PARAMETER		TEST CONDITIONS	MIN	TYP	MAX	UNIT
$R_{ON\_flat\_HS}$	On-state resistance flatness	$V_{DD} = 1.65\text{ V to }5.5\text{ V}$ $OE = 0\text{ V}$ Dn, CLKn = -8 mA, 0 V to 0.3 V DAn, DBn, CLKAn, CLKBn = 0 V to 0.3 V, -8 mA		0.1		$\Omega$
$R_{ON\_flat\_LP}$	On-state resistance flatness	$V_{DD} = 1.65\text{ V to }5.5\text{ V}$ $OE = 0\text{ V}$ Dn, CLKn = -8 mA, 0 V to 1.3 V DAn, DBn, CLKAn, CLKBn = 0 V to 1.3 V, -8 mA		0.9		$\Omega$
$D_{RON\_HS}$	On-state resistance match between+and - paths	$V_{DD} = 1.65\text{ V to }5.5\text{ V}$ $OE = 0\text{ V}$ Dn, CLKn = -8 mA, 0.2 V DAn, DBn, CLKAn, CLKBn = 0.2 V, -8 mA		0.1		$\Omega$
$D_{RON\_LP}$	On-state resistance match between+and - paths	$V_{DD} = 1.65\text{ V to }5.5\text{ V}$ $OE = 0\text{ V}$ Dn, CLKn = -8 mA, 1.3 V DAn, DBn, CLKAn, CLKBn = 1.3 V, -8 mA		0.1		$\Omega$
$I_{OFF}$	Switch off leakage current	$V_{DD} = 1.65\text{ V to }5.5\text{ V}$ $OE = 0\text{ V to }5.5\text{ V}$ SEL = 0 V to 5.5 V Dn, CLKn = 0 V to 1.3 V DAn, DBn, CLKAn, CLKBn = 0 V to 1.3 V	-0.5		0.5	$\mu\text{A}$
$I_{OFF\_3\_6}$	Switch off leakage current	VDD = 0V,1.5V,1.65V,3.3V,5.5V /OE = 0V,1.5V,1.65V,3.3V,5.5V SEL= 0V,1.5V,1.65V,3.3V,5.5V DX,CLKX = 3.6V DAX,DBx,CLKAX,CLKBX = 3.6V	-10		10	$\mu\text{A}$
$I_{ON}$	Switch on leakage current	$V_{DD} = 1.65\text{ V to }5.5\text{ V}$ $OE = 0\text{ V}$ SEL = 0 V to 5.5 V Dn, CLKn = 0 V to 1.3 V DAn, DBn, CLKAn, CLKBn = 0 V to 1.3 V	-0.5		0.5	$\mu\text{A}$
$I_{ON\_3\_6}$	Switch on leakage current	VDD = 1.5V,1.65V,3.3V,5.5V /OE = 0V SEL= 0V,1.5V,1.65V,3.3V,5.5V DX,CLKX = 3.6V DAX,DBx,CLKAX,CLKBX = 3.6V	-50		50	$\mu\text{A}$
<b>DYNAMIC CHARACTERISTICS</b>						
$t_{SWITCH}$	Switching time between channels	$V_{DD} = 1.65\text{ V to }5.5\text{ V}$ $OE = 0\text{ V}$ Dn, CLKn = 0.6 V DAn, DBn, CLKAn, CLKBn: $R_L = 50\ \Omega$ , $C_L = 1\text{ pF}$			1.5	$\mu\text{s}$
$t_{SWITCH\_CP}$	Switching time between channels by charge pump	VDD = 1.5V,1.65V,3.3V,5.5V /OE = 0V DX, CLKX = 0.6 V DAX, DBX, CLKAX, CLKBX: $R_L=50\Omega, C_L=5\text{pF}$			50	$\mu\text{s}$
$f_{SEL\_MAX}$	Maximum toggling frequency for the SEL line	$V_{DD} = 1.65\text{ V to }5.5\text{ V}$ Dn, CLKn = 0.6 V DAn, DBn, CLKAn, CLKBn: $R_L = 50\ \Omega$ , $C_L = 1\text{ pF}$			100	kHz

**Electrical Characteristics (continued)**

over operating free-air temperature range (unless otherwise noted)

PARAMETER		TEST CONDITIONS	MIN	TYP	MAX	UNIT
$t_{ON\_OE}$	Device turnon-time $\overline{OE}$ to switch on	$V_{DD} = 1.65\text{ V to }5.5\text{ V}$ Dn, CLKn = 0.6 V DAn, DBn, CLKAn, CLKBn: $R_L = 50\ \Omega$ , $C_L = 1\text{ pF}$		50	300	$\mu\text{s}$
$t_{ON\_VDD}$	Device turnon-time VDD to switch on	$V_{DD} = 0\text{ V to }5.5\text{ V}$ Dn, CLKn = 0.6 V DAn, DBn, CLKAn, CLKBn: $R_L = 50\ \Omega$ , $C_L = 1\text{ pF}$		50	300	$\mu\text{s}$
$t_{OFF\_OE}$	Device turnoff time $\overline{OE}$ to switch off	$V_{DD} = 1.65\text{ V to }5.5\text{ V}$ Dn, CLKn = 0.6 V DAn, DBn, CLKAn, CLKBn: $R_L = 50\ \Omega$ , $C_L = 1\text{ pF}$		0.5	1	$\mu\text{s}$
$t_{OFF\_VDD}$	Device turnoff time VDD to switch off	$V_{DD} = 5\text{ V to }0\text{ V}$ $V_{DD}$ ramp rate = 250 $\mu\text{s}$ Dn, CLKn = 0.6 V DAn, DBn, CLKAn, CLKBn: $R_L = 50\ \Omega$ , $C_L = 1\text{ pF}$		0.5	1	ms
$t_{MIN\_OE}$	Minimum pulse width for $\overline{OE}$	$V_{DD} = 1.65\text{ V to }5.5\text{ V}$ Dn, CLKn = 0.6 V DAn, DBn, CLKAn, CLKBn: $R_L = 50\ \Omega$ , $C_L = 1\text{ pF}$	500			ns
$t_{BBM}$	Break before make time	$V_{DD} = 1.65\text{ V to }5.5\text{ V}$ $OE = 0\text{ V}$ Dn, CLKn = $R_L = 50\ \Omega$ , $C_L = 1\text{ pF}$ DAn, DBn, CLKAn, CLKBn: 0.6 V	50			ns
$t_{SKEW}$	Intrapair skew	$V_{DD} = 1.65\text{ V to }5.5\text{ V}$ $OE = 0\text{ V}$ Dn, CLKn = 0.3 V DnX, DBn, CLKAn, CLKBn: $R_L = 50\ \Omega$ , $C_L = 1\text{ pF}$		1		ps
$t_{SKEW}$	Interpair Skew	$V_{DD} = 1.65\text{ V to }5.5\text{ V}$ $OE = 0\text{ V}$ Dn, CLKn = 0.3 V DAn, DBn, CLKAn, CLKBn: $R_L = 50\ \Omega$ , $C_L = 1\text{ pF}$		4		ps
$t_{PD}$	Propagation delay with 100 ps rise time	$V_{DD} = 1.65\text{ V to }5.5\text{ V}$ $OE = 0\text{ V}$ Dn, CLKn = 0.6 V DAn, DBn, CLKAn, CLKBn: $R_L = 50\ \Omega$ , $C_L = 1\text{ pF}$ $t_{RISE} = 100\text{ ps}$		40		ps
$O_{ISO}$	Differential off isolation	$V_{DD} = 1.65\text{ V to }5.5\text{ V}$ $OE = 0\text{ V}$ , $V_{DD}$ $SEL = 0\text{ V}$ , $V_{DD}$ Dn, CLKn, DAn, DBn, CLKAn, CLKBn: $R_S = 50\ \Omega$ , $R_L = 50\ \Omega$ , $C_L = 1\text{ pF}$ $V_{IO} = 200\text{ mV} + 200\text{ mV}_{PP}$ (differential) $f = 1250\text{ MHz}$		-20		dB
$X_{TALK}$	Differential channel to channel crosstalk	$V_{DD} = 1.65\text{ V to }5.5\text{ V}$ $OE = 0\text{ V}$ , $V_{DD}$ $SEL = 0\text{ V}$ , $V_{DD}$ Dn, CLKn, DAn, DBn, CLKAn, CLKBn: $R_S = 50\ \Omega$ , $R_L = 50\ \Omega$ , $C_L = 1\text{ pF}$ $V_{IO} = 200\text{ mV} + 200\text{ mV}_{PP}$ (differential) $f = 1250\text{ MHz}$		-40		dB

**Electrical Characteristics (continued)**

over operating free-air temperature range (unless otherwise noted)

PARAMETER		TEST CONDITIONS	MIN	TYP	MAX	UNIT
BW	Differential Bandwidth	$V_{DD} = 1.65 \text{ V to } 5.5 \text{ V}$ $OE = 0 \text{ V}$ $SEL = 0 \text{ V, } V_{DD}$ Dn, CLKn, DAn, DBn, CLKAn, CLKBn: $R_S = 50 \Omega, R_L = 50 \Omega, C_L = 1 \text{ pF}$ $V_{I/O} = 200 \text{ mV} + 200 \text{ mV}_{PP}$ (differential) $f = 1250 \text{ MHz}$	2.7	4.1		GHz
$I_{LOSS}$	Insertion Loss	$V_{DD} = 1.65 \text{ V to } 5.5 \text{ V}$ $OE = 0 \text{ V}$ $SEL = 0 \text{ V, } V_{DD}$ Dn, CLKn, DAn, DBn, CLKAn, CLKBn: $R_S = 50 \Omega, R_L = 50 \Omega, C_L = 1 \text{ pF}$ $V_{I/O} = 200 \text{ mV} + 200 \text{ mV}_{PP}$ (differential) $f = 100 \text{ kHz}$	-0.65			dB
$C_{OFF}$	Off capacitance	$V_{DD} = 1.65 \text{ V to } 5.5 \text{ V}$ $OE = 0 \text{ V, } V_{DD}$ $SEL = 0 \text{ V, } V_{DD}$ Dn, CLKn, DAn, DBn, CLKAn, CLKBn = $0 \text{ V, } 0.2 \text{ V}$ $f = 1250 \text{ MHz}$		1.5		pF
$C_{ON}$	On capacitance	$V_{DD} = 1.65 \text{ V to } 5.5 \text{ V}$ $OE = 0 \text{ V}$ $SEL = 0 \text{ V, } V_{DD}$ Dn, CLKn, DAn, DBn, CLKAn, CLKBn = $0 \text{ V, } 0.2 \text{ V}$ $f = 1250 \text{ MHz}$		1.5		pF
<b>DIGITAL CHARACTERISTICS</b>						
$V_{IH}$	Input logic high (SEL, $\overline{OE}$ )	$V_{I/O} = 0.6 \text{ V } R_L = 50 \Omega, C_L = 5 \text{ pF}$	1.425		5.5	V
$V_{IL}$	Input logic low (SEL, /OE)	$V_{I/O} = 0.6 \text{ V } R_L = 50 \Omega, C_L = 5 \text{ pF}$	0		0.5	V
$I_{IH}$	Input high leakage current (SEL, /OE)	$V_{I/O} = 0.6 \text{ V } R_L = 50 \Omega, C_L = 5 \text{ pF}$	-5		5	$\mu\text{A}$
$I_{IL}$	Input low leakage current (SEL, /OE)	$V_{I/O} = 0.6 \text{ V } R_L = 50 \Omega, C_L = 5 \text{ pF}$	-5		5	$\mu\text{A}$
$R_{PD}$	Internal pull-down resistance on digital input pins	$V_{I/O} = 0.6 \text{ V } R_L = 50 \Omega, C_L = 5 \text{ pF}$		6		M $\Omega$
$C_I$	Digital Input capacitance (SEL, /OE)	$f = 1 \text{ MHz}$		5		pF



## 6.6 Typical Characteristics

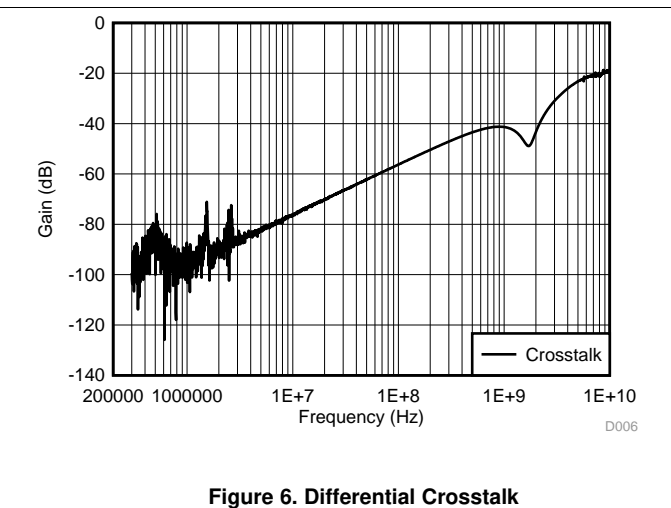
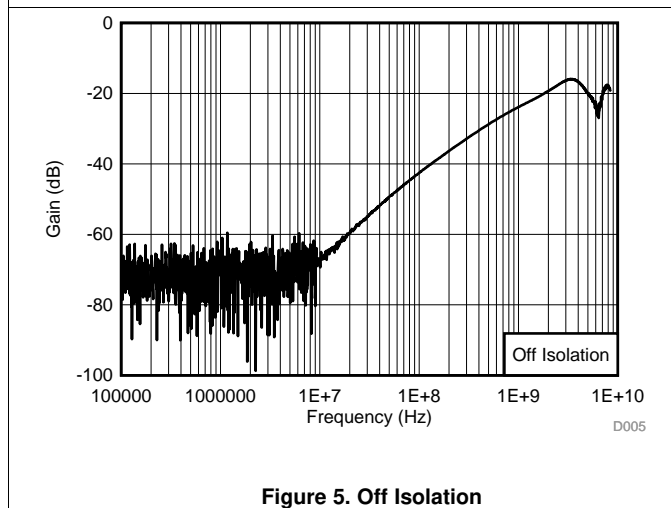
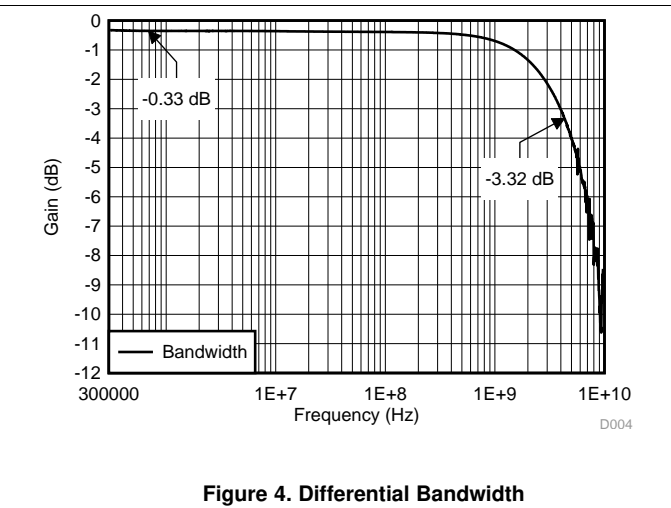
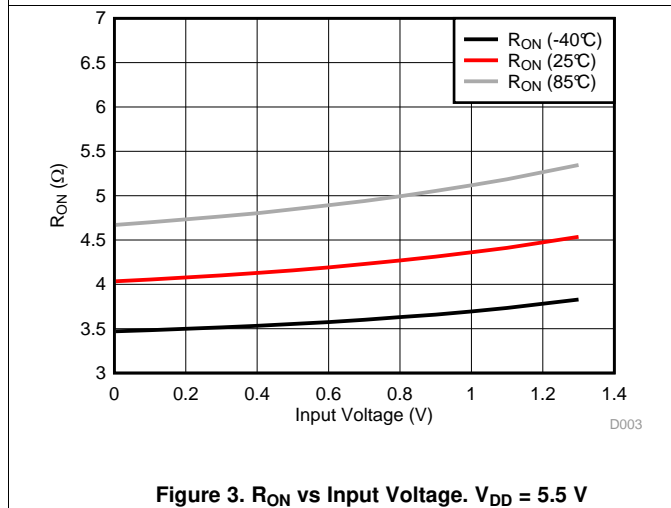
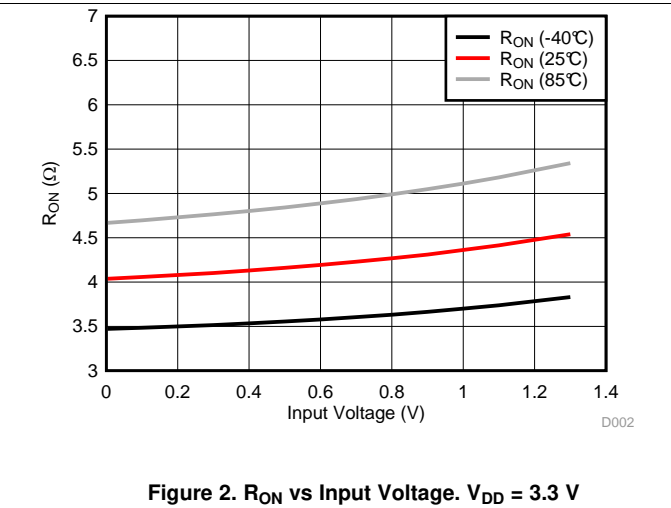
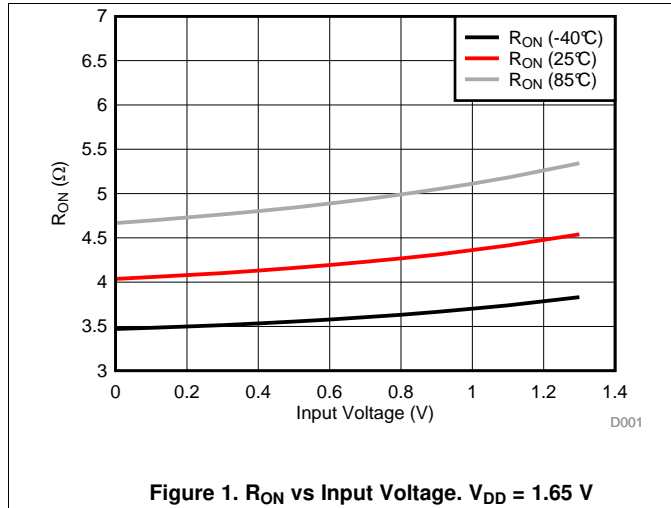

## 7 Parameter Measurement Information

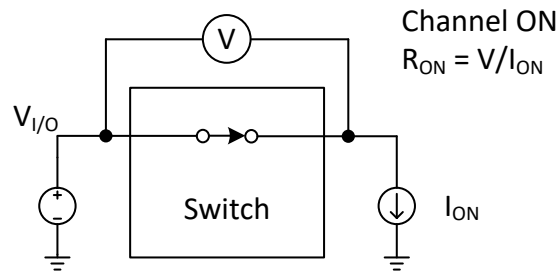

Copyright © 2018, Texas Instruments Incorporated

Figure 7. On Resistance

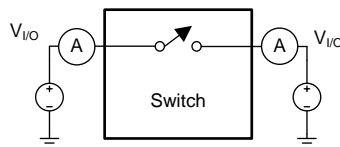

Figure 8. Off Leakage

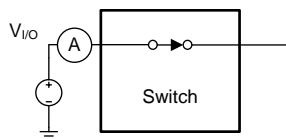
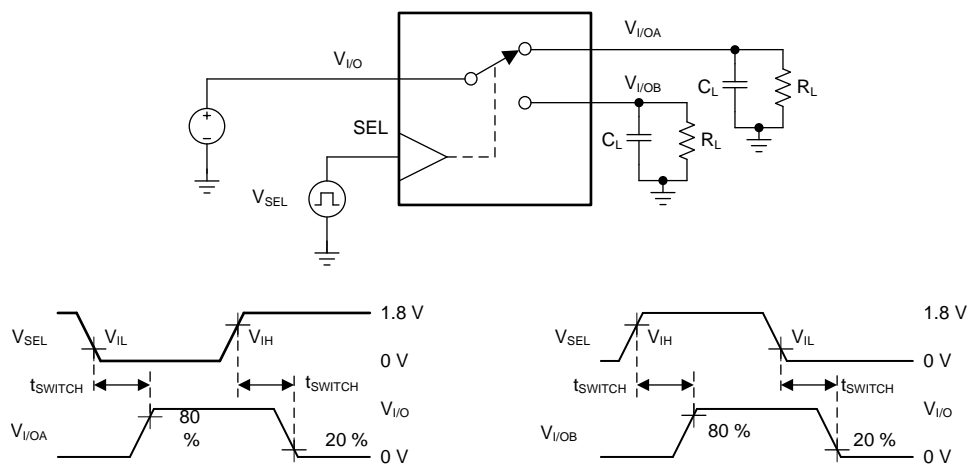

Figure 9. On Leakage



Copyright © 2018, Texas Instruments Incorporated

- (1) All input pulses are supplied by generators having the following characteristics: PRR  $\leq$  10 MHz,  $Z_O = 50 \Omega$ ,  $t_r = 3$  ns,  $t_f = 3$  ns.
- (2)  $C_L$  includes probe and jig capacitance.

Figure 10.  $t_{SWITCH}$  Timing

Parameter Measurement Information (continued)

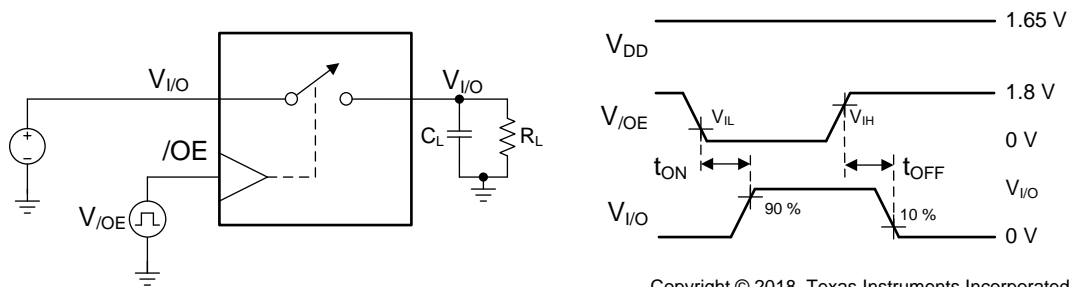

Copyright © 2018, Texas Instruments Incorporated

- (1) All input pulses are supplied by generators having the following characteristics: PRR ≤ 10 MHz, Z<sub>O</sub> = 50 Ω, t<sub>r</sub> = 3 ns, t<sub>f</sub> = 3 ns.
- (2) C<sub>L</sub> includes probe and jig capacitance.

Figure 11. t<sub>ON</sub> and t<sub>OFF</sub> Timing for  $\overline{OE}$

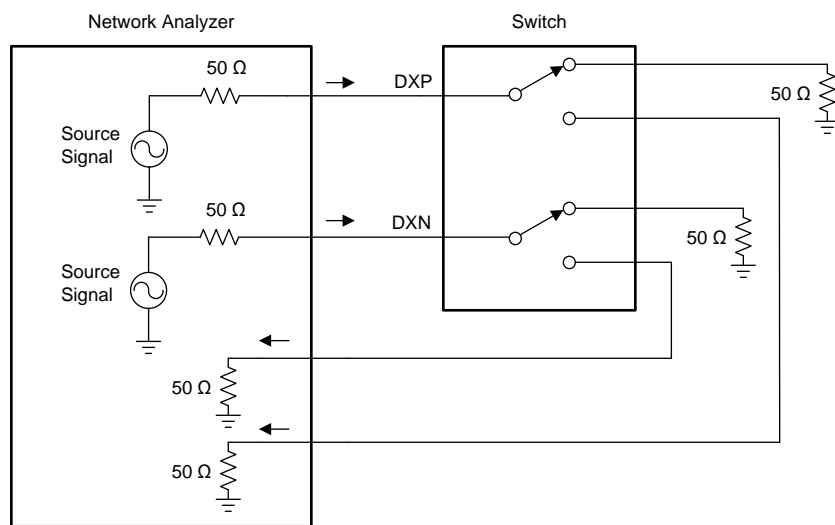

Copyright © 2018, Texas Instruments Incorporated

Figure 12. Off Isolation

**Parameter Measurement Information (continued)**

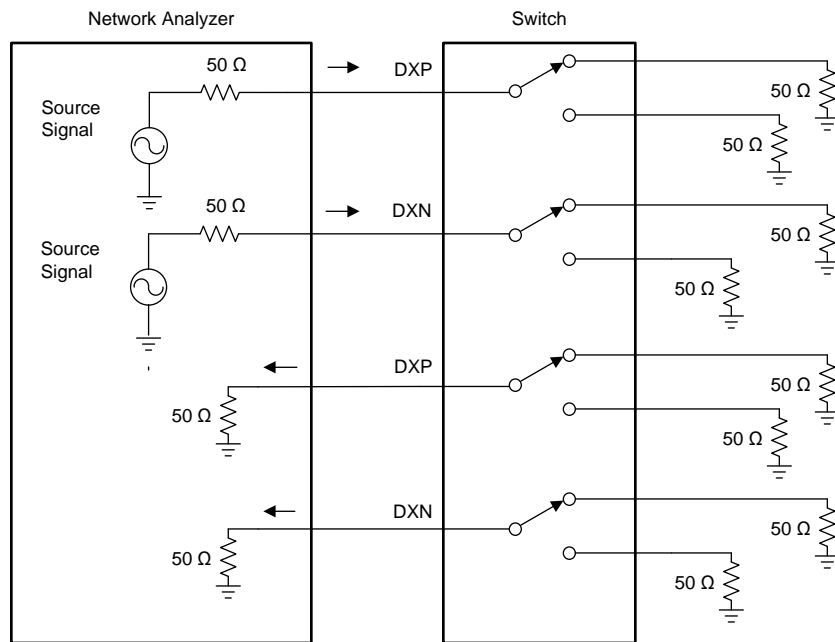

Copyright © 2018, Texas Instruments Incorporated

**Figure 13. Crosstalk**

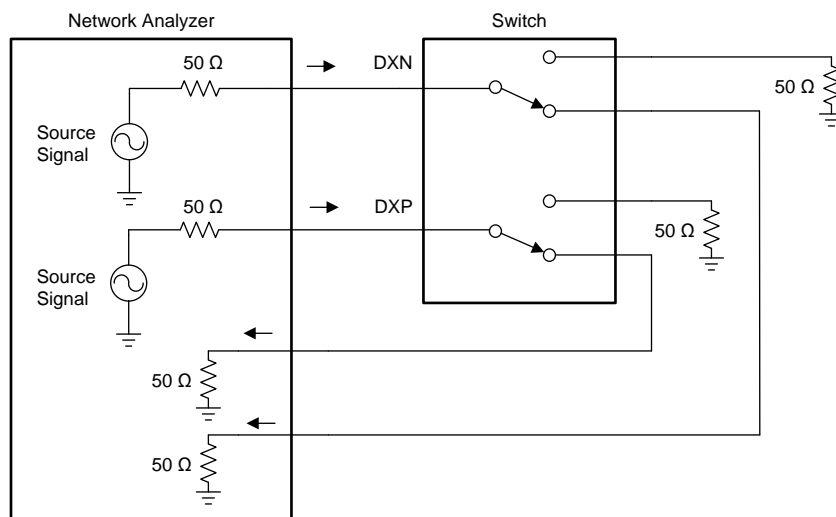

Copyright © 2017, Texas Instruments Incorporated

**Figure 14. Bandwidth and Insertion Loss**

Parameter Measurement Information (continued)

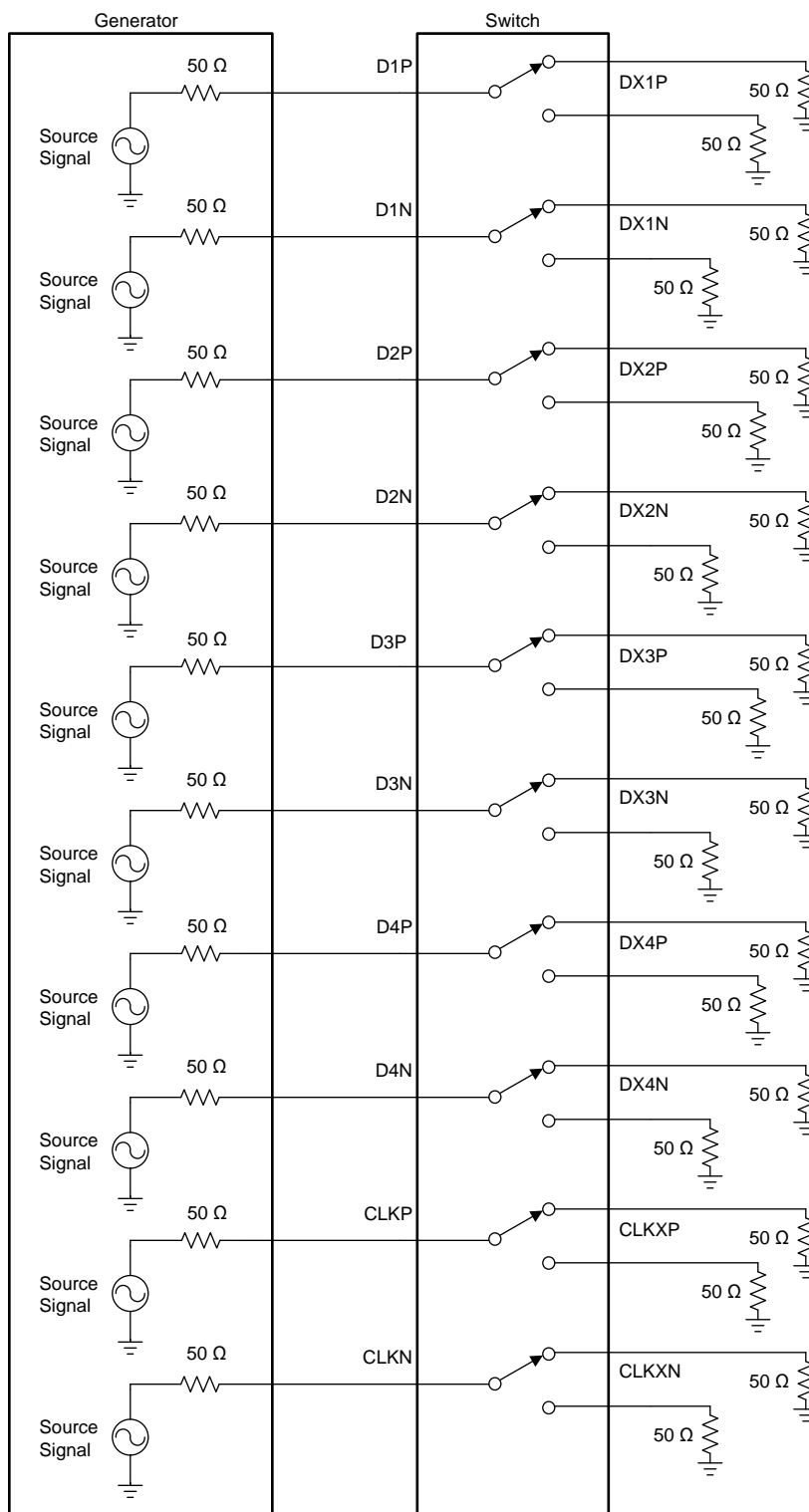

Copyright © 2017, Texas Instruments Incorporated

Figure 15.  $t_{PD}$ ,  $t_{SKEW(INTRA)}$  and  $t_{SKEW(INTER)}$  Setup

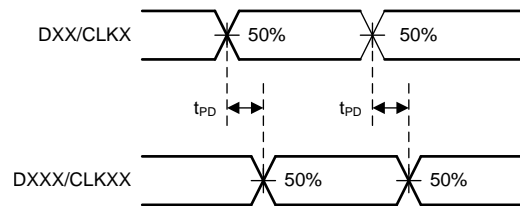
**Parameter Measurement Information (continued)**

- (1) All input pulses are supplied by generators having the following characteristics:  $PRR \leq 10 \text{ MHz}$ ,  $Z_O = 50 \Omega$ ,  $t_r = 100 \text{ ps}$ ,  $t_f = 100 \text{ ps}$ .
- (2)  $C_L$  includes probe and jig capacitance.

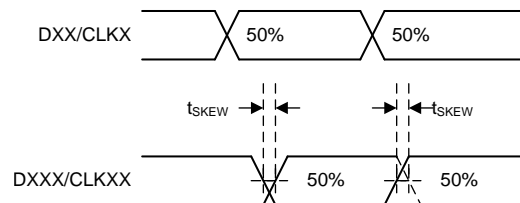
**Figure 16.  $t_{PD}$** 

- (1) All input pulses are supplied by generators having the following characteristics:  $PRR \leq 10 \text{ MHz}$ ,  $Z_O = 50 \Omega$ ,  $t_r = 100 \text{ ps}$ ,  $t_f = 100 \text{ ps}$ .
- (2)  $C_L$  includes probe and jig capacitance.

**Figure 17.  $t_{SKEW(INTRA)}$**

Parameter Measurement Information (continued)

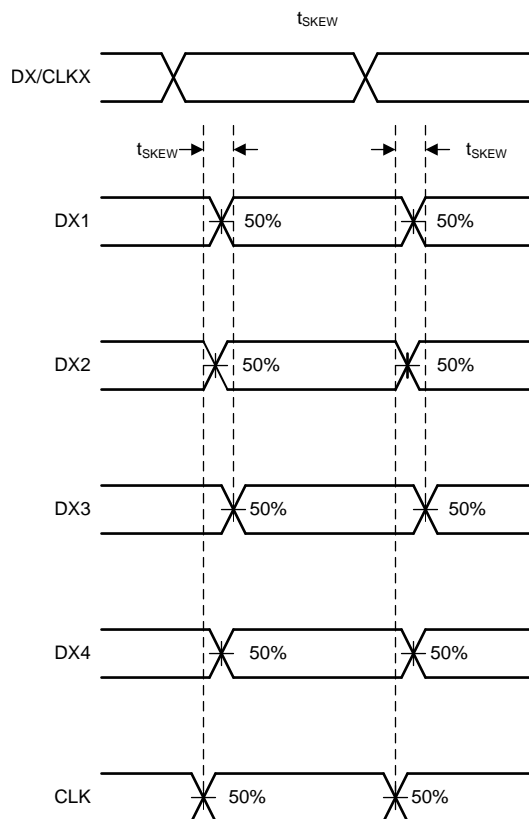

- (1) All input pulses are supplied by generators having the following characteristics: PRR ≤ 10 MHz, Z<sub>O</sub> = 50 Ω , t<sub>r</sub> = 100 ps, t<sub>f</sub> = 100 ps.
- (2) C<sub>L</sub> includes probe and jig capacitance.
- (3) t<sub>SKEW</sub> is the max skew between all channels. Diagram exaggerates t<sub>SKEW</sub> to show measurement technique

Figure 18. t<sub>SKEW(INTER)</sub>

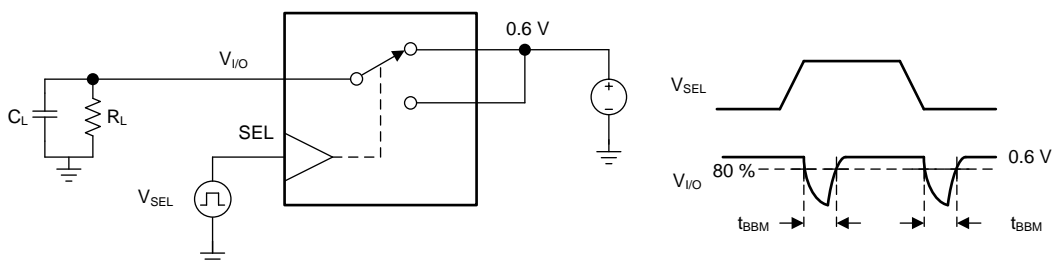

Copyright © 2017, Texas Instruments Incorporated

- (1) All input pulses are supplied by generators having the following characteristics: PRR ≤ 10 MHz, Z<sub>O</sub> = 50 Ω , t<sub>r</sub> = 3 ns, t<sub>f</sub> = 3 ns.
- (2) C<sub>L</sub> includes probe and jig capacitance.

Figure 19. t<sub>BBM</sub>

## 8 Detailed Description

### 8.1 Overview

The TS5MP646 is a high-speed 4 data lane 2:1 MIPI Switch. The device includes 10 channels (5 differential) with 4 differential data lanes and 1 differential clock lane for D-PHY, CSI or DSI. The switch allows a single MIPI port to interface between two MIPI modules, expanding the number of potential MIPI devices that can be used within a system that is MIPI port limited.

### 8.2 Functional Block Diagram

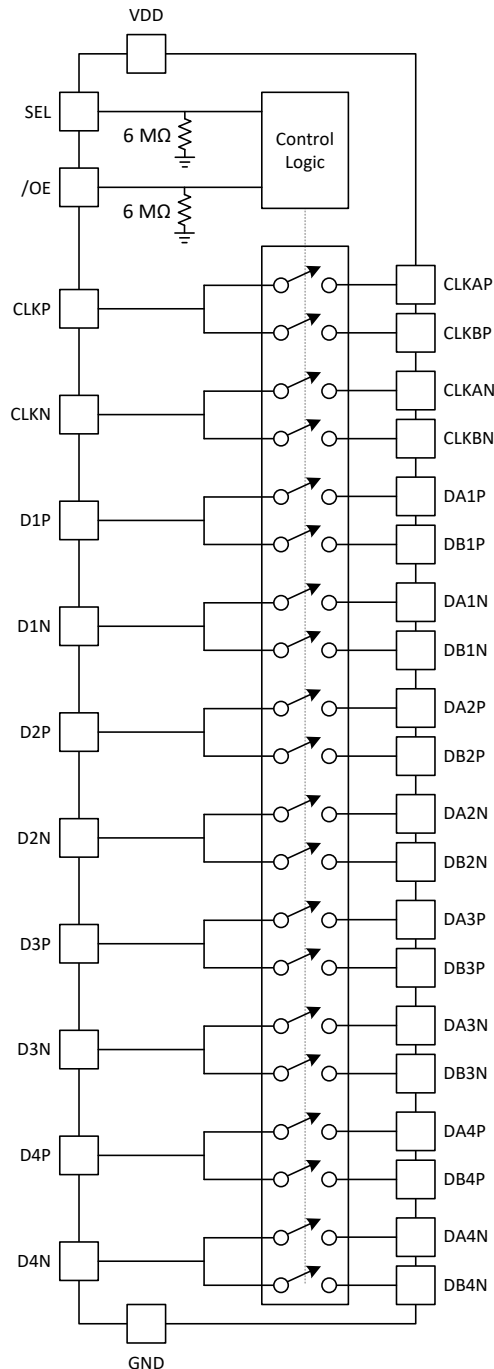

Copyright © 2018, Texas Instruments Incorporated



## 8.3 Feature Description

### 8.3.1 Powered-Off Protection

When the TS5MP646 is powered off ( $V_{DD} = 0\text{ V}$ ) the I/Os and digital logic pins of the device remains in a high impedance state. The crosstalk, off-isolation, and leakage will remain within the electrical specifications. This prevents errant voltages from reaching the rest of the system and maintains isolation when the system is powering up.

Figure 20 shows an example system containing a switch without powered-off protection with the following system level scenario.

1. Subsystem A powers up and starts sending information to Subsystem B that remains unpowered.
2. The I/O voltage back powers the supply rail in Subsystem B.
3. The digital logic is back powered and turns on the switch. The signal is transmitted to Subsystem B before it is powered and damages it.

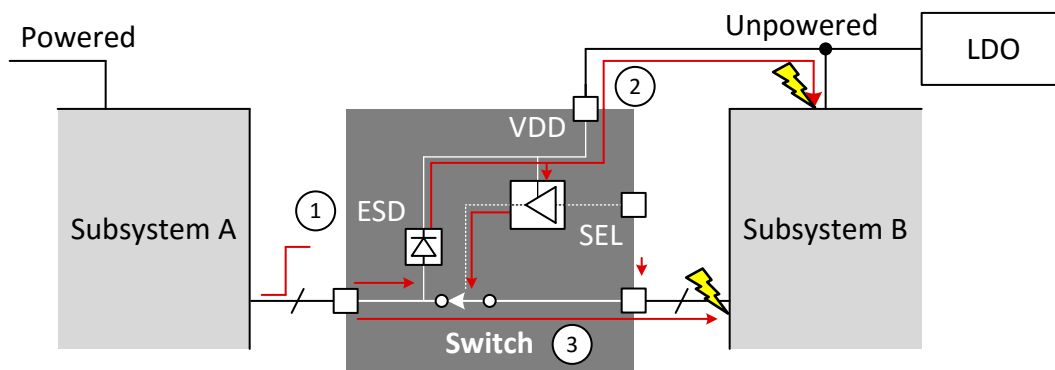

Figure 20. System Without Powered-Off Protection

With powered-off protection, the switch prevents back powering the supply and the switch remains high-impedance. Subsystem B remains protected.

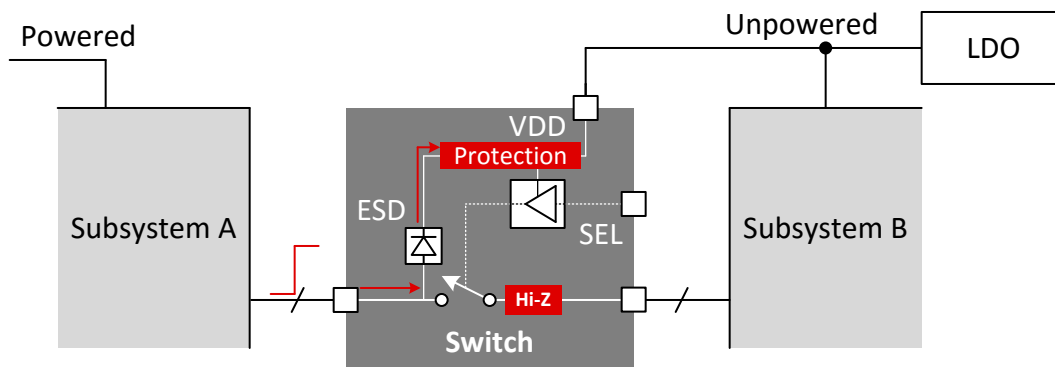

Figure 21. System With Powered-Off Protection

This features has the following system level benefits.

- Protects the system from damage.
- Prevents data from being transmitted unintentionally
- Eliminates the need for power sequencing solutions reducing BOM count and cost, simplifying system design and improving reliability.

## Feature Description (continued)

### 8.3.2 1.8-V Logic Compatible Inputs

The TS5MP646 has 1.8-V logic compatible digital inputs for switch control. Regardless of the  $V_{DD}$  voltage the digital input thresholds remained fixed, allowing a 1.8-V processor GPIO to control the TS5MP646 without the need for an external translator. This saves both space and BOM cost.

An example setup for a system without a 1.8-V logic compatible input is shown in [Figure 22](#). Here the supply mismatch between the processor and its GPIO output and the supply to the switch require a translator.

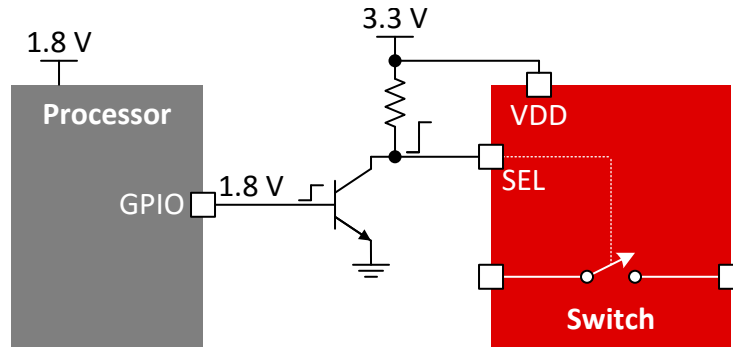

**Figure 22. System Without 1.8 V Logic Compatible Inputs**

With the 1.8 V logic compatibility in the TS5MP646, the translator is built in to the device so that the external components are no longer needed, simplifying the system design and overall cost.

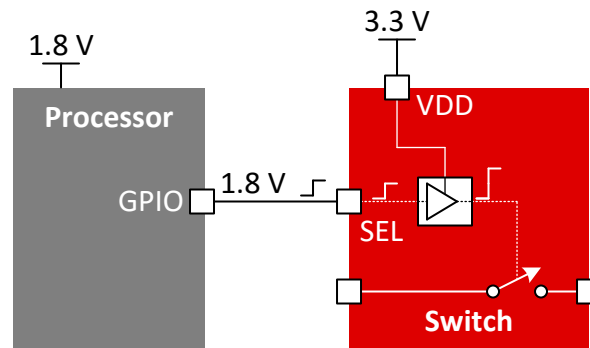

**Figure 23. System With 1.8 V Logic Compatible Inputs**

### 8.3.3 Low Power Disable Mode

The TS5MP646 has a low power mode that places all the signal paths in a high impedance state and lowers the current consumption while the device is not in use. To put the device in low power mode and disable the switch, the output enable pin  $\overline{OE}$  must be supplied with a logic high signal.

## 8.4 Device Functional Modes

### 8.4.1 Pin Functions

The SEL and  $\overline{OE}$  pins have a weak 6-M $\Omega$  pull-down to prevent floating input logic.

**Table 1. Function Table**

$\overline{OE}$	SEL	Function
H	X	I/O pins High-Impedance
L	L	CLK(P/N) = CLKA(P/N)
		Dn(P/N) = DAn(P/N)
L	H	CLK(P/N) = CLKB(P/N)
		Dn(P/N) = DBn(P/N)

### 8.4.2 Low Power Disable Mode

While the output enable pin  $\overline{OE}$  is supplied with a logic high, the device remains in low power disabled state. This reduces the current consumption substantially and the switches are high impedance. The SEL pin is ignored while the  $\overline{OE}$  remains high. Upon exiting low power mode, the switch status reflects the SEL pin as seen in [Table 1](#).

### 8.4.3 Switch Enabled Mode

While the output enable pin  $\overline{OE}$  is supplied with a logic low, the device remains in switch enabled mode.

## 9 Application and Implementation

### NOTE

Information in the following applications sections is not part of the TI component specification, and TI does not warrant its accuracy or completeness. TI's customers are responsible for determining suitability of components for their purposes. Customers should validate and test their design implementation to confirm system functionality.

### 9.1 Application Information

### 9.2 Typical Application

Figure 24 represents a typical application of the TS5MP646 MIPI switch. The TS5MP646 is used to switch signals between multiple MIPI modules and a single MIPI port on a processor. This expands the capabilities of a single port to handle multiple MIPI modules.

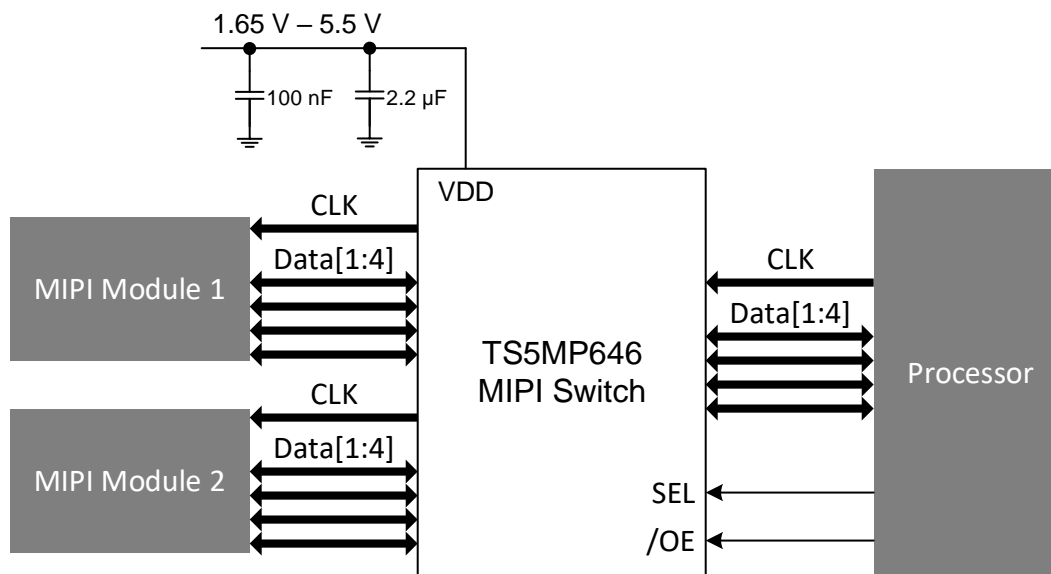

Figure 24. Typical D-PHY Application

Typical Application (continued)

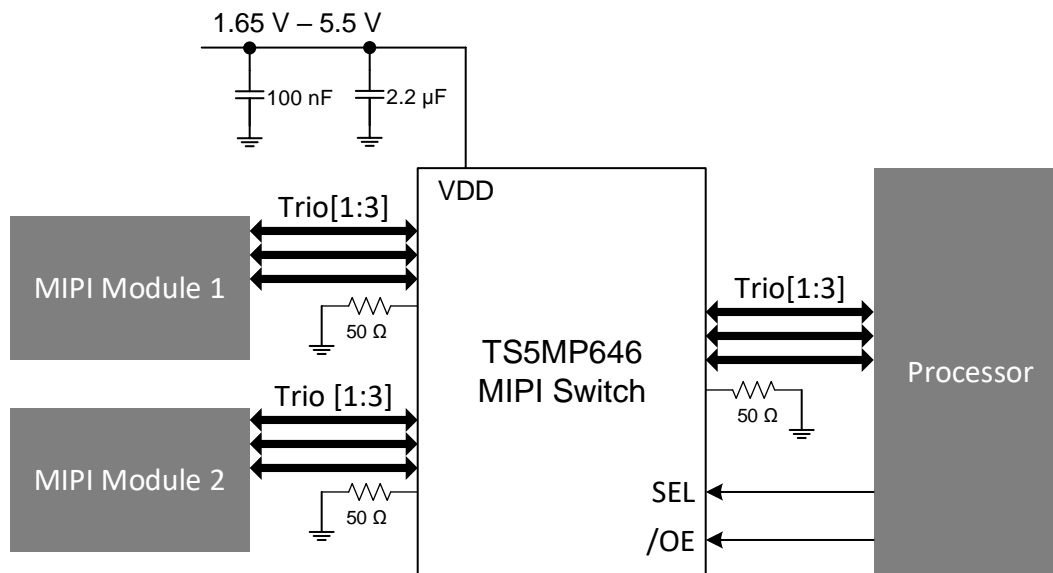

Figure 25. Typical C-PHY Application

9.2.1 Design Requirements

Design requirements of the MIPI standard must be followed. Supply pin decoupling capacitors of 2.2 μF and 100 nF are recommended for best performance. The TS5MP646 has internal 6-MΩ pulldown resistors on SEL and OE. The pulldown on these pins ensure that the digital remains in a non-floating state during system power-up to prevent shoot through current spikes and an unknown switch status. By default the switch will power up enabled and with the A path selected until driven externally by the processor.

9.2.2 Detailed Design Procedure

The TS5MP646 can be properly operated without any external components. However, TI recommends that unused I/O signal pins be connected to ground through a 50 Ω resistor to prevent signal reflections and maintain device performance. The NC pins of the device do not require any external connections or terminations and have no connection to the rest of the device internally.

The clock and data lanes can be interchanged as necessary to facilitate the best layout possible for the application. For example, the clock can be placed on the D1 channel and a data lane can be used on the CLK channel if this improves the layout. In addition, the signal lines of the TS5MP646 are routed single ended on the chip die. This makes the device suitable for both differential and single-ended high-speed systems.

## Typical Application (continued)

### 9.2.3 Application Curves

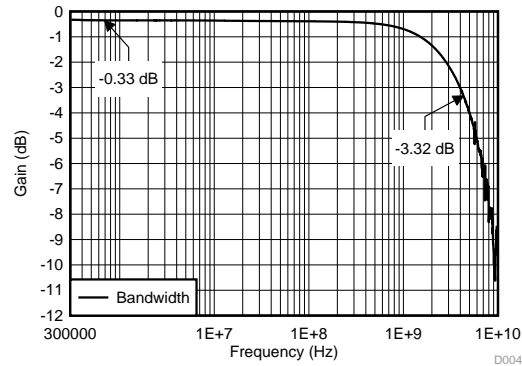

Figure 26. Differential Bandwidth

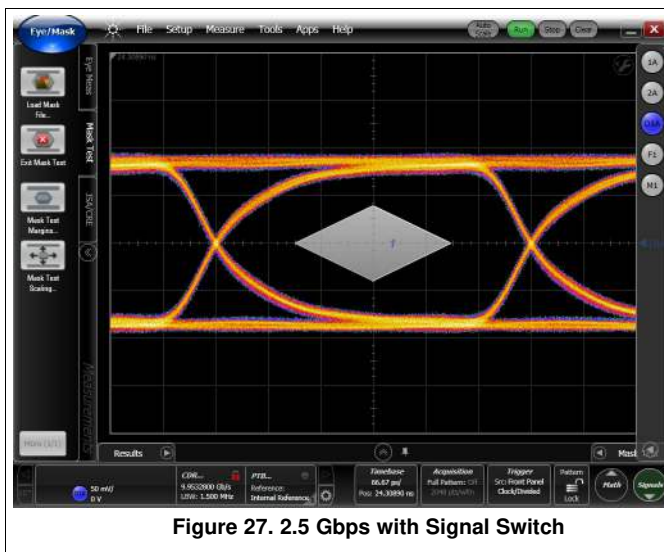

Figure 27. 2.5 Gbps with Signal Switch

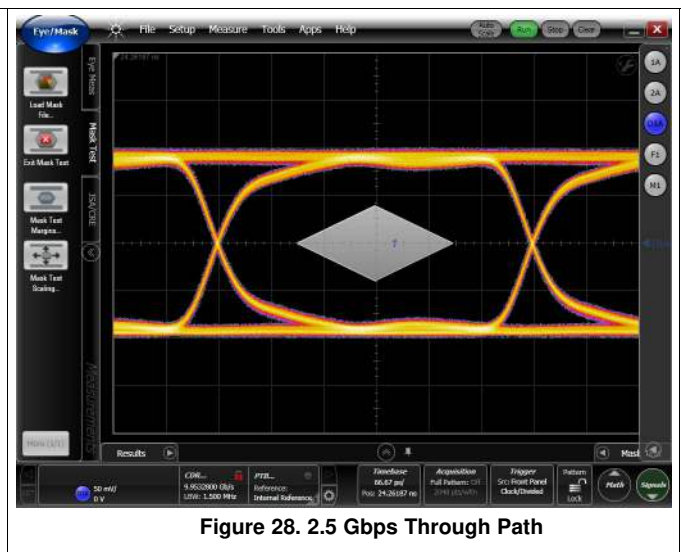

Figure 28. 2.5 Gbps Through Path

## Typical Application (continued)

### 9.2.3.1 MIPI D-PHY Application

The clock and data lanes can be interchanged as necessary to facilitate the best layout possible for the application. In addition, the signal lines of the TS5MP646 are routed single ended on the chip die. This makes the device suitable for both differential and single-ended high-speed systems. This also allows the positive and negative lines to be interchanged as necessary to facilitate the best layout possible for the application.

D-PHY application includes a differential clock and 4 differential datalanes. All the channels of the device perform similar and the clock or data signals may be interchanged as necessary to facilitate the best layout possible for the application.

Typical Application (continued)

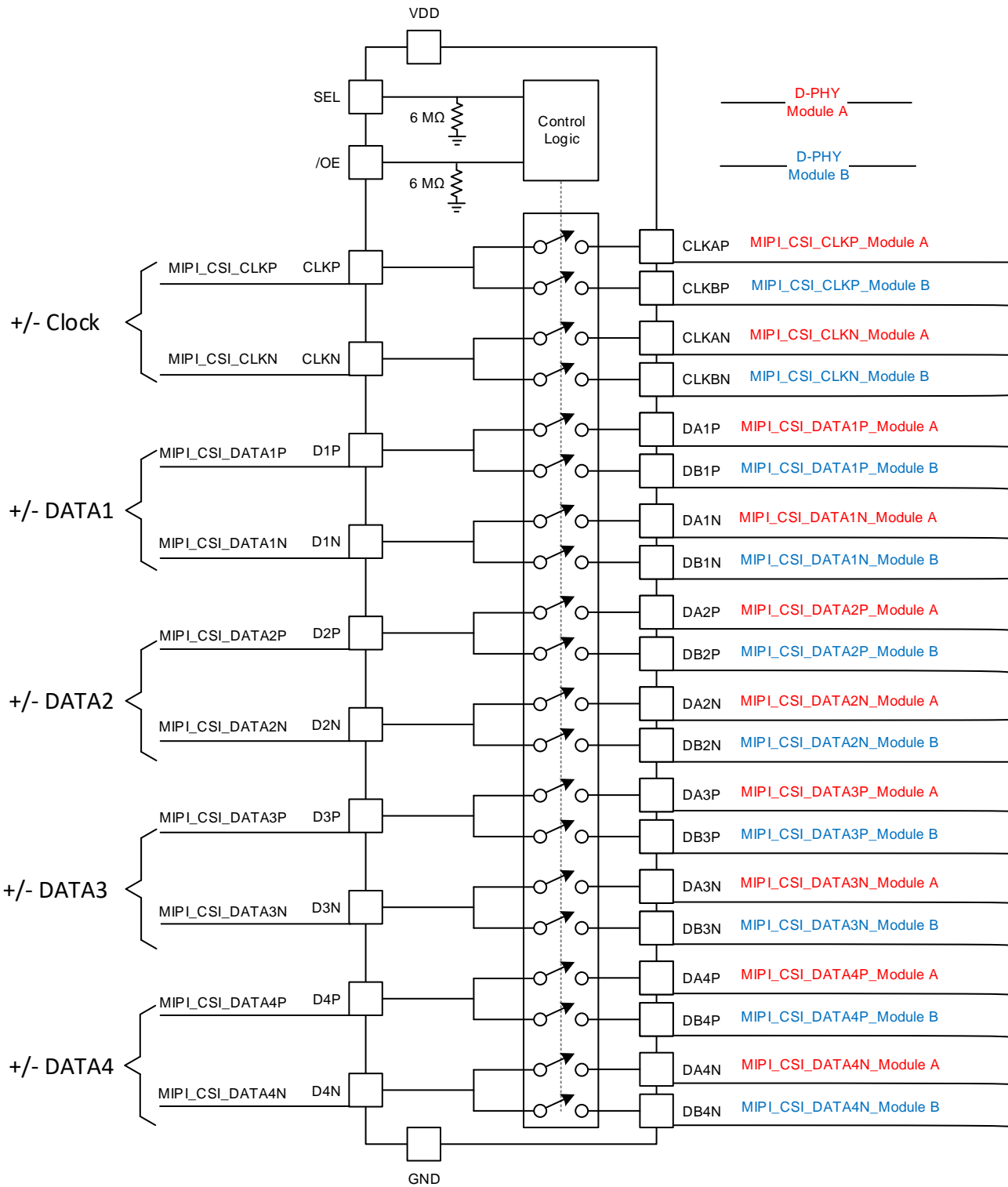

Figure 29. MIPI D-PHY Example Pinout



## Typical Application (continued)

### 9.2.3.2 MIPI C-PHY Application

The clock and data lanes can be interchanged as necessary to facilitate the best layout possible for the application. In addition, the signal lines of the TS5MP646 are routed single ended on the chip die. This makes the device suitable for both differential and single-ended high-speed systems. This also allows the positive and negative lines to be interchanged as necessary to facilitate the best layout possible for the application.

C-PHY application includes 3 trios of signals which may be routed on any channel which means there will be one unused channel on the TS5MP646. TI recommends that the unused I/O signal pin be connected to ground through a 50  $\Omega$  resistor to prevent signal reflections and maintain device performance.

Typical Application (continued)

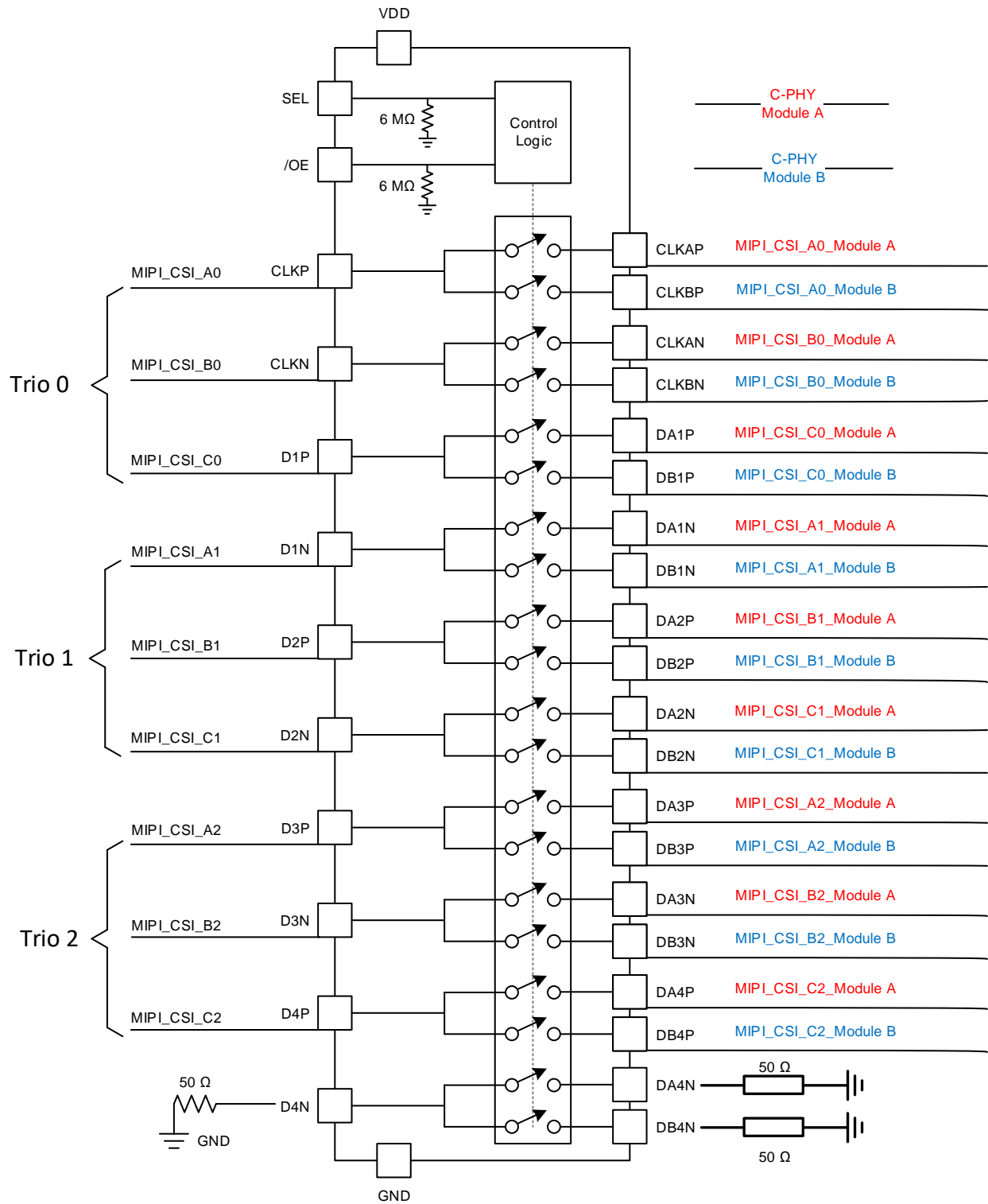

Figure 30. MIPI C-PHY Example Pinout

## 10 Power Supply Recommendations

When the TS5MP646 is powered off ( $V_{DD} = 0\text{ V}$ ), the I/Os of the device remains in a high-Z state. The crosstalk, off-isolation, and leakage remain within the electrical [Specifications](#). Power to the device is supplied through the VDD pin. Decoupling capacitors of 100 nF and 2.2  $\mu\text{F}$  are recommended on the supply.

## 11 Layout

### 11.1 Layout Guidelines

Place the supply de-coupling capacitors as close to the VDD and GND pin as possible. The spacing between the power traces, supply and ground, and the signal I/O lines, clock and data, should be a minimum of three times the trace width of the signal I/O lines to maintain signal integrity.

The characteristic impedance of the trace(s) must match that of the receiver and transmitter to maintain signal integrity. Route the high-speed traces using a minimum amount of vias and corners. This will reduce the amount of impedance changes.

When it becomes necessary to make the traces turn 90°, use two 45° turns or an arc instead of making a single 90° turn.

Do not route high-speed traces near crystals, oscillators, external clock signals, switching regulators, mounting holes or magnetic devices.

Avoid stubs on the signal lines.

All I/O signal traces should be routed over a continuous ground plane with no interruptions. The minimum width from the edge of the trace to any break in the ground plane must be 3 times the trace width. When routing on PCB inner signal layers, the high speed traces should be between two ground planes and maintain characteristic impedance.

High speed signal traces must be length matched as much as possible to minimize skew between data and clock lines.

### 11.2 Layout Example

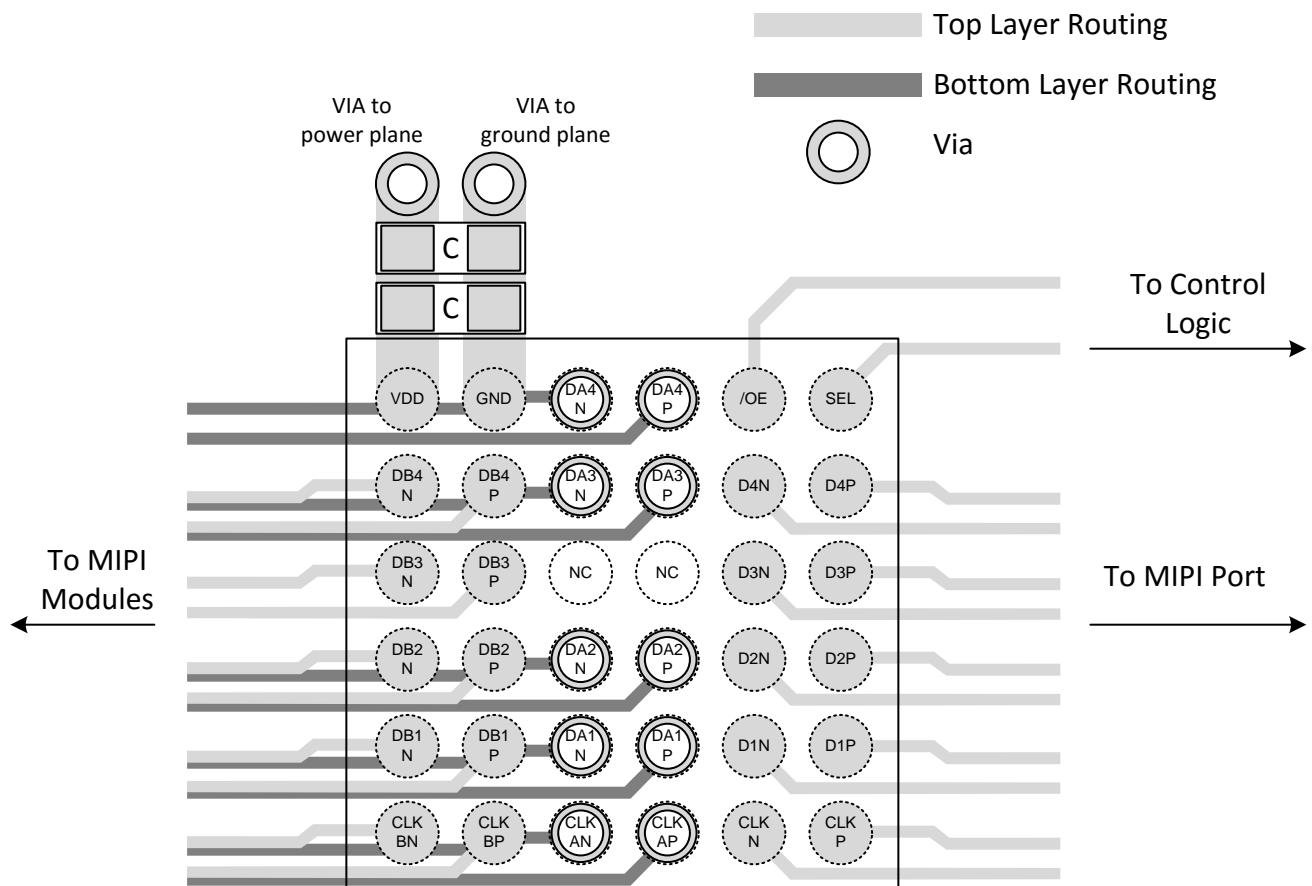

Figure 31. Layout Example

## 12 Device and Documentation Support

### 12.1 Documentation Support

### 12.2 Receiving Notification of Documentation Updates

To receive notification of documentation updates, navigate to the device product folder on ti.com. In the upper right corner, click on *Alert me* to register and receive a weekly digest of any product information that has changed. For change details, review the revision history included in any revised document.

### 12.3 Community Resources

The following links connect to TI community resources. Linked contents are provided "AS IS" by the respective contributors. They do not constitute TI specifications and do not necessarily reflect TI's views; see TI's [Terms of Use](#).

**TI E2E™ Online Community** *TI's Engineer-to-Engineer (E2E) Community*. Created to foster collaboration among engineers. At e2e.ti.com, you can ask questions, share knowledge, explore ideas and help solve problems with fellow engineers.

**Design Support** *TI's Design Support* Quickly find helpful E2E forums along with design support tools and contact information for technical support.

### 12.4 Trademarks

E2E is a trademark of Texas Instruments.  
All other trademarks are the property of their respective owners.

### 12.5 Electrostatic Discharge Caution



This integrated circuit can be damaged by ESD. Texas Instruments recommends that all integrated circuits be handled with appropriate precautions. Failure to observe proper handling and installation procedures can cause damage.

ESD damage can range from subtle performance degradation to complete device failure. Precision integrated circuits may be more susceptible to damage because very small parametric changes could cause the device not to meet its published specifications.

### 12.6 Glossary

**SLYZ022** — *TI Glossary*.

This glossary lists and explains terms, acronyms, and definitions.

## 13 Mechanical, Packaging, and Orderable Information

The following pages include mechanical, packaging, and orderable information. This information is the most current data available for the designated devices. This data is subject to change without notice and revision of this document. For browser-based versions of this data sheet, refer to the left-hand navigation.

## PACKAGING INFORMATION

Orderable Device	Status (1)	Package Type	Package Drawing	Pins	Package Qty	Eco Plan (2)	Lead finish/ Ball material (6)	MSL Peak Temp (3)	Op Temp (°C)	Device Marking (4/5)	Samples
TS5MP646YFPR	NRND	DSBGA	YFP	36	3000	RoHS & Green	SNAGCU	Level-1-260C-UNLIM	-40 to 85	TS5MP646	

(1) The marketing status values are defined as follows:

**ACTIVE:** Product device recommended for new designs.

**LIFEBUY:** TI has announced that the device will be discontinued, and a lifetime-buy period is in effect.

**NRND:** Not recommended for new designs. Device is in production to support existing customers, but TI does not recommend using this part in a new design.

**PREVIEW:** Device has been announced but is not in production. Samples may or may not be available.

**OBSOLETE:** TI has discontinued the production of the device.

(2) **RoHS:** TI defines "RoHS" to mean semiconductor products that are compliant with the current EU RoHS requirements for all 10 RoHS substances, including the requirement that RoHS substance do not exceed 0.1% by weight in homogeneous materials. Where designed to be soldered at high temperatures, "RoHS" products are suitable for use in specified lead-free processes. TI may reference these types of products as "Pb-Free".

**RoHS Exempt:** TI defines "RoHS Exempt" to mean products that contain lead but are compliant with EU RoHS pursuant to a specific EU RoHS exemption.

**Green:** TI defines "Green" to mean the content of Chlorine (Cl) and Bromine (Br) based flame retardants meet JS709B low halogen requirements of <=1000ppm threshold. Antimony trioxide based flame retardants must also meet the <=1000ppm threshold requirement.

(3) MSL, Peak Temp. - The Moisture Sensitivity Level rating according to the JEDEC industry standard classifications, and peak solder temperature.

(4) There may be additional marking, which relates to the logo, the lot trace code information, or the environmental category on the device.

(5) Multiple Device Markings will be inside parentheses. Only one Device Marking contained in parentheses and separated by a "-" will appear on a device. If a line is indented then it is a continuation of the previous line and the two combined represent the entire Device Marking for that device.

(6) Lead finish/Ball material - Orderable Devices may have multiple material finish options. Finish options are separated by a vertical ruled line. Lead finish/Ball material values may wrap to two lines if the finish value exceeds the maximum column width.

**Important Information and Disclaimer:**The information provided on this page represents TI's knowledge and belief as of the date that it is provided. TI bases its knowledge and belief on information provided by third parties, and makes no representation or warranty as to the accuracy of such information. Efforts are underway to better integrate information from third parties. TI has taken and continues to take reasonable steps to provide representative and accurate information but may not have conducted destructive testing or chemical analysis on incoming materials and chemicals. TI and TI suppliers consider certain information to be proprietary, and thus CAS numbers and other limited information may not be available for release.

In no event shall TI's liability arising out of such information exceed the total purchase price of the TI part(s) at issue in this document sold by TI to Customer on an annual basis.

**TAPE AND REEL INFORMATION**

**QUADRANT ASSIGNMENTS FOR PIN 1 ORIENTATION IN TAPE**

\*All dimensions are nominal

Device	Package Type	Package Drawing	Pins	SPQ	Reel Diameter (mm)	Reel Width W1 (mm)	A0 (mm)	B0 (mm)	K0 (mm)	P1 (mm)	W (mm)	Pin1 Quadrant
TS5MP646YFPR	DSBGA	YFP	36	3000	330.0	12.4	2.58	2.58	0.62	8.0	12.0	Q1

**TAPE AND REEL BOX DIMENSIONS**

\*All dimensions are nominal

Device	Package Type	Package Drawing	Pins	SPQ	Length (mm)	Width (mm)	Height (mm)
TS5MP646YFPR	DSBGA	YFP	36	3000	335.0	335.0	25.0



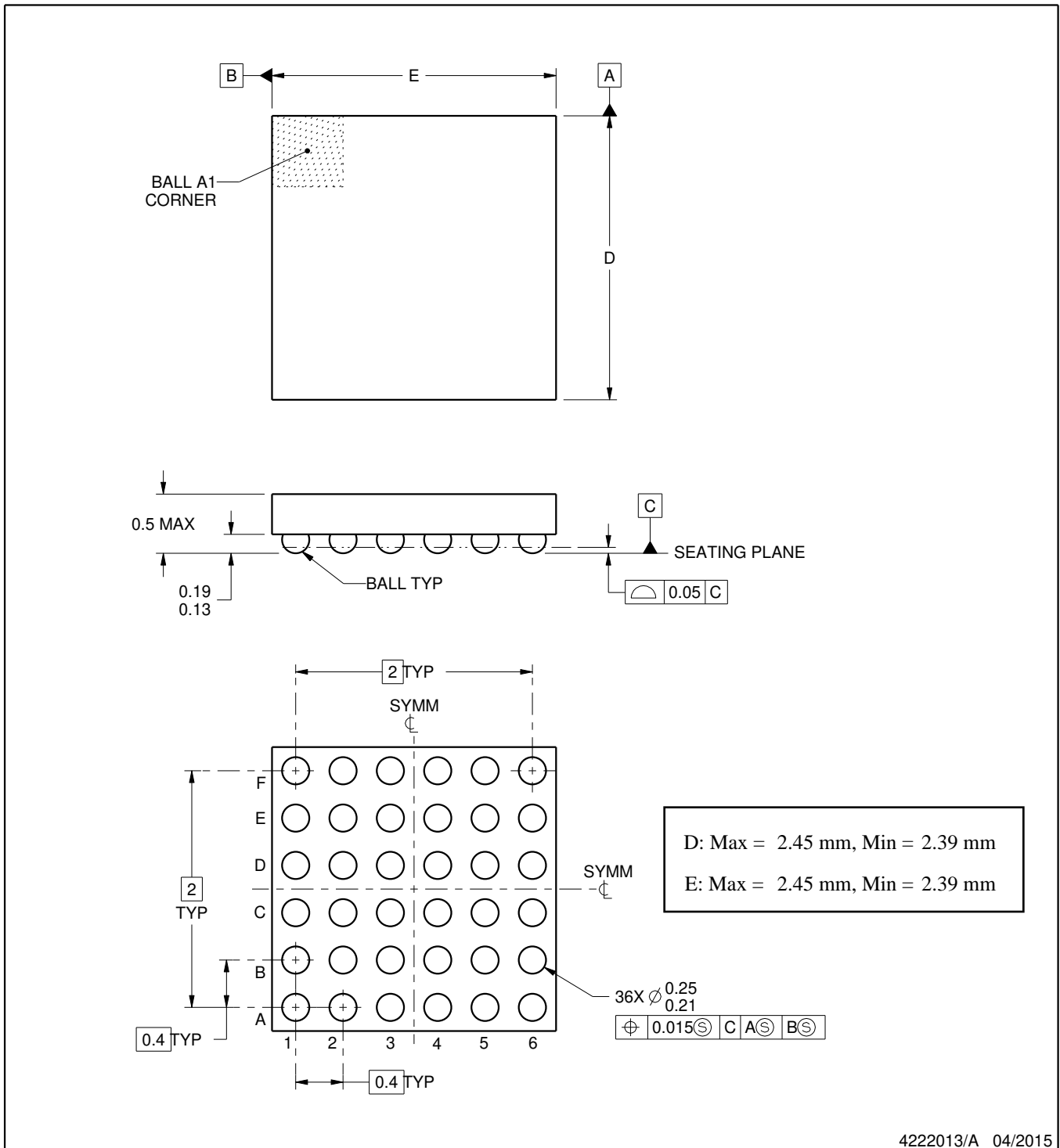
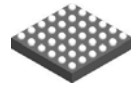

NOTES:

1. All linear dimensions are in millimeters. Any dimensions in parenthesis are for reference only. Dimensioning and tolerancing per ASME Y14.5M.
2. This drawing is subject to change without notice.

# EXAMPLE BOARD LAYOUT

YFP0036

DSBGA - 0.5 mm max height

DIE SIZE BALL GRID ARRAY

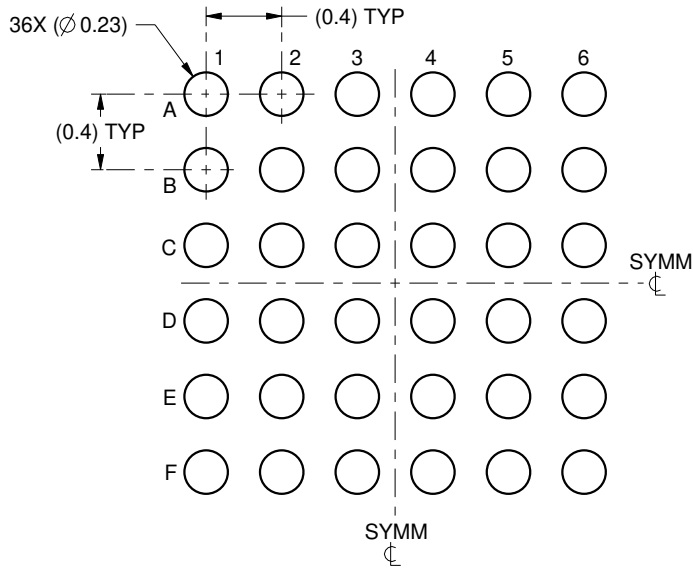

LAND PATTERN EXAMPLE  
SCALE:25X

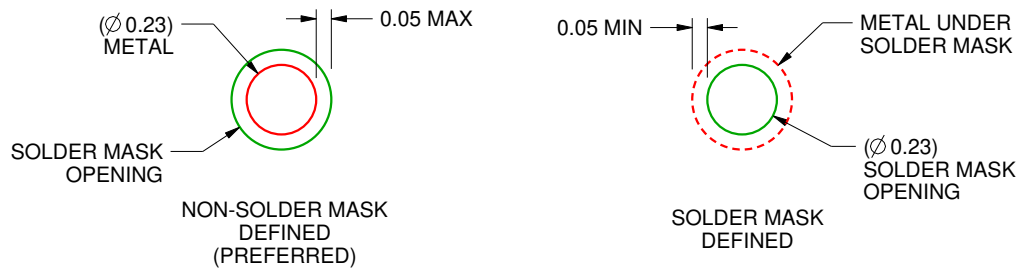

SOLDER MASK DETAILS  
NOT TO SCALE

4222013/A 04/2015

NOTES: (continued)

- Final dimensions may vary due to manufacturing tolerance considerations and also routing constraints. For more information, see Texas Instruments literature number SNVA009 ([www.ti.com/lit/snva009](http://www.ti.com/lit/snva009)).

# EXAMPLE STENCIL DESIGN

YFP0036

DSBGA - 0.5 mm max height

DIE SIZE BALL GRID ARRAY

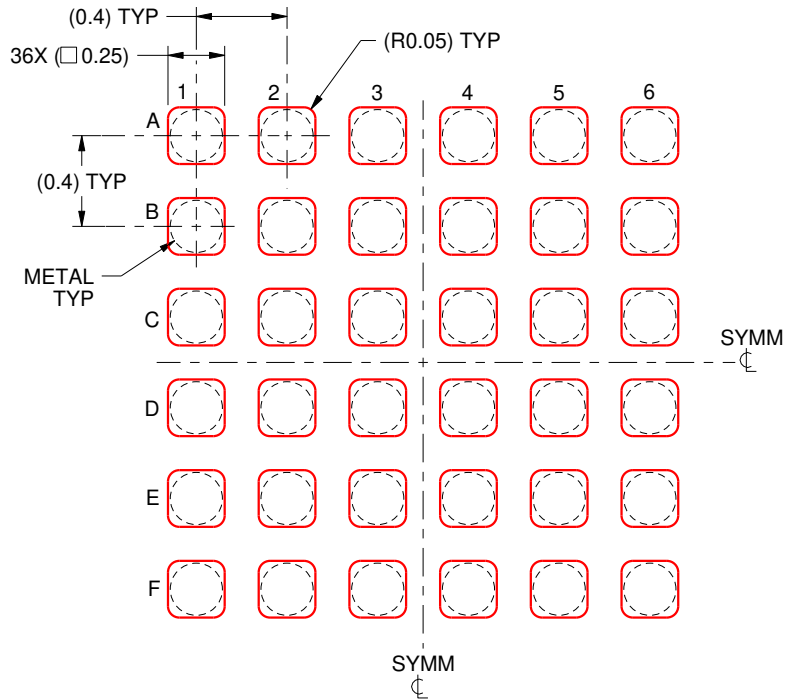

SOLDER PASTE EXAMPLE  
BASED ON 0.1 mm THICK STENCIL  
SCALE:30X

4222013/A 04/2015

NOTES: (continued)

4. Laser cutting apertures with trapezoidal walls and rounded corners may offer better paste release.

## IMPORTANT NOTICE AND DISCLAIMER

TI PROVIDES TECHNICAL AND RELIABILITY DATA (INCLUDING DATA SHEETS), DESIGN RESOURCES (INCLUDING REFERENCE DESIGNS), APPLICATION OR OTHER DESIGN ADVICE, WEB TOOLS, SAFETY INFORMATION, AND OTHER RESOURCES "AS IS" AND WITH ALL FAULTS, AND DISCLAIMS ALL WARRANTIES, EXPRESS AND IMPLIED, INCLUDING WITHOUT LIMITATION ANY IMPLIED WARRANTIES OF MERCHANTABILITY, FITNESS FOR A PARTICULAR PURPOSE OR NON-INFRINGEMENT OF THIRD PARTY INTELLECTUAL PROPERTY RIGHTS.

These resources are intended for skilled developers designing with TI products. You are solely responsible for (1) selecting the appropriate TI products for your application, (2) designing, validating and testing your application, and (3) ensuring your application meets applicable standards, and any other safety, security, regulatory or other requirements.

These resources are subject to change without notice. TI grants you permission to use these resources only for development of an application that uses the TI products described in the resource. Other reproduction and display of these resources is prohibited. No license is granted to any other TI intellectual property right or to any third party intellectual property right. TI disclaims responsibility for, and you will fully indemnify TI and its representatives against, any claims, damages, costs, losses, and liabilities arising out of your use of these resources.

TI's products are provided subject to [TI's Terms of Sale](#) or other applicable terms available either on [ti.com](https://www.ti.com) or provided in conjunction with such TI products. TI's provision of these resources does not expand or otherwise alter TI's applicable warranties or warranty disclaimers for TI products.

TI objects to and rejects any additional or different terms you may have proposed.

Mailing Address: Texas Instruments, Post Office Box 655303, Dallas, Texas 75265  
Copyright © 2023, Texas Instruments Incorporated