

REVISIONS					
P	LTR	DESCRIPTION	DATE	DWN	APVD
	R2	REVISED PER ECO-11-005027	11MAR11	RK	HMR
	R3	REVISED PER ECO-17-014338	10MAY2018	RS	DR

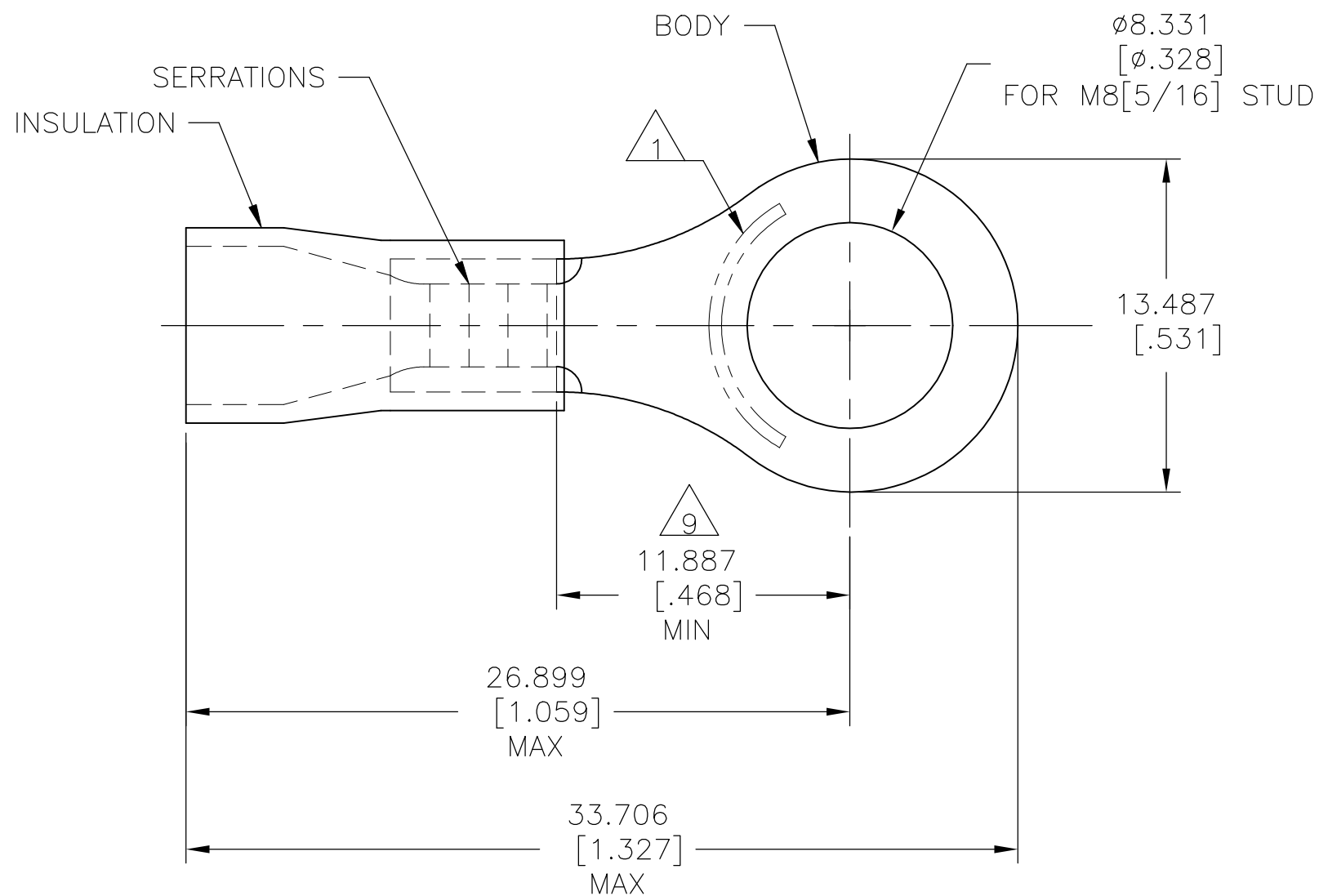

AMP WIRE RANGE	UL Listed	LR7189 Certified
12-10 AWG SOLID OR STRANDED	12-10 AWG SOLID OR STRANDED	12-10 AWG SOLID OR STRANDED

- 1 STAMP AMP 12-10*, APPROX AS SHOWN
- 2 WIRE INSULATION DIA: $\phi 3.810 - \phi 6.350 [\phi .150 - \phi .250]$
- 3 BODY MATERIAL THK IS $1.016 \pm 0.051 [.040 \pm .002]$
- 4 MATERIAL: BODY: COPPER PER ASTM B152
INSULATION: PVC
- 5 NOTE DELETED
- 6 NOTE DELETED
- 7 FINISH:
BODY: TIN PL. PER ASTM B545
INSULATION: COLOR- YELLOW
- 8 NOTE DELETED
- 9 APPLIES FROM CENTER OF STUD HOLE
TO EDGE OF METAL WIRE BARREL

50	LOOSE PIECE, BOX	8-34856-2
2500	ON TAPE, REEL	2-34856-1
500	LOOSE PIECE	34856
QTY	PACKAGE TYPE	PART NO

AMP INCORPORATED CUSTOMER SERVICE SYSTEMS		MAX RECOMMENDED OPERATING TEMPERATURE: 105°C [221°F]	THIS DRAWING IS A CONTROLLED DOCUMENT.		DWN DK SCHRUM 08/06/92	STE TE Connectivity Ltd.			
FOR ADDITIONAL PRODUCT INFORMATION OR COPIES OF DRAWINGS AND TECHNICAL DOCUMENTS	PRODUCT INFORMATION CENTER 1-800-522-6752	VOLTAGE RATING: N/A	DIMENSIONS: mm [INCHES]	TOLERANCES UNLESS OTHERWISE SPECIFIED:	CHK RE HERSEY 11/10/92				NAME M ELLIS
FOR APPLICATION TOOLING INFORMATION	TOOLING ASSISTANCE CENTER 1-800-722-1111	CIRCULAR MIL AREA: $2.62 - 6.64 \text{mm}^2 [5180 - 13100]$ SOLID OR STRANDED		0 PLC ± - 1 PLC ± - 2 PLC ± - 3 PLC ± 0.127[.005] 4 PLC ± - ± - ANGLES ± -	APVD M ELLIS 11/10/92	PRODUCT SPEC UL 486 A-B			
FOR ORDER ENTRY	1-800-526-5142	THIS DRAWING IS A CONTROLLED DOCUMENT FOR AMP INCORPORATED. IT IS SUBJECT TO CHANGE AND THE CONTROLLING ENGINEERING ORGANIZATION SHOULD BE CONTACTED FOR THE LATEST REVISION.	MATERIAL	FINISH	APPLICATION SPEC 114-2161	SIZE A3	CAGE CODE 00779	DRAWING NO C-34856	RESTRICTED TO -
					WEIGHT	CUSTOMER DRAWING			SCALE 4:1
								SHEET 1 OF 1	REV R3