

**High efficiency, ultra small size adjustable output type high voltage power supply**  
**High efficiency, I type resonance PWM formula 3.5W high voltage DC-DC converter**

**Bellnix®**

**0V to 350V PHV Series**

The PHV series was built using Bellnix's independent technology, the I type resonance PWM formula. With the use of I type resonance PWM formula, high efficiency (68% typ.) has been achieved with the high voltage power supply. As a result, the dimensions are 1/5 of the normal product size with the existing power of 3.5W. The PHV series is also using the 5 sided metallic shield case, and is expected to have high reliability and long life for an high voltage DC-DC converter with adjustable output voltage.



■ **Features**

- High efficiency 68%typ.
- High reliability
- Max output capacity 3.5W
- Low price/long life
- 5 sided metallic shield
- ON/OFF control (option)
- Adjustable voltage with external voltage
- Low ripple noise
- PCB mount type
- MTBF anticipated value 400,000H
- Over current protection
- Ultra small size

■ **Model name/Rating**

Model name PHV Series	Input voltage (Vdc)	Output voltage (Vdc)	Adjustable output voltage range (Vdc)(Note1)	Output current (mA)	Output capacity (W)	Input current (mA) typ	Ripple noise (mVp-p) typ	Case
<b>PHV12-350S10P</b>	10.8 to 16.5	+350	0 to +350	0 to 10	3.5	430	100	PH-15
<b>PHV12-350S10N</b>	10.8 to 16.5	-350	0 to -350	0 to 10	3.5	430	100	PH-15

■ **Specifications**

Line Regulation	0.01% typ.(Input voltage +12V± 1V)
Load Regulation	0.01% typ.(Load current varying from 0% to 100% )
Temp Regulation	± 0.01%/°C typ.(Temp varying from -10°C to +50°C)
Over current protection	Drooping type characteristic, auto restart circuit which operates at 105% or greater
Output voltage acc.	Below ± 5%(Rated output, rated load, Vcont=6V)
Output voltage control	External voltage 0V to +6V or an external resistor 5KΩ to adjust
ON/OFF control (note2)	Available (Between 2pin-5pin : When open, the output will turn on, when short, the output will turn off)
Usage temp range	-10°C to +50°C(Dearting required for temp +40°C and higher)
Storage temp range	-25°C to +85°C
Usage humidity range	20% to 95%RH(No dewing)
Isolation between input/output	Non-isolated type (2pin-6pin and case are internally connected)

Note1: The output voltage will be controlled by applying the Vcont voltage. Using an adjustable resistor or an external voltage, voltage should be applied on the Vcont pin in order to control the output voltage. When Vcont voltage=0V the output voltage (output residual voltage) should be less than 2.0% of the max output voltage.

Note2: The ON/OFF control is optional. When ordering, add a suffix "R" to the end of the product name. Ex) PHV12-350S10PR. (R=Remote control)

■ **Test circuit**

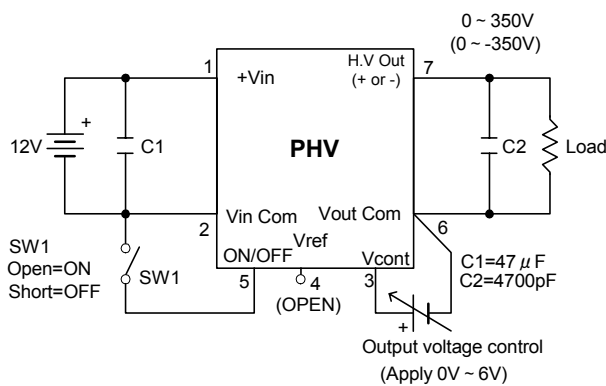

Warning 1: The input-output ground line and case are internally connected.

Warning 2: Vref is 6V±0.3V (When external VR=5KΩ)

Warning 3: The ON/OFF can be controlled with a transistor.

■ **Block diagram**

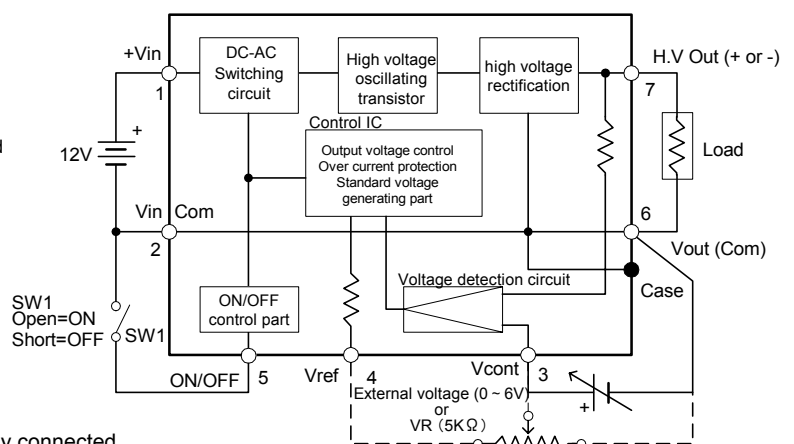

## Model/Dimensions/Pin configuration (PH-15 case)

Dimensions and pin configuration for standard products

Pin configuration with the optional ON/OFF control

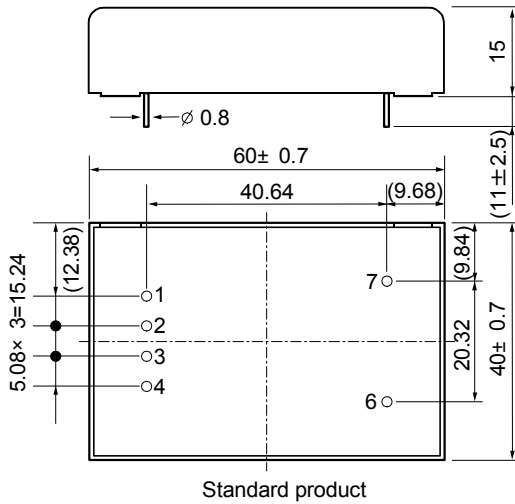

Standard product

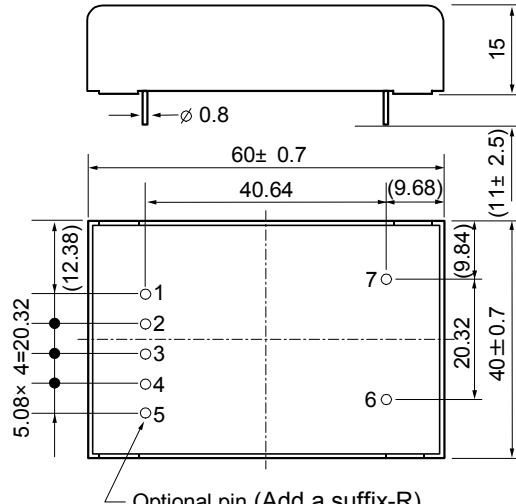

Optional pin (Add a suffix-R)

Pin	Function
1	+Vin
2	Vin Com
3	Vcont
4	Vref
5	ON/OFF
6	Vout Com
7	H.V Out (+ or -)

ON/OFF is optional

Weight : 72g typ.

Units : mm

Margin of error: ±0.5

## Controlling the output voltage using an adjustable resistor

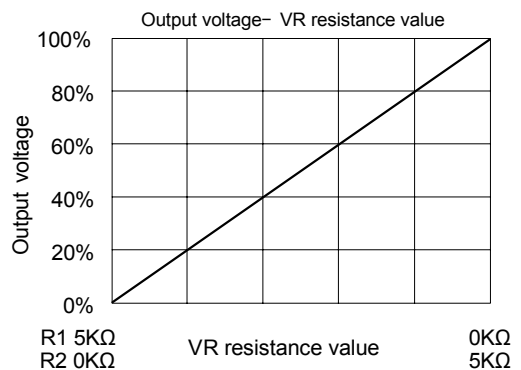
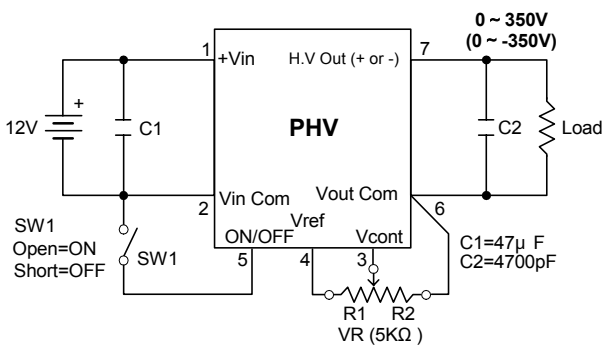

## Controlling the output voltage using an external voltage

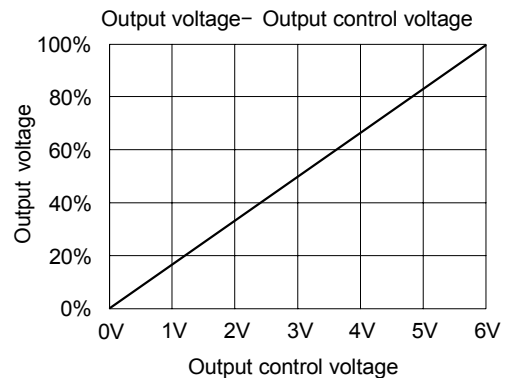
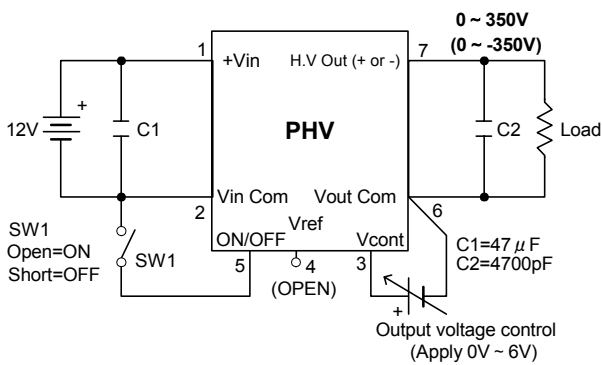

## Standard usage information

PHV series

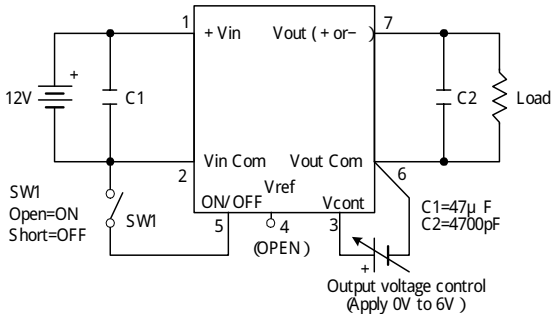

The PHV series does not require any external parts, however when the input impedance is high, for example: the distance between the power supply and converter is long, the input line is thin, or the input side has a filter then connecting a capacitor C1 to the input side is recommended. Place the capacitor as close as possible to the converter pin side, to lower the lead inductance.

## ON/OFF control (optional)

By opening and closing between the ON/OFF pin and Vin Com pin the output voltage can be externally turned on and off.

Between the ON/OFF pin (5) and -Vin pin (2)

- ① Open will turn the output ON
- ② Short (0 to 1.0V, 1mA max) will turn the output OFF

The ON/OFF pin is internally pulled up to the 5V, so be careful of the voltage from the switching element of the ON/OFF pin (photo couplers, transistors, etc) Keep open when not using the ON/OFF control.

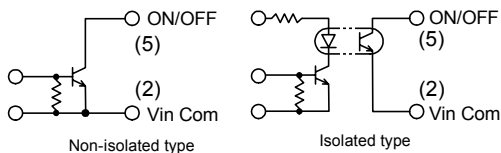

Since the chattering to the ON/OFF pin will affect the output voltage, choose one without any chattering. When the output is turned off by the ON/OFF control, the residual output voltage should be within 0.5%. (at Input/Output rating)

## Over current protection

The PHV series has a over load and load short protection installed. When the product status is in over load or load short mode, the output voltage will decrease, and once the problem has been removed, the voltage will automatically recover.

The PHV series Over current protection characteristic

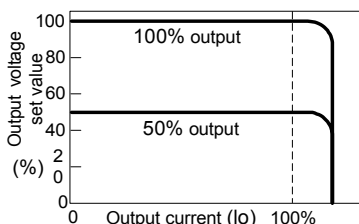

## Setting/Adjusting the output voltage

The PHV series output voltage can be set or adjusted using an external voltage or external adjustable resistor.

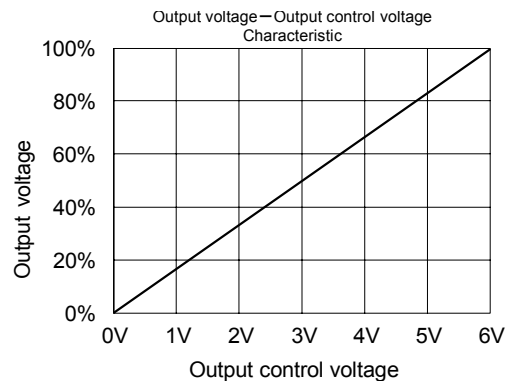
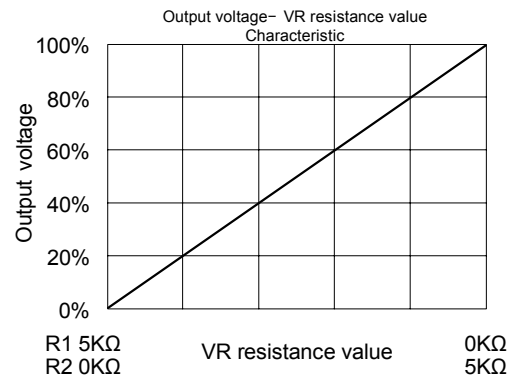
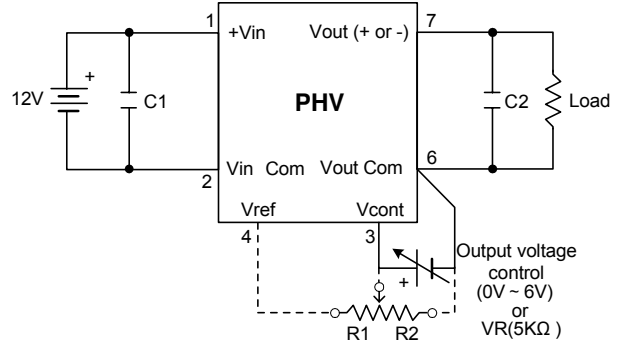

- The above characteristics (Output voltage -VR resistor value characteristic) graph is an indication of the resistance value R1 and R2. When setting the voltage to a set rate using a stable resistor, first decide the adjustable resistor R1 and R2.
- Do not apply voltage higher than 6V+5% on the Vcont.
- Use an adjustable resistor appliance with good temperature characteristics.
- When the resistance value is 5.0KΩ (R1=0Ω, R2=5KΩ), the max.voltage 6.0V will impress to Vcont pin. Therefore, the margin of error for the resistance value will largely affect the max output voltage, so use the resistance value as 5.0KΩ±5%.

## ■ Recommended pattern

① The PHV series uses a metallic case. When mounting to a double-sided PCB, the wiring for the converter should be on the soldering side.

Alt: Also, this converter will generate high voltages so the creepage distance should also be taken in when designing.

② When mounting to a double-sided PCB, the land of the parts side of the high voltage output pin should

③ The metallic case does not need to be connected to ground. However, when using and grounded with the metallic case, make the impedance lower as possible between the ground.

## ■ Vref pin (Standard voltage output)

When controlling the output voltage with an adjustable resistor, this pin is used. Vref has a standard output voltage of 6V. In this case, the external adjustable resistor is 5KΩ. Since the resistance value from the external adjustable resistor will decide the output voltage with the effect of the specified value, use a resistance value with an accuracy of 5KΩ±5%. The type of resistor does not matter, as long as it is 5KΩ, however one with a good temp coefficient is recommended.

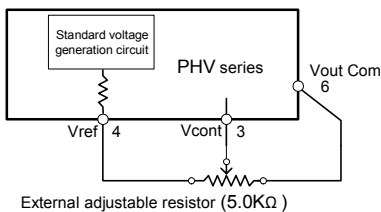

## ■ Prevention of inverse input connection

The converter may break if the polarities are reversed. If there is a possibility in which the connections may be reversed, connect a diode and fuse like below.

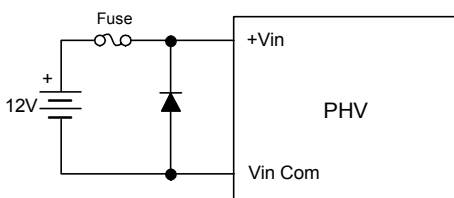

## ■ Recommended soldering conditions

Soldering conditions for each part are as follows:

- |                          |              |         |
|--------------------------|--------------|---------|
| ① Using a soldering iron | 340 to 360°C | 5 sec.  |
| ② Using a soldering tub  | 230 to 260°C | 10 sec. |

## ■ Lowering the output noise even farther

The PHV series output voltage can be adjusted by using an external voltage or external adjustable resistor.

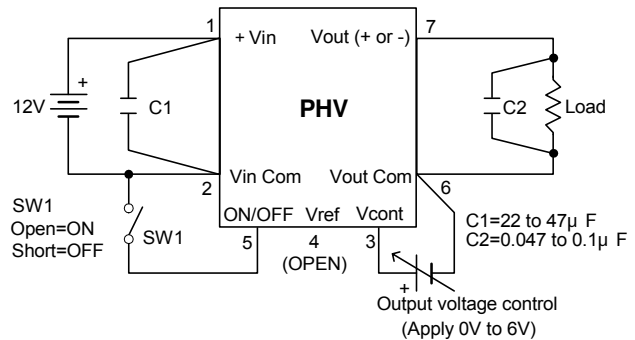

When lowering the output noise, the wiring of the input and output should be as short as possible. Place C2 closest to the load, paying attention to creepage and clearance distances.

### Point!

- ① Choose a capacitor with a high-frequency when adding to the input.
- ② Earth (COMMON) line should be thick and short in the pattern design to lower the common impedance.
- ③ The capacitor which is connected to the output side should be able to withstand the pressure, when connected to the load side. At this time, the capacitor lead should be shortened. Also when the load response time is a problem, please be aware of the time constant.

## ■ Guarantee

This product shall be guaranteed for a year. During this period, if there should be any failure definitely due to our designing or manufacturing, we will repair or replace it with a new one at our expense. However, in any case that the product is modified and/or has made any internal remodeling by the buyer, the product can no longer be guaranteed. This guarantee shall cover only the PHV series.

- If you have any further technical questions for this product, please contact to us.

E-mail: [info@bellnix.com](mailto:info@bellnix.com)  
<http://www.bellnix.com>