

ATAB663211A Development Board

ATAN0111

Introduction

The development board for the Atmel® ATA663211 is designed to give users a quick start using these ICs and prototyping and testing new designs. The Atmel ATA663211 is a fully integrated LIN transceiver complying with the LIN 2.0, 2.1, 2.2, 2.2A specification and SAEJ2602-2.

The IC is the interface between the LIN protocol handler and the physical layer and is designed to handle the low-speed data communication in vehicles for example in convenience electronics. Improved slope control on the LIN bus ensures secure data communication of up to 20kBaud.

This document has been created as a quick start guide for using the development board of the Atmel ATA663211. Please refer to the corresponding datasheet for more detailed information about the Atmel ATA663211 itself.

Figure 1. Atmel ATAB663211A Development Board

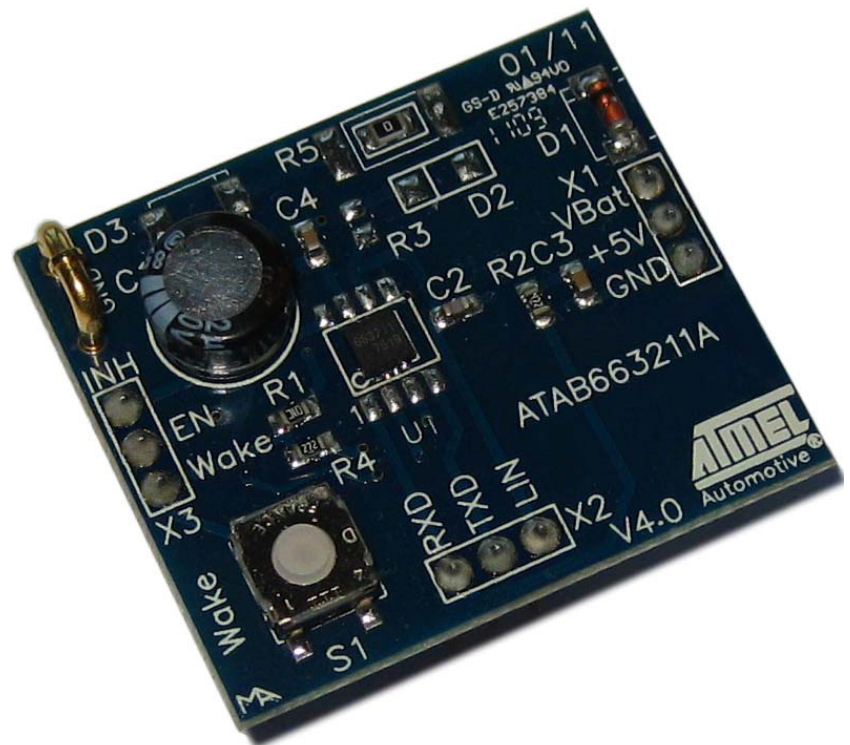

Development Board Features

The development board for the Atmel® ATA663211 supports the following features:

- Includes All Components Necessary for Atmel ATA663211 Operation
- All Pins Are Easily Accessible
- Can Be Used for Master or Slave Operation
- Wake-up Pulse via an On-board Switch
- Dual footprint for both available packages: DFN8 and SO8

Quick Start

The development board for the Atmel ATA663211 is shipped with all components necessary to immediately start the development of a LIN slave node.

Connecting an external 12V DC power supply between the terminals VBAT and GND puts the IC in fail-safe mode. In this mode, the INH pin is switched to the VS level which can be used to enable an external voltage regulator (not included on the board). The LIN pin is in the recessive state.

Please note that the communication is still inactive during fail-safe mode.

To communicate via the LIN bus interface, you have to switch the device into normal mode by applying a high level (for example 5V) at pin EN.

As RXD is an open-drain output, the required pull-up resistor R2 can be activated by applying +5V DC voltage, on the designated pin on the board.

1. Hardware Description

In the following sections only the normal operating conditions are described. Refer to the corresponding datasheet for detailed information about the features mentioned.

1.1 Power Supply (VBAT, +5V and GND)

The development board requires an external 5.7V to 27V DC power supply between the terminals VBAT and GND. The input circuit is protected against inverse polarity with the protection diode D1, resulting in a difference between the VBAT and VS level of approximately 0.7V.

The DC voltage at pin +5V is only required for activating the pull-up resistor for the pin RXD.

1.2 LIN Interface (LIN, TXD and RXD)

1.2.1 Bus Pin (LIN)

A low-side driver with internal current limitation, thermal shutdown, and an internal pull-up resistor in compliance with LIN spec 2.x is implemented. The internal pull-up resistor is active in normal and fail-safe mode. The LIN receiver thresholds are compatible with the LIN protocol specification. The reverse current from the LIN bus to Vs is $<2\mu\text{A}$, even when Vbat is disconnected.

At a short circuit between LIN and V_{Battery} , the output limits the output current. Due to the power dissipation, the chip temperature exceeds the overtemperature threshold and the LIN output is switched off. The chip cools down and after the temperature hysteresis the output switches on again. RXD stays high because LIN is high.

On the board the LIN pin is assembled with a 220-pF capacitor to ground. Additionally, the two extra components diode D2 (LL4148) in series with resistor R3 ($1\text{k}\Omega$) required for using the development board for a LIN master application have designated placeholders for convenient mounting.

1.2.2 Input/Output Pin (TXD)

In normal mode the TXD pin is the microcontroller interface for controlling the state of the LIN output. TXD must be pulled to ground in order to drive the LIN bus low. If TXD is high, the LIN output transistor is turned off and the bus is in the recessive state. If the TXD pin stays at GND level while switching into normal mode, it must be pulled to high level longer than $10\mu\text{s}$ before the LIN driver can be activated. This feature prevents the bus line from being accidentally driven to dominant state after normal mode has been activated (also in case of a short circuit at TXD to GND). During fail-safe mode, this pin is used as output and signals the fail-safe source.

The TXD pin provides a pull-down resistor in order to have a defined level if TXD is disconnected. An internal timer prevents the bus line from being driven permanently in the dominant state. If TXD is forced to low longer than $t_{\text{dom}} > 20\text{ms}$, the LIN bus driver is switched to the recessive state. Nevertheless, when switching to sleep mode, the actual level at the TXD pin is relevant. To reactivate the LIN bus driver, switch TXD to high ($> 10\mu\text{s}$).

1.2.3 Output Pin (RXD)

This pin reports the state of the LIN bus to the microcontroller. LIN high (recessive state) is indicated by a high level at RXD, LIN low (dominant state) is indicated by a low level at RXD. The output is an open drain, therefore it is compatible with a 3.3V or 5V power supply. The output is short circuit protected.

Please note that the ATA663211 has to be in normal mode in order to have the communication via LIN enabled.

After a wake-up the device is in fail-safe mode and the RXD pin switches to low in order to interrupt the microcontroller.

1.3 System Control (EN, INH and WKin)

1.3.1 Enable Input Pin (EN)

This pin controls the operating mode of the interface. If EN = 1, the interface is in normal mode with transmission paths from TXD to LIN and from LIN to RXD both active. After a falling edge on EN while TXD is set to high, the device switches to sleep mode, no transmission is possible anymore, and the LIN pin is pulled to VS by a weak current source.

During sleep mode the device is still supplied from the battery voltage with the supply current of typically 9µA. The EN pin provides a pull-down resistor to force the transceiver into recessive mode if EN is disconnected.

1.3.2 Inhibit Output Pin (INH)

This pin is a high-side switch to VS and it is intended to be used to control an external voltage regulator or to switch the LIN master pull-up resistor on/off in case the device is used in a master node (see [Figure 1-1](#)). The output transistor is protected by internal temperature monitoring. If the device is in normal or in fail-safe mode, the inhibit high-side switch is turned on, in sleep mode it is turned off.

Figure 1-1. Switching the LIN Master Pull-up Resistor by the INH Output

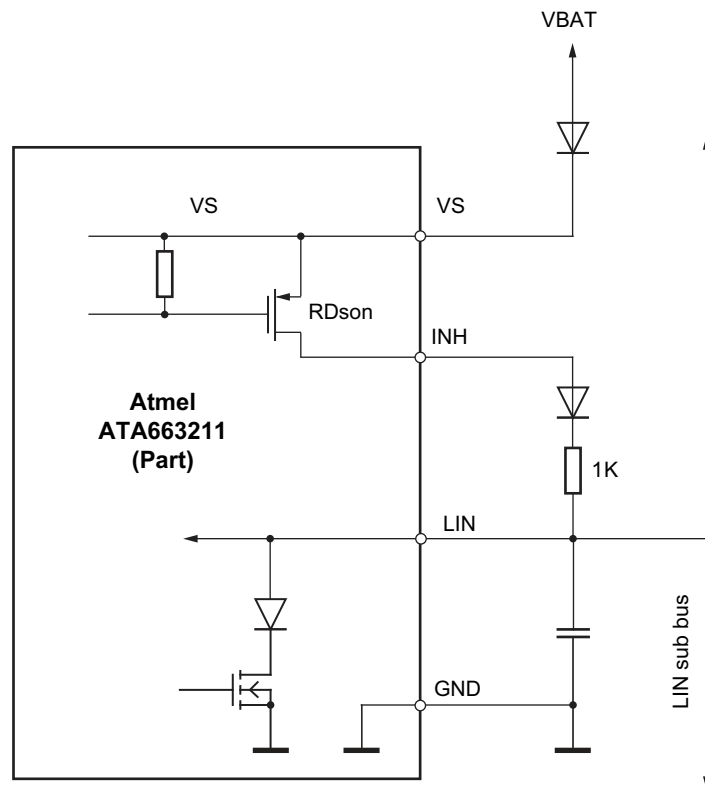

With this measure the current consumption in the case of a short circuit between LIN and GND can be reduced to a minimum, because the Atmel ATA663211 can be switched into sleep mode and therefore the INH output is off.

A wake-up event on the LIN bus (remote wake-up) or at the pin WKin (local wake-up) switches the IC into fail-safe mode and therefore the INH output is on. The same happens after a system power-up.

1.3.3 WAKE Input Pin (WKin)

This pin is a high voltage input used to wake up the device from sleep mode. It is usually connected to an external switch in order to generate a local wake-up. A pull-up current source with typically $-10\mu\text{A}$ is implemented as well as a debounce timer. On the development board there is the push button S1 to generate a local wake-up by pulling the WKin pin to GND. The resistor $R4 = 2.7\text{k}\Omega$ is needed to limit the input current in the case of voltage transients.

Even if the WKin pin is pulled to GND, it is possible to switch the IC into sleep mode.

If no local wake-up is required for the application, the WKin pin can be connected directly to the VS pin.

2. Schematic and Layout of the Atmel ATAB663211A Development Board

Figure 2-1. Schematic of the ATAB663211A Development Board

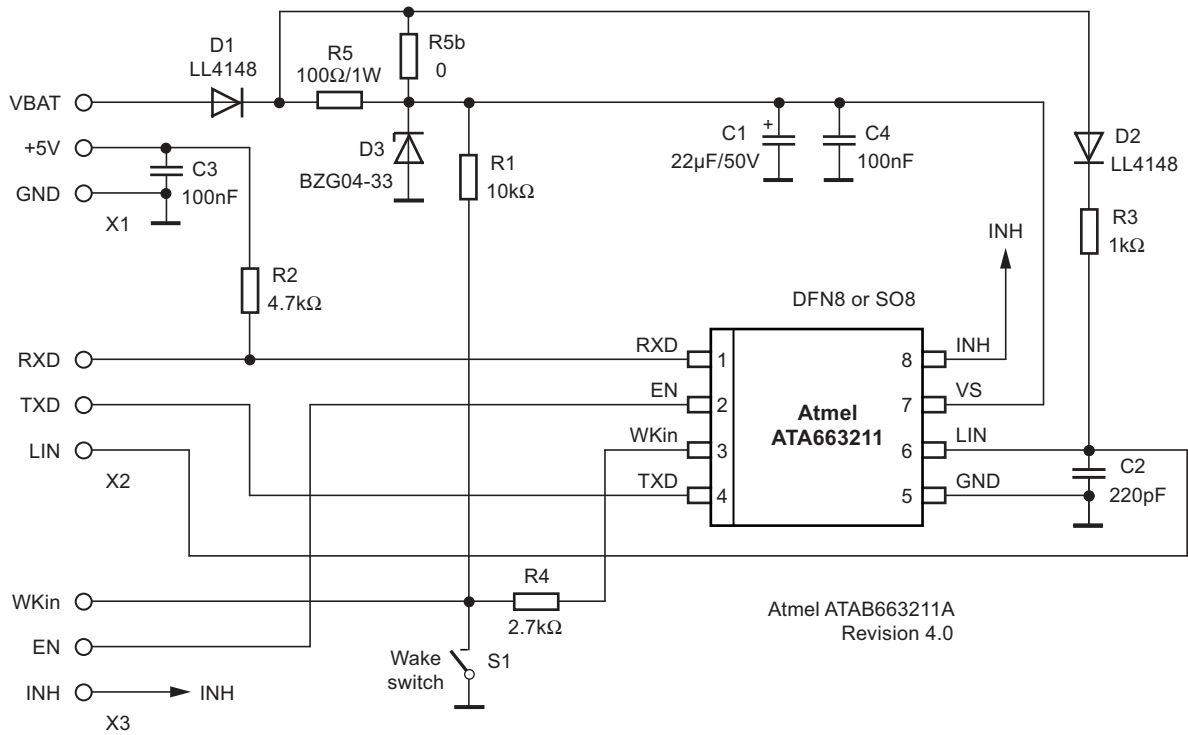

- Notes:
1. D2 and R3 are only required for a master node.
 2. R5 and D3 are not used, R5b is 0Ω.

Figure 2-2. Atmel ATAB663211A Development Board Component Placement; Top Side, Top View

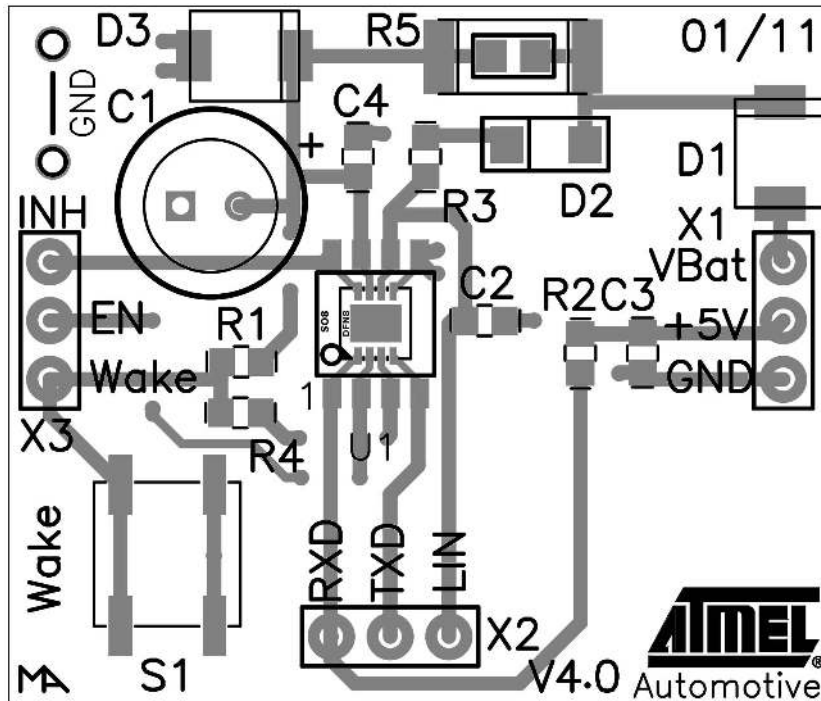

Figure 2-3. Atmel ATAB663211A Development Board; Top Side, Top View

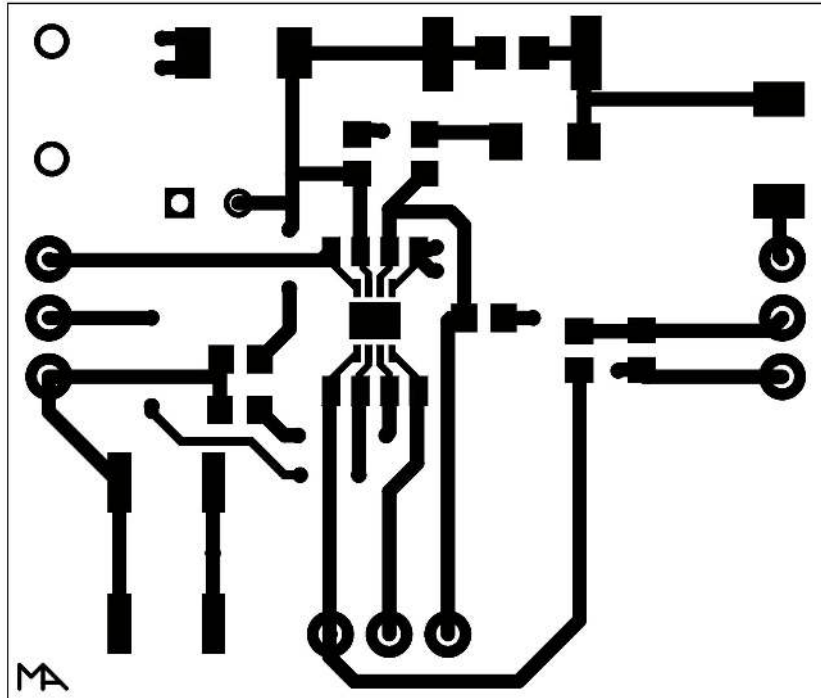
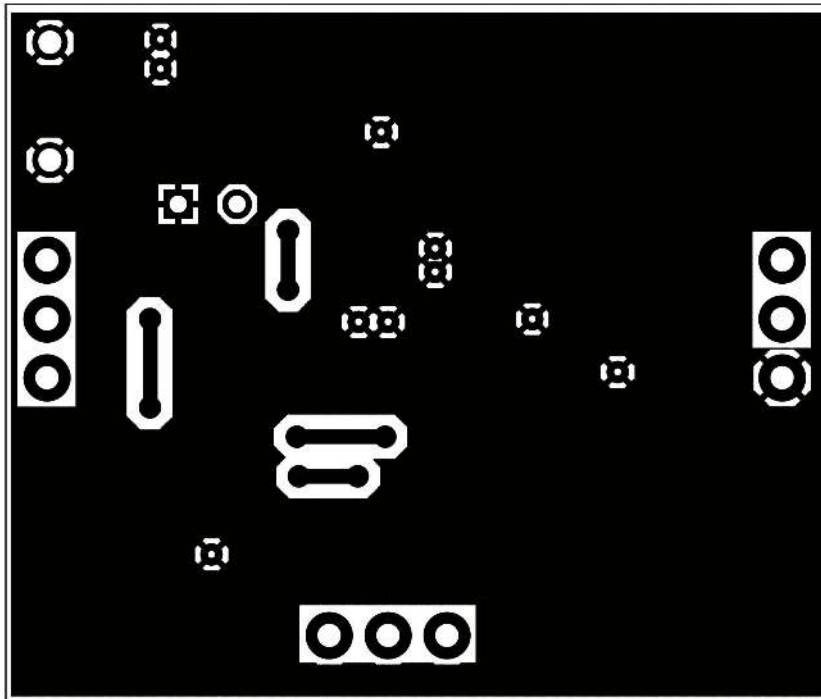

Figure 2-4. Atmel ATAB663211A Development Board; Bottom Side, Top View (Transparent PCB View)





Atmel Corporation 1600 Technology Drive, San Jose, CA 95110 USA T: (+1)(408) 441.0311 F: (+1)(408) 436.4200 | www.atmel.com

© 2014 Atmel Corporation. / Rev.: Rev.: 9363A–AUTO–10/14

Atmel®, Atmel logo and combinations thereof, Enabling Unlimited Possibilities®, and others are registered trademarks or trademarks of Atmel Corporation in U.S. and other countries. Other terms and product names may be trademarks of others.

DISCLAIMER: The information in this document is provided in connection with Atmel products. No license, express or implied, by estoppel or otherwise, to any intellectual property right is granted by this document or in connection with the sale of Atmel products. EXCEPT AS SET FORTH IN THE ATMEL TERMS AND CONDITIONS OF SALES LOCATED ON THE ATMEL WEBSITE, ATMEL ASSUMES NO LIABILITY WHATSOEVER AND DISCLAIMS ANY EXPRESS, IMPLIED OR STATUTORY WARRANTY RELATING TO ITS PRODUCTS INCLUDING, BUT NOT LIMITED TO, THE IMPLIED WARRANTY OF MERCHANTABILITY, FITNESS FOR A PARTICULAR PURPOSE, OR NON-INFRINGEMENT. IN NO EVENT SHALL ATMEL BE LIABLE FOR ANY DIRECT, INDIRECT, CONSEQUENTIAL, PUNITIVE, SPECIAL OR INCIDENTAL DAMAGES (INCLUDING, WITHOUT LIMITATION, DAMAGES FOR LOSS AND PROFITS, BUSINESS INTERRUPTION, OR LOSS OF INFORMATION) ARISING OUT OF THE USE OR INABILITY TO USE THIS DOCUMENT, EVEN IF ATMEL HAS BEEN ADVISED OF THE POSSIBILITY OF SUCH DAMAGES. Atmel makes no representations or warranties with respect to the accuracy or completeness of the contents of this document and reserves the right to make changes to specifications and products descriptions at any time without notice. Atmel does not make any commitment to update the information contained herein. Unless specifically provided otherwise, Atmel products are not suitable for, and shall not be used in, automotive applications. Atmel products are not intended, authorized, or warranted for use as components in applications intended to support or sustain life.

SAFETY-CRITICAL, MILITARY, AND AUTOMOTIVE APPLICATIONS DISCLAIMER: Atmel products are not designed for and will not be used in connection with any applications where the failure of such products would reasonably be expected to result in significant personal injury or death ("Safety-Critical Applications") without an Atmel officer's specific written consent. Safety-Critical Applications include, without limitation, life support devices and systems, equipment or systems for the operation of nuclear facilities and weapons systems. Atmel products are not designed nor intended for use in military or aerospace applications or environments unless specifically designated by Atmel as military-grade. Atmel products are not designed nor intended for use in automotive applications unless specifically designated by Atmel as automotive-grade.