

33194-0004 (W/D CPA VERSIDNO)
SCALE 21

ITEM #	QTY	MOLEX PN	REV LEVEL	REF/CHRYSLER PN	DESCRIPTION	MATERIAL
1	1	33194-0001	E	4793194	HOUSING	15% GLASS FILLED NYLON
2	1	33289-0001	B	4793198	GROMMET CAP	15% GLASS FILLED NYLON
3	1	33019-0023	D	4793197	GROMMET	SILICONE_30 DURED (BRANKE)
4	1	33288-0001	C	4793195	INSERT	15% GLASS FILLED NYLON
5	1	33019-1021	D	4793196	SEAL-PERIMETER	SILICONE_30 DURED (BLUE)

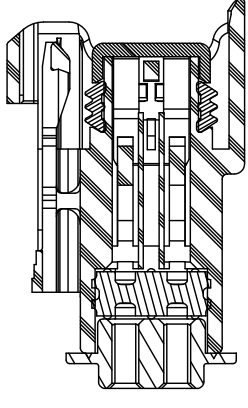

SECTION SIMILAR TO A-A
33194-0004 (W/D CPA VERSIDNO)
SCALE 41

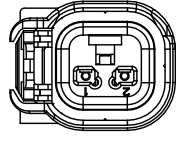

VIEW SHOWING 33197-0002

ITEM #	QTY	MOLEX PN	REV LEVEL	REF/CHRYSLER PN	DESCRIPTION	MATERIAL
1	1	33197-0001	-	4794005	HOUSING	15% GLASS FILLED NYLON
2	1	33289-0001	D	4793198	GROMMET CAP	15% GLASS FILLED NYLON
3	1	33019-0023	B	4793197	GROMMET	SILICONE_30 DURED (BRANKE)
4	1	33288-0001	C	4793195	INSERT	15% GLASS FILLED NYLON
5	1	33019-1021	D	4793196	SEAL-PERIMETER	SILICONE_30 DURED (BLUE)

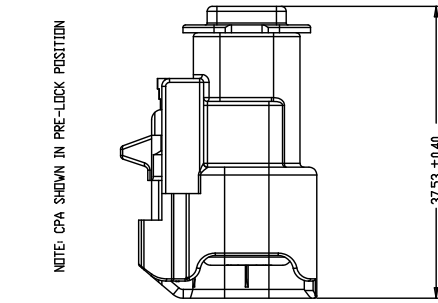

NOTE: CPA SHOWN IN PRE-LOCK POSITION

37.53 ±0.40

ITEM #	QTY	MOLEX PN	REV LEVEL	REF/CHRYSLER PN	DESCRIPTION	MATERIAL
1	1	33194-0001	E	4793194	HOUSING	15% GLASS FILLED NYLON
2	1	33289-0001	B	4793198	GROMMET CAP	15% GLASS FILLED NYLON
3	1	33019-0023	B	4793197	GROMMET	SILICONE_30 DURED (BRANKE)
4	1	33288-0001	C	4793195	INSERT	15% GLASS FILLED NYLON
5	1	33019-1021	D	4793196	SEAL-PERIMETER	SILICONE_30 DURED (BLUE)
6	1	33289-0001	F	4793199	CPA	NYLON_6/6 (RED)

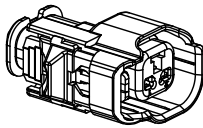

SCALE 21
33194-0002

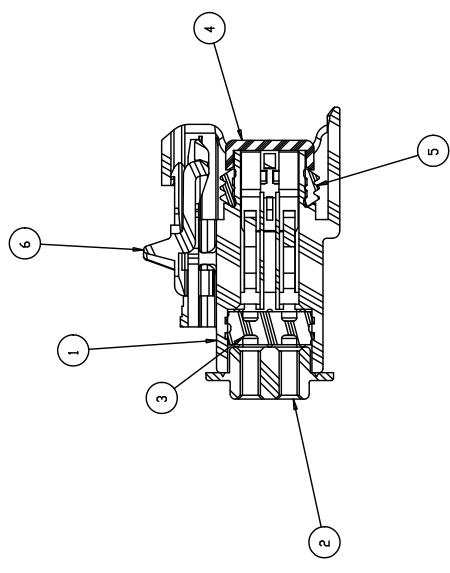

SECTION A-A
INSERT SHOWN IN FINAL-LOCK POSITION

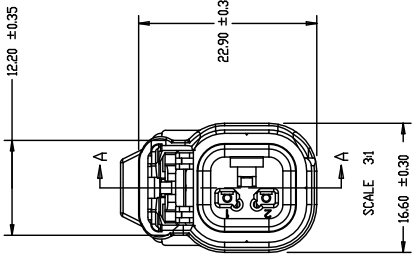

12.20 ±0.35

22.90 ±0.35

SCALE 31

16.60 ±0.30

VIEW SHOWING 33194-0002 AND 33194-0004

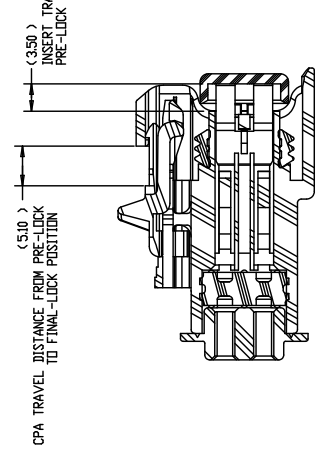

SECTION A-A
SCALE 31

CPA TRAVEL DISTANCE FROM PRE-LOCK POSITION TO FINAL-LOCK POSITION

(5.10)

INSERT TRAVEL DISTANCE FROM PRE-LOCK INTO FINAL-LOCK POSITION

(3.50)

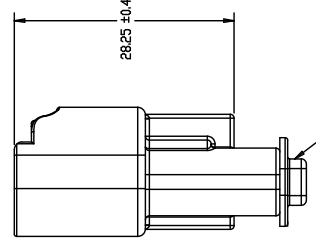

SCALE 51

28.25 ±0.40

OPTIONAL CONSTRUCTION FOR GROMMET CAP NOTCH LOCATION

GROMMET CAP TO BE CIRCULARLY WELDED TO THE CONNECTOR HOUSING. EXCESS FLASH IN WELD AREA PERMISSIBLE. GROMMET CAP TO MEET OR EXCEED 130 NEWTONS OF PULL-OFF FORCE.

NOTES: UNLESS OTHERWISE SPECIFIED

- SEE EMCAP DIRECT CONNECT INTERFACE DRAWING 150-S-002-1-201 (REF CHRYSLER DRAWING # 479375D) FOR COMPONENT DEVICE INTERFACE PRINT INFORMATION AND PART NUMBERS.
- REFER TO ASSEMBLY SET-UP SHEETS FOR DETAILED COMPONENT INFORMATION.
- FORCE TO PUSH INSERT INTO FINAL-LOCK POSITION SHOULD BE: 10 N TO 50 N OF FORCE.
- MINIMUM FORCE TO TAKE INSERT FROM FINAL-LOCK TO PRE-LOCK IS 27 N OF FORCE.
- MINIMUM FORCE TO REMOVE INSERT FROM CONNECTOR ONCE IN PRE-LOCK IS 20 N OF FORCE.
- MOLEX INSPECTION DEPARTMENT AND CUSTOMER WILL RECEIVE ASSEMBLY WITH INSERT IN PRE-LOCK POSITION AND CPA IN PRE-LOCK POSITION ON 331940002. (SEE SECTION A-A)
- REF. CONFORMS TO FOLLOWING CHRYSLER SPECIFICATIONS: CHRYSLER PF-9600 (A) (CLASS 3)
MS-1B414
MS-A130
MS-1044
MS-8888
MS-9502
- THE MAXIMUM INSERTION FORCE FOR A 16 AWG TO 20 AWG TERMINAL < 30N (EXCEPTION OF PF-9600 CHANGE A SECTION 53.12)
- SYSTEM TO BE USED WITH MS-8888 AND MS9902 CABLE SIZE 20, 18,16 AWG FOR SEALING PURPOSES ONLY
- SEE MOLEX DRAWING SD-3319-001 FOR TERMINAL USE

QUALITY SYMBOL COUNT	PERFORMANCE	ASSEMBLY	CUSTOMER
▽ = 0	▽ = 0	▽ = 0	▽ = 5

REV	DESCRIPTION
1	DISAPPEAR P/N REMOVED EC NO: UAU2011-0759 DRW: LDKESH SG CHK: T HERFURTH APP: V KOSHY

QUALITY SYMBOLS	GENERAL TOLERANCES (UNLESS SPECIFIED)
-0	4 PLACES ±
-0	3 PLACES ±
	2 PLACES ± 0.10
	1 PLACE ± 0.25
	ANGULAR ± 3°

SCALE	DESIGN UNITS	THIRD ANGLE PROJECTION	REVISE ON CAD ONLY
3:1	MM		

TITLE	RECEPTACLE CONNECTOR ASSY-2WAY 1.5MM BLADE SYSTEM, BRIDGED
DRAWN BY	T. HERFURTH
DATE	011602
CHECKED BY	A. BUTCHER
DATE	011602
APPROVED BY	T. HERFURTH
DATE	011602

MATERIAL NO.	DOCUMENT NO.	SHEET NO.
33194-0004	SD-33194-002	1 OF 1

MOLEX PART NUMBER	REFERENCE IIC PART NUMBER	PCL
33194-0002	04793200	H
33197-0002	04760751	M
33194-0004	NA	N

THIS DRAWING CONTAINS INFORMATION THAT IS PROPRIETARY TO MOLEX INCORPORATED AND SHOULD NOT BE USED WITHOUT WRITTEN PERMISSION

MOLEX INSPECTION DEPARTMENTS WILL RECEIVE ASSEMBLIES IN PRE-LOCK POSITION AS SHOWN