

# IsoBlock I-ZF

Single-Channel Zero Flux High Performance Current Sensor

## OVERVIEW

The IsoBlock I-ZF is a single channel module designed for high-quality high current measurements in the range from 20 to 2000 Amperes.

The IsoBlock I-ZF is a combination of two units: (1) sense the current flowing through a conductor and (2) condition the signal into a standard  $\pm 10V$ .

The sensing unit uses Hall Effect with closed loop methodology to measure the current flowing in the conductor passing through the aperture. This is followed by translation, corrections, scaling and anti-aliasing filter in the conditioning unit.

The compact form factor of the IsoBlock I-ZF module set allows users to setup high channel density monitoring systems, making it ideal for high performance compact systems.



## SPECIFICATION

IsoBlock I-ZF	20A	50A	100A	200A	300A	500A	600A	1000A	2000A
Bandwidth (-3dB point)	DC - 100kHz					DC-80kHz	DC-60kHz		DC-50kHz
Power consumption@24V	200mA					300mA			600mA

## HARDWARE DESCRIPTION

The IsoBlock I-ZF input connector is located at the top of the module in the figure below. A connector that serves to power the sensing unit, output signal and ground the sensor lay along the bottom.

The IsoBlock I-ZF is designed to mount on standard NS-35 or NS-32 DIN rails with minimal preparation, providing users ease of use and flexibility.

The current sensing component of the unit has an aperture located at the center of the unit. The connector in front of the unit is used to receive power and output the signal to conditioning unit.

Electrical	
Accuracy	$\pm(0.1\% \text{ of reading} + 0.005\% \text{ range})$ or $\pm(0.02\% \text{ of reading} + 0.005\% \text{ range})$
Gain	
Max total phase shift at 60Hz	$< 0.01^\circ$
Max Input delay	$< 1 \mu\text{s}$
Isolation voltage	5kV for 1min
Isolation voltage for transient	10kV for 50 $\mu\text{s}$
Insulation Resistance	$> 500\text{M}\Omega$ (@500V)
Thermal drift gain	$< \pm 0.01\% / ^\circ\text{C}$
Mechanical	
Mounting Type	DIN Rail and Panel
Weight	800g

Integrated sensor noise	
Input-Output non-linearity	$< 0.02\%$ or $< 0.005\%$
Output voltage	$\pm 10V$
Gain temperature drift	$\pm 50 \text{ ppm}/^\circ\text{C}$
Differential input dynamic range	
Power Supply Voltage	24V
Output type	Differential signal
Output Offset Voltage	$< \pm 500\mu\text{V}$
Output impedance	30 $\Omega$
Environmental	
Operating temperature	$- 25$ to $70^\circ\text{C}$
Storage temperature	$- 40$ to $85^\circ\text{C}$

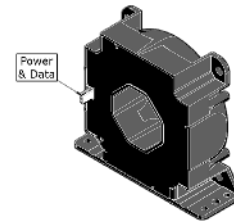

IsoBlock I-ZF Sensing Unit

# MERCHICAL DIMENSIONS

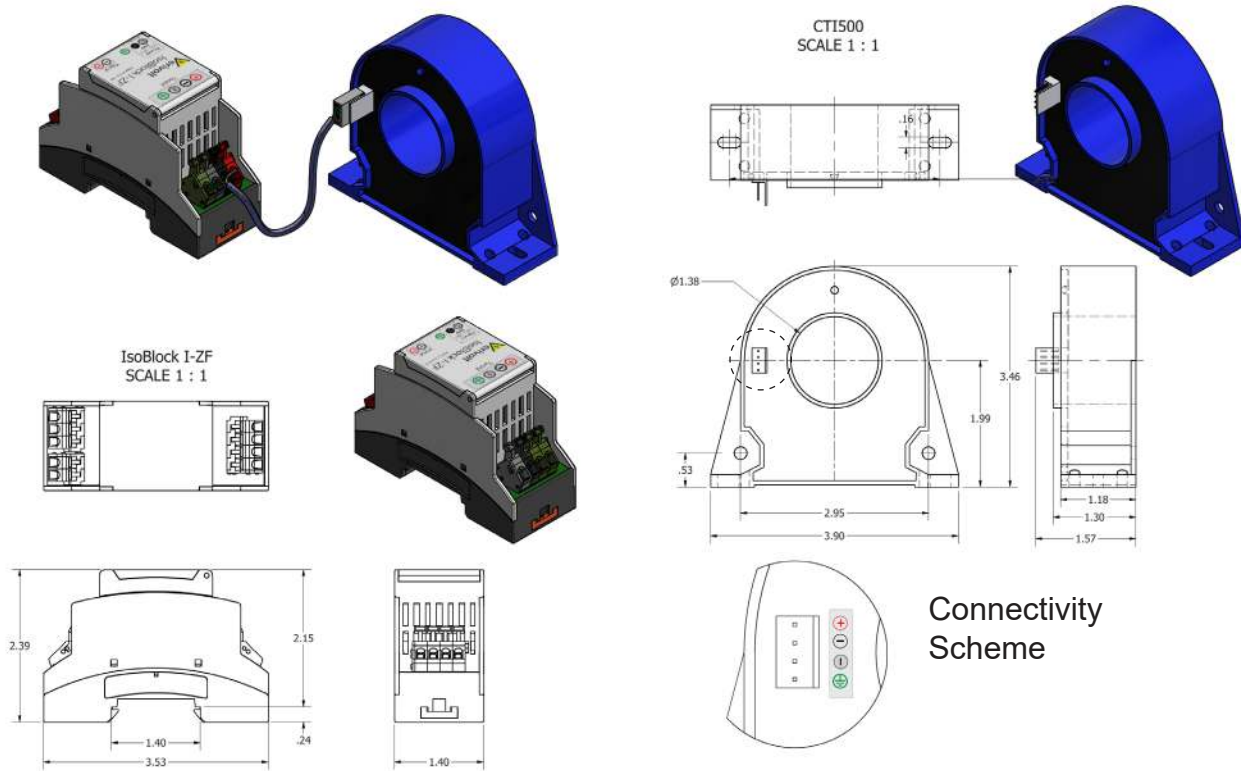

# HARDWARE CONFIGURATION

A. Connect external power source to power the unit. For proper functioning the power supply should provide a voltage as specified with at least 0.5A of continuous current and 1A surge during module start-up.

B. Pass conductor through aperture and observe orientation for proper signal polarity.

C. Securely connect one end of a 4 wire cable with corresponding connectors to IsoBlock I-ZF main unit, and the other end to the inputs of the sensing unit

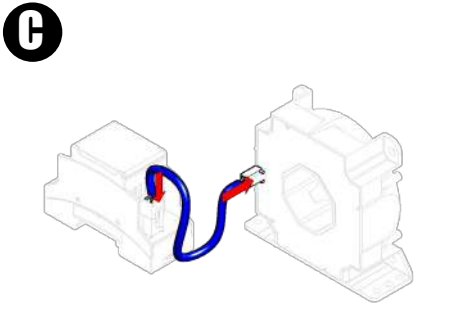
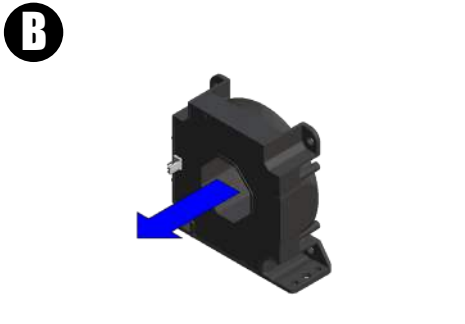
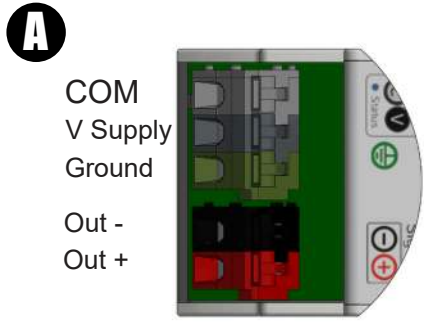

**Warning**

THIS SENSOR IS NOT A SAFETY DEVICE AND IS NOT INTENDED TO BE USED AS A SAFETY DEVICE. This sensor is designed only to detect and read certain data in an electronic manner and perform no use apart from that, specifically no safety-related use. This sensor product does not include self-checking redundant circuitry, and the failure of this sensor product could cause either an energized or de-energized output condition, which could result in death, serious bodily injury, or property damage.