

LTM4678

Dual 25A or Single 50A μ Module Regulator with Digital Power System Management, 1 \times LTM4678, 50A

DESCRIPTION

Demonstration circuit 2570A is a dual output, high efficiency, high density, μ Module[®] regulator with 4.5V to 16V input range. The output voltage is adjustable from 0.5V to 33V and it can supply 50A maximum load current. The demo board has a **LTM[®]4678** μ Module regulator, which is a dual 25A or single 50A step-down regulator with digital power system management. Please see LTM4678 data sheet for more detailed information.

DC2570A powers up to default settings and produces power based on configuration resistors without the need for any serial bus communication. This allows easy evaluation of the DC/DC converter. To fully explore the extensive power system management features of the

part, download the GUI software LTpowerPlay[®] onto your PC and use Analog Devices' I²C/SMBus/PMBus dongle DC1613A to connect to the board. LTpowerPlay allows the user to reconfigure the part on-the-fly and store the configuration in EEPROM, view telemetry of voltage, current, temperature and fault status.

GUI Download

The software can be downloaded from: [LTpowerPlay](#)

For more details and instructions of LTpowerPlay, please refer to LTpowerPlay GUI for LTM4678 Quick Start Guide.

[Design files for this circuit board are available.](#)

All registered trademarks and trademarks are the property of their respective owners.

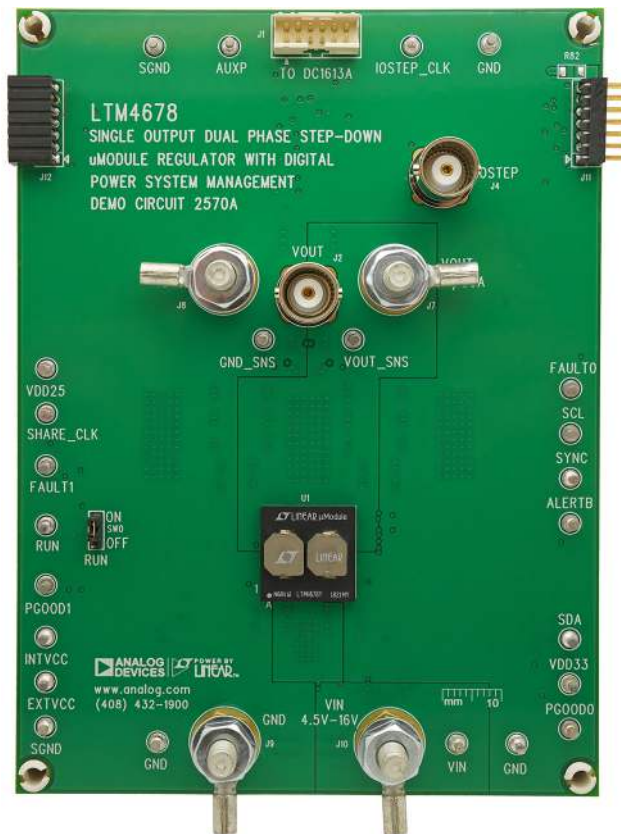

Figure 1. Single-Output 50A LTM4678/DC2570A Demo Circuit

DEMO MANUAL DC2570A

PERFORMANCE SUMMARY

Specifications are at $T_A = 25^\circ\text{C}$

PARAMETER	CONDITIONS	MIN	TYP	MAX	UNITS
Input Voltage Range		4.5		16	V
Output Voltage, V_{OUT}	$V_{IN} = 4.5\text{V to }16\text{V}$, $I_{OUT} = 0\text{A to }50\text{A}$	0.5	1.0	3.3	V
Maximum Output Current, I_{OUT}	$V_{IN} = 4.5\text{V to }16\text{V}$, $V_{OUT} = 0.5\text{V to }3.3\text{V}$		50		A
Typical Efficiency	$V_{IN} = 12\text{V}$, $V_{OUT} = 1.0\text{V}$, $I_{OUT} = 50\text{A}$		86 (See Figure 5)		%
Default Switching Frequency			500		kHz

QUICK START PROCEDURE

Table 1. LTM4678 Demo Boards for Up to 250A Point-of-Load Regulation

MAXIMUM OUTPUT CURRENT	NUMBER OF OUTPUTS	NUMBER OF LTM4676 μ Module REGULATORS ON THE BOARD	DEMO BOARD NUMBER
25A	2	1	DC2552A
50A	1	1	DC2570A
100A	1	2	DC2638A-A
150A	1	3	DC2638A-B
200A	1	4	DC2638A-C
250A	1	5	DC2638A-D

Demonstration circuit 2570A is easy to set up to evaluate the performance of the LTM4678. Refer to Figure 2 for the proper measurement equipment setup and follow the procedure below.

1. With power off, connect the input power supply to V_{IN} (4.5V to 16V) and GND (input return).
2. Connect the 1.0V output load between V_{OUT} and GND (initial load: no load).
3. Connect the DVMs to the input and output. Set default jumper position: SW1: ON.
4. Turn on the input power supply and check for the proper output voltages. V_{OUT} should be $1.0\text{V} \pm 0.5\%$.

5. Once the proper output voltage is established, adjust the load within the operating range and observe the output voltage regulation, ripple voltage and other parameters.
6. Connect the dongle and control the output voltages from the GUI. See LTpowerPlay GUI for the LTM4678 Quick Start Guide for details.

Note: When measuring the output or input voltage ripple, do not use the long ground lead on the oscilloscope probe. See Figure 3 for the proper scope probe technique. Short, stiff leads need to be soldered to the (+) and (-) terminals of an output capacitor. The probe's ground ring needs to touch the (-) lead and the probe tip needs to touch the (+) lead.

QUICK START PROCEDURE

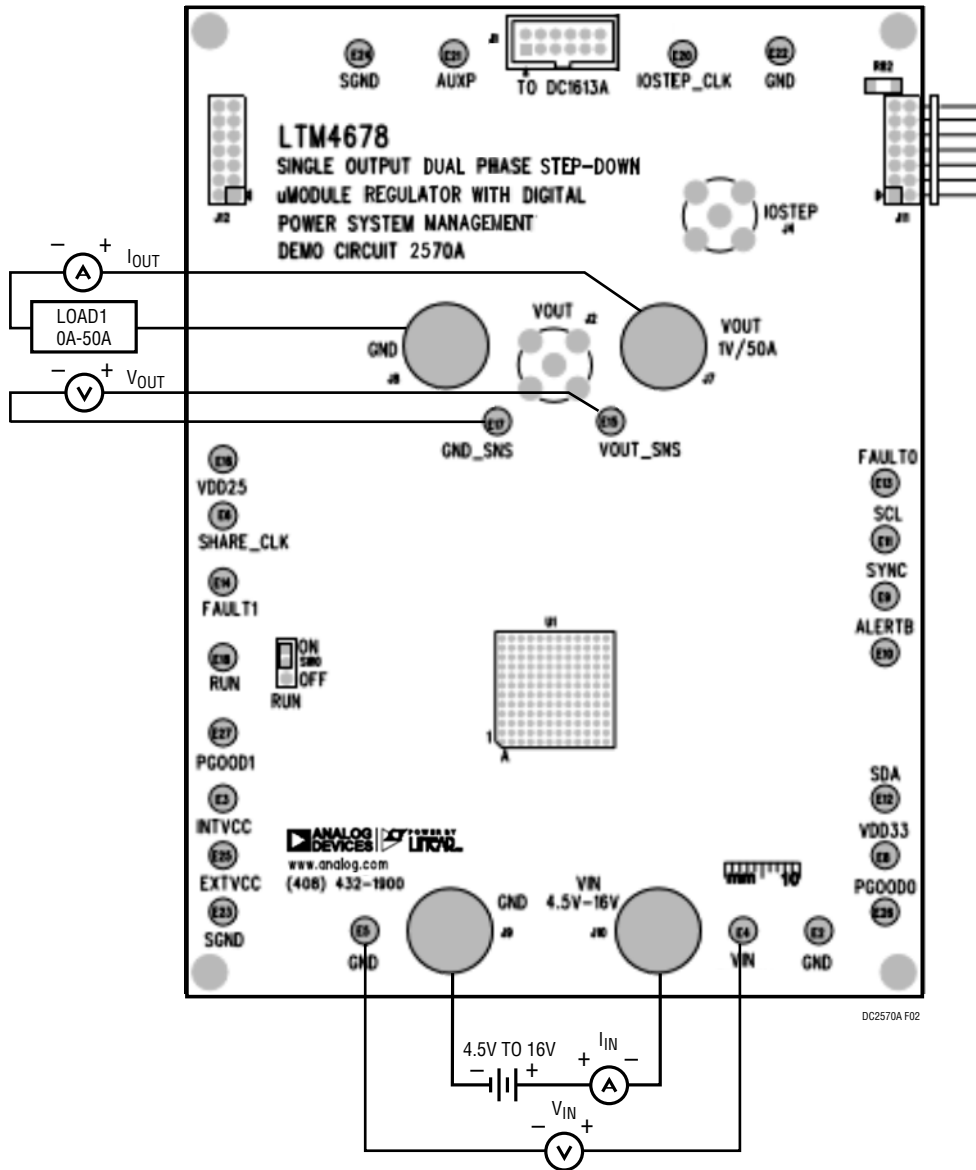

Figure 2. Proper Measurement Equipment Setup

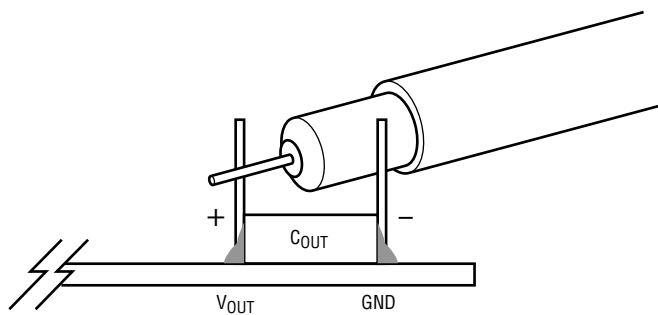

Figure 3. Measuring Output Voltage Ripple

QUICK START PROCEDURE

Connecting a PC to DC2570A

You can use a PC to reconfigure the power management features of the LTM4678 such as: nominal V_{OUT} , margin

set points, OV/UV limits, temperature fault limits, sequencing parameters, the fault log, fault responses, GPIOs and other functionalities. The DC1613A dongle may be plugged when V_{IN} is present.

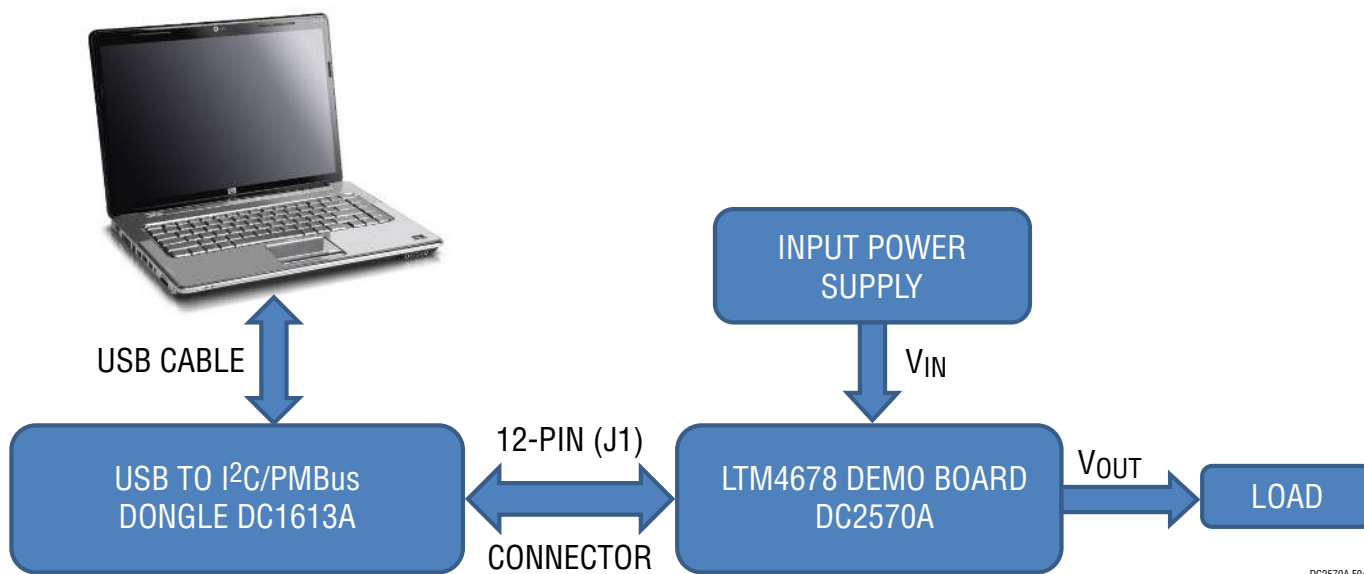

Figure 4. Demo Setup with PC

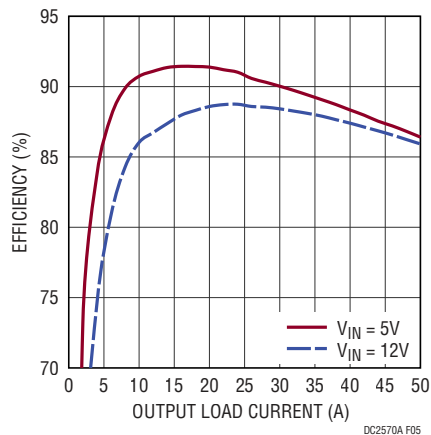

Figure 5. Efficiency vs Load Current at $V_{OUT} = 1.0V$

QUICK START PROCEDURE

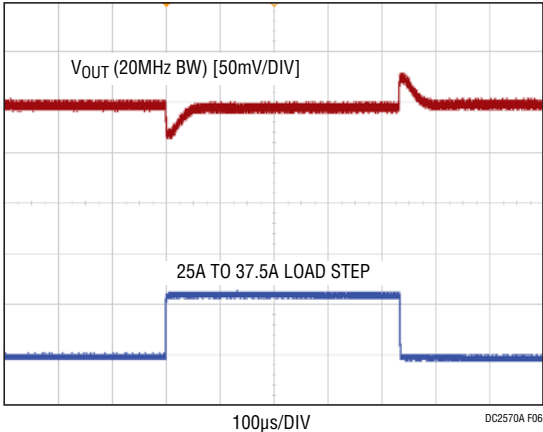

Figure 6. Output Voltage V_{OUT} vs Load Current ($V_{OUT} = 1.0V$)

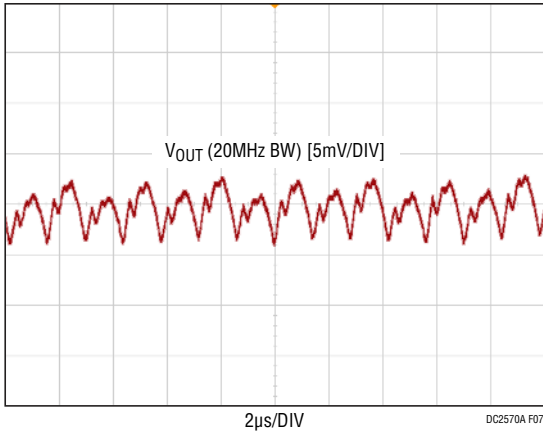

Figure 7. Output Voltage Ripple at $V_{IN} = 12V$, $V_{OUT} = 1.0V$, $I_{OUT} = 50A$

QUICK START PROCEDURE

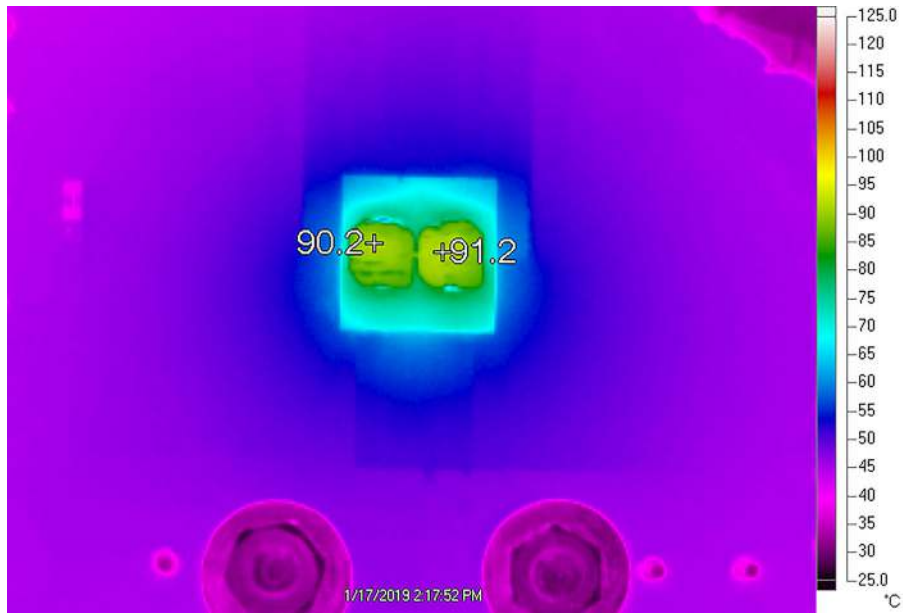

Figure 8. Thermal at $V_{IN} = 12V$, $V_{OUT} = 1.0V$, $I_{OUT} = 45A$, $T_A = 25^\circ C$, No Airflow

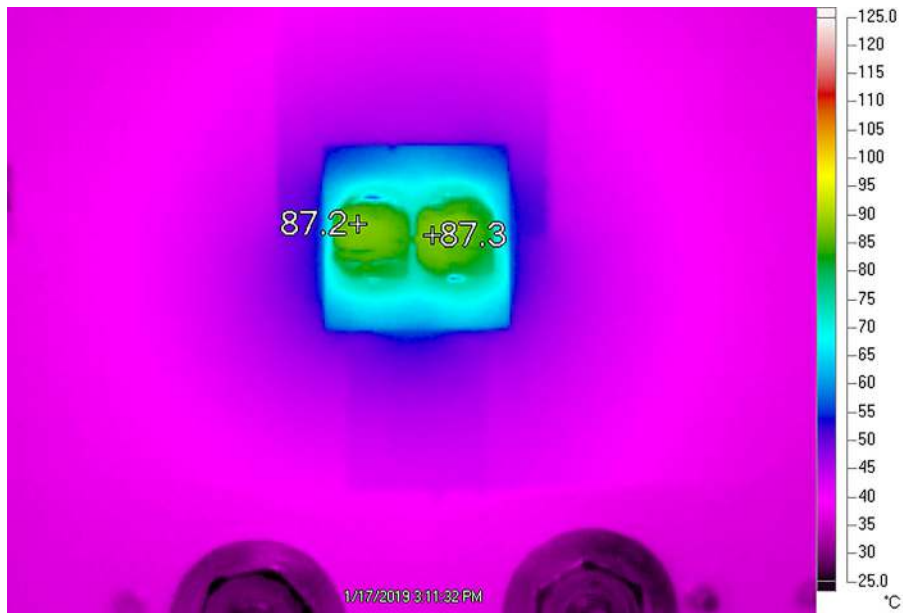

Figure 9. Thermal at $V_{IN} = 12V$, $V_{OUT} = 1.0V$, $I_{OUT} = 50A$, $T_A = 25^\circ C$, 200LFM Airflow

LTpowerPlay SOFTWARE GUI

LTpowerPlay is a powerful Windows based development environment that supports Analog Devices power system management ICs and μ Modules, including the LTM4675, LTM4676, LTM4677, LTM4678, LTC[®]3880, LTC3882 and LTC3883. The software supports a variety of different tasks. You can use LTpowerPlay to evaluate Analog Devices ICs by connecting to a demo board system. LTpowerPlay can also be used in an offline mode (with no hardware present) in order to build a multichip configuration file that can be saved and reloaded at a later time. LTpowerPlay provides unprecedented diagnostic and debug features. It becomes a valuable diagnostic tool during board bring-up to program or tweak the power management scheme in a system, or to diagnose power

issues when bringing up rails. LTpowerPlay utilizes the DC1613A USB-to-SMBus controller to communicate with one of many potential targets, including the LTM4675, LTM4676A, LTM4677, LTM4678, LTC3880, LTC3882, LTC3883's demo system, or a customer board. The software also provides an automatic update feature to keep the software current with the latest set of device drivers and documentation. The LTpowerPlay software can be downloaded from:

[LTpowerPlay](#)

To access technical support documents for Analog Devices Digital Power Products visit the LTpowerPlay Help menu. Online help also available through the LTpowerPlay.

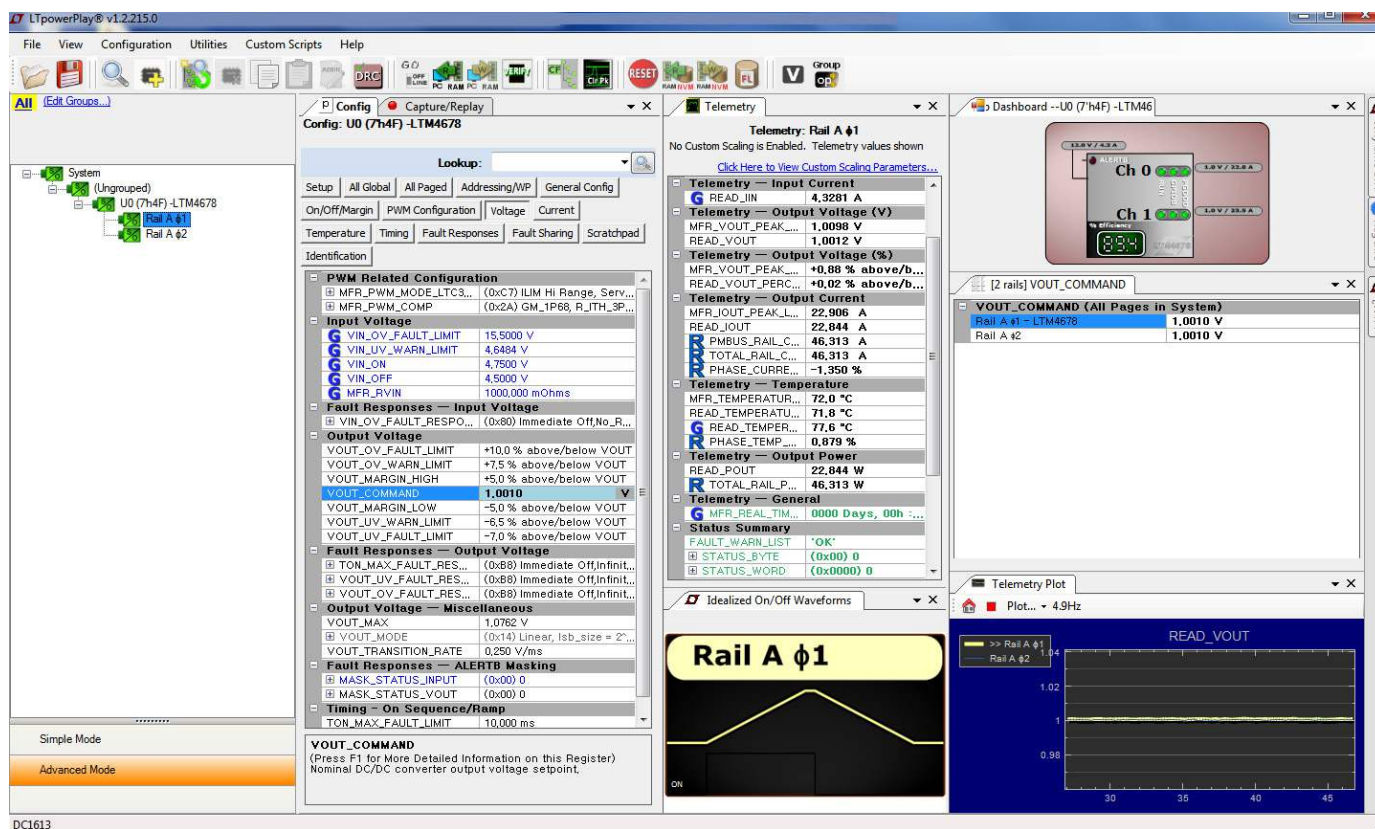

Figure 10. LTpowerPlay Main Interface

LTpowerPlay QUICK START PROCEDURE

The following procedure describes how to use LTpowerPlay to monitor and change the settings of LTM4678.

1. Download and install the LTpowerPlay GUI:

[LTpowerPlay](#)

2. Launch the LTpowerPlay GUI.

- a. The GUI should automatically identify the DC2570A. The system tree on the left hand side should look like this:

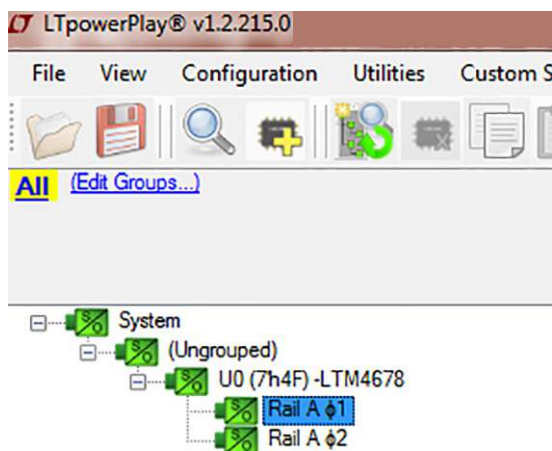

- b. A green message box shows for a few seconds in the lower left hand corner, confirming that LTM4678 is communicating:

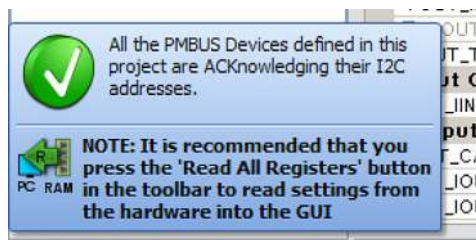

- c. In the Toolbar, click the “R” (RAM to PC) icon to read the RAM from the LTM4678. This reads the configuration from the RAM of LTM4678 and loads it into the GUI.



- d. If you want to change the output voltage to a different value, like 1.5V. In the Config tab, type in 1.5 in the VOUT_COMMAND box, like this:

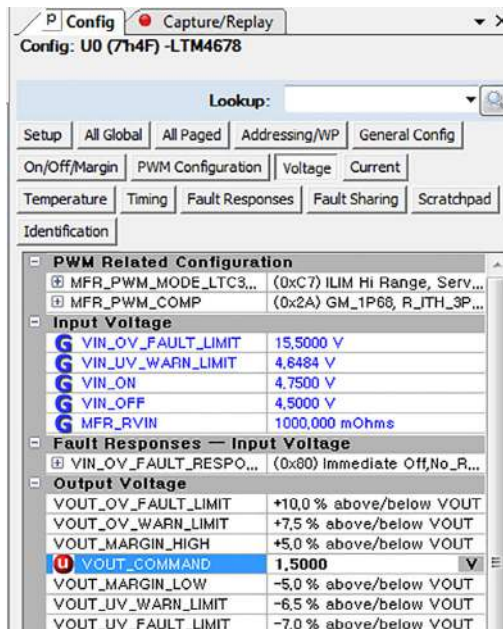

Then, click the “W” (PC to RAM) icon to write these register values to the LTM4678. After finishing this step, you will see the output voltage will change to 1.5V.



If the write is successful, you will see the following message:



- e. You can save the changes into the NVM. In the toolbar, click “RAM to NVM” button, as following:



- f. Save the demo board configuration to a (*.proj) file. Click the Save icon and save the file. Name it whatever you want.

PARTS LIST

ITEM	QTY	REFERENCE	PART DESCRIPTION	MANUFACTURER/PART NUMBER
Required Circuit Components				
1	1	CIN1	CAP, 150µF, ALUM POLY HYB, 35V, 20%	PANASONIC, EEH-ZA1V151P
2	6	COUT1, COUT2, COUT3, COUT6, COUT7, COUT8	CAP, 100µF, X5R, 6.3V, 20%, 1210	AVX, 12106D107MAT2A
3	4	CIN2, CIN3, CIN4, CIN5	CAP, 10µF, X5R, 35V, 10%, 1210	AVX, 1210DD106KAT2A NIC, NMC1210X5R106K35TRPLPF
4	4	COUT9, COUT10, COUT11, COUT12	CAP, 470µF, TANT. POSCAP, 4V, 20%, 7343, 10mΩ, TPF, NO SUBS. ALLOWED	PANASONIC, 4TPF470ML
5	2	C14, C28	CAP, 0.01µF, X7R, 25V, 5%, 0603	AVX, 06033C103JAT2A
6	1	C15	CAP, 270pF, X7R, 25V, 5%, 0603	AVX, 06033C271JAT2A
7	2	C21, C24	CAP, 1µF, X5R, 25V, 10%, 0603	AVX, 06033D105KAT2A NIC, NMC0603X5R105K25TRPF
8	1	C23	CAP, 1µF, X7R, 25V, 10%, 0805	AVX, 08053C105KAT2A
9	1	C26	CAP, 0.1µF, X5R, 16V, 10%, 0603	AVX, 0603YD104KAT2A NIC, NMC0603X5R104K16TRPF
10	1	C30	CAP, 4.7µF, X5R, 6.3V, 10%, 0603	AVX, 06036D475KAT2A MURATA, GRM188R60J475KE19D TDK, C1608X5R0J475K080AB
11	1	C33	CAP, 2.2µF, X5R, 6.3V, 10%, 0603	AVX, 06036D225KAT2A MURATA, GRM188R60J225KE19D TAIYO YUDEN, JMK107BJ225KA-T
22	1	Q1	XSTR., MOSFET, N-CH,40V, TO-252 (DPAK)	VISHAY, SUD50N04-8M8P-4GE3
23	1	Q19	XSTR., MOSFET, P-CH, 20V, 5.9A, TO-236 (SOT23-3)	VISHAY, SI2365EDS-T1-GE3
24	12	R9, R28, R29, R33, R63, R65, R66, R91, R92, R106, R107, R108	RES., 0Ω, 1/10W, 0603	NIC, NRC06ZOTRF VISHAY, CRCW06030000Z0EA
25	13	R10, R11, R12, R13, R14, R15, R16, R18, R19, R24, R52, R77, R95	RES., 10k, 1%, 1/10W, 0603, AEC-Q200	KOA SPEER, RK73H1JTDD1002F PANASONIC, ERJ3EKF1002V VISHAY, CRCW060310K0FKEA
26	3	R25, R32, R70	RES., 10Ω, 1%, 1/10W, 0603	NIC, NRC06F10R0TRF PANASONIC, ERJ3EKF10R0V ROHM, MCR03EZPF10R0 VISHAY, CRCW060310R0FKEA YAGEO, RC0603FR-0710RL
27	1	R27	RES., 22.6k, 1%, 1/10W, 0603	PANASONIC, ERJ3EKF2262V ROHM, MCR03EZPF2262 VISHAY, CRCW060322K6FKEA
28	2	R30, R31	RES., 2.43k, 1%, 1/10W, 0603, AEC-Q200	VISHAY, CRCW06032K43FKEA
30	1	R53	RES., 0.01Ω, 1%, 1/2W, 2010, SENSE, AEC-Q200	VISHAY, WSL2010R0100FEA
31	2	R72, R73	RES., 4.99k, 1%, 1/10W, 0603	NIC, NRC06F4991TRF VISHAY, CRCW06034K99FKEA
32	1	R78	RES., 15.8k, 1%, 1/10W, 0603, AEC-Q200	PANASONIC, ERJ3EKF1582V VISHAY, CRCW060315K8FKEA
33	1	R90	RES., 0.002Ω, 1%, 1/2W, 2010, SENSE, AEC-Q200	VISHAY, WSL20102L000FEA
43	1		TOOL, STENCIL, 700-DC2570A	ANALOG DEVICES, 830-DC2570A
44	1		CAP, OPTION, 7343	
45	1		LABEL SPEC, DEMO BOARD SERIAL NUMBER	BRADY, THT-96-717-10
46	0		PCA ASSY DWG, DC2570A	

DEMO MANUAL DC2570A

PARTS LIST

ITEM	QTY	REFERENCE	PART DESCRIPTION	MANUFACTURER/PART NUMBER
Additional Demo Board Circuit Components				
4	0	COUT4, COUT5	CAP., 70 μ F, TANT. POSCAP, 4V, 20%, 7343, 10m Ω , TPE, NO SUBS. ALLOWED	PANASONIC, 4TPF470ML
29	0	R50	RES., 30 Ω , 1%, 1W, 2512, AEC-Q200	VISHAY, CRCW251230R0FKEG
40	0		RES., OPTION, 0603	
41	0		DIODE, OPTION, SOD-323	
42	0		CAP., OPTION, 0603	
38	0		PCA SCHEMATIC, DC2570A	
Hardware for Demo Board Only				
12	24	E2, E3, E4, E5, E6, E8, E9, E10, E11, E12, E13, E14, E15, E16, E17, E18, E20, E21, E22, E23, E24, E25, E26, E27	TEST POINT, TURRET, 0.064", MTG. HOLE	MILL-MAX, 2308-2-00-80-00-00-07-0
13	1	J1	CONN., SHROUDED HDR, MALE, 2x6, 2mm, VERT, STR, THT	FCI, 98414-G06-12ULF
14	2	J2, J4	CONN., RF, BNC, RCPT JACK, 5-PIN, STR, THT, 50 Ω	AMPHENOL RF, 112404
15	8	J7, J8, J9, J10	NUT, HEX, STEEL, ZINC PLATE, 10-32	KEYSTONE, 4705
16	4	J7, J8, J9, J10	STUD, FASTENER, #10-32	PENNENGINEERING, KFH-032-10ET
17	4	J7, J8, J9, J10	WASHER, FLAT, STEEL, ZINC PLATE, OD: 0.436 [11.1]	KEYSTONE, 4703
18	4	J7, J8, J9, J10	RING, LUG, CRIMP, #10, NON-INSULATED, SOLDERLESS TERMINALS	KEYSTONE, 8205
19	1	J11	CONN., HDR, FEMALE, 2x7, 2mm, R/A THT	SULLINS CONNECTOR SOLUTIONS, NPPN072FJFN-RC
20	1	J12	CONN., HDR, MALE, 2x7, 2mm, R/A THT	MOLEX, 87760-1416
21	4	MH1, MH2, MH3, MH4	STANDOFF, NYLON, SNAP-ON, 0.50"	KEYSTONE, 8833
34	1	SW0	CONN., HDR., MALE, 1x3, 2mm, VERT, STR, THT, 10 μ " Au	SAMTEC, TMM-103-02-L-S
35	1	SW0	CONN., SHUNT, FEMALE, 2-POS, 2mm	SAMTEC, 2SN-BK-G
36	1	U1	IC, DUAL 25A POP PSM MODULE, BGA-144 (16mm x 16mm x 6.16mm)	ANALOG DEVICES, LTM4678EY#PBF
37	1	U2	IC, MEMORY, EEPROM, 2-Kb (256x8), TSSOP-8, 400kHz	MICROCHIP, 24LC025-I/ST MICROCHIP, 24LC025T-I/ST
39	1		PCB, DC2570A	MAO BANG, 600-DC2570A

SCHEMATIC DIAGRAM

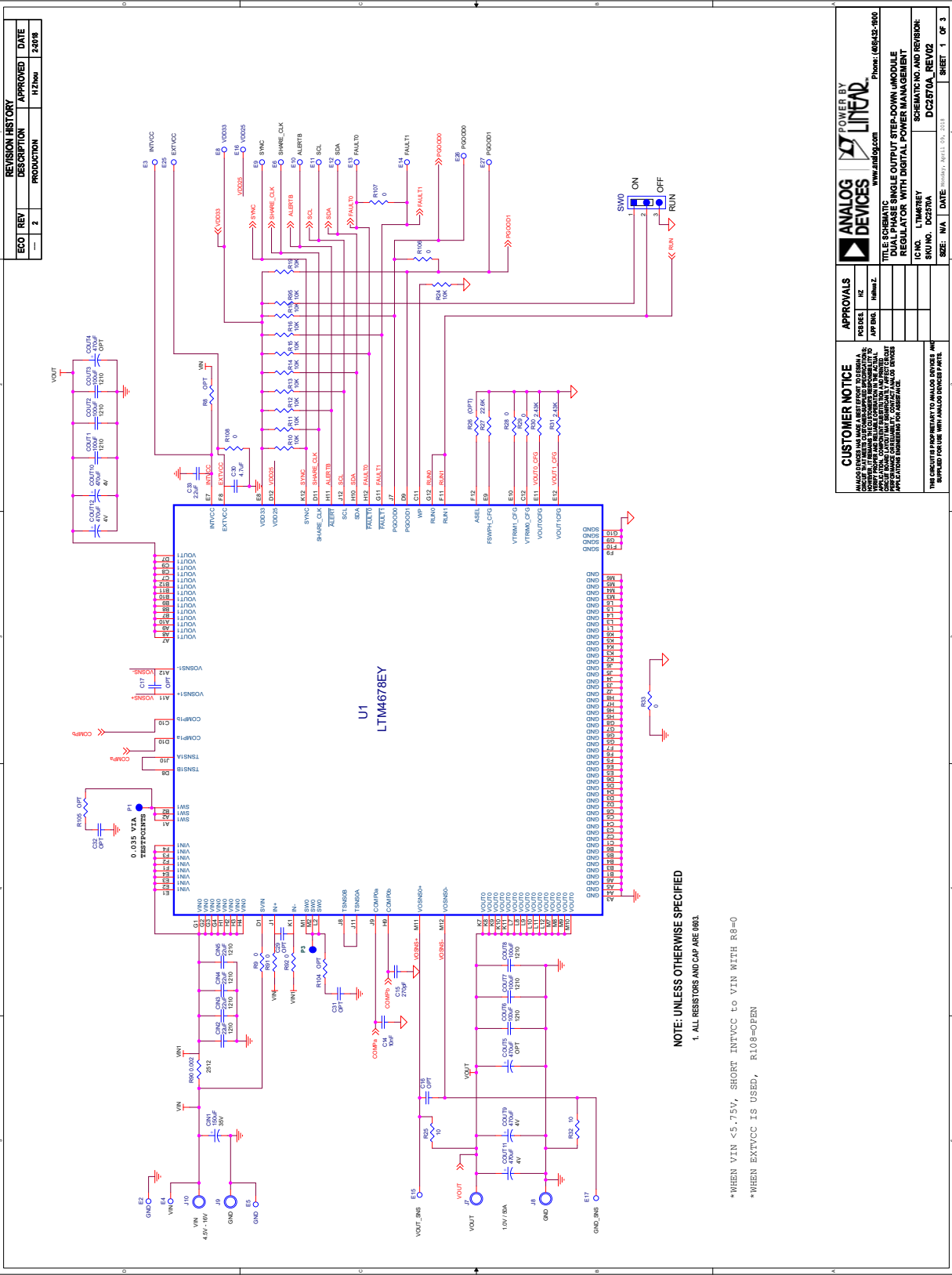

ECO	REV	DESCRIPTION	APPROVED	DATE
—	2	PRODUCTION	HZhou	2-2018

REVISION HISTORY

POWER BY
ANALOG DEVICES
www.analog.com

PHONE: (408)435-9000

TITLE SCHEMATIC
SINGLE OUTPUT STEP-DOWN MODULE
REGULATOR WITH DIGITAL POWER MANAGEMENT

IC NO. LTM4678EY
SKU NO. DC2570A

SCHEMATIC NO. AND REVISION:
DC2570A REV/02

SIZE: 8VA DATE: 02/2018 19:33:03 SHEET 1 OF 3

CUSTOMER NOTICE
THIS SCHEMATIC DIAGRAM IS PROVIDED AS A GUIDE ONLY. IT IS NOT INTENDED TO BE USED AS A SUBSTITUTE FOR THE ORIGINAL PRODUCT. THE USER SHALL BE RESPONSIBLE FOR VERIFYING THE CORRECTNESS OF THE SCHEMATIC AND THE PARTS LIST. THE USER SHALL BE RESPONSIBLE FOR OBTAINING THE NECESSARY PERMITS AND APPROVALS FOR THE USE OF THIS SCHEMATIC IN ANY APPLICATION. THE USER SHALL BE RESPONSIBLE FOR OBTAINING THE NECESSARY PERMITS AND APPROVALS FOR THE USE OF THIS SCHEMATIC IN ANY APPLICATION.

THIS SCHEMATIC DIAGRAM IS THE PROPERTY OF ANALOG DEVICES, INC. AND IS NOT TO BE REPRODUCED OR TRANSMITTED IN ANY FORM OR BY ANY MEANS, ELECTRONIC OR MECHANICAL, INCLUDING PHOTOCOPYING, RECORDING, OR BY ANY INFORMATION STORAGE AND RETRIEVAL SYSTEM, WITHOUT THE WRITTEN PERMISSION OF ANALOG DEVICES, INC.

NOTE: UNLESS OTHERWISE SPECIFIED
1. ALL RESISTORS AND CAP ARE 0603.

*WHEN VIN < 5.75V, SHORT INTVCC TO VIN WITH R8=0
*WHEN EXTVCC IS USED, R108=OPEN

SCHEMATIC DIAGRAM

ALL PARTS ON THIS PAGE ARE FOR DEMO ONLY, NOT NEEDED IN CUSTOMER DESIGN

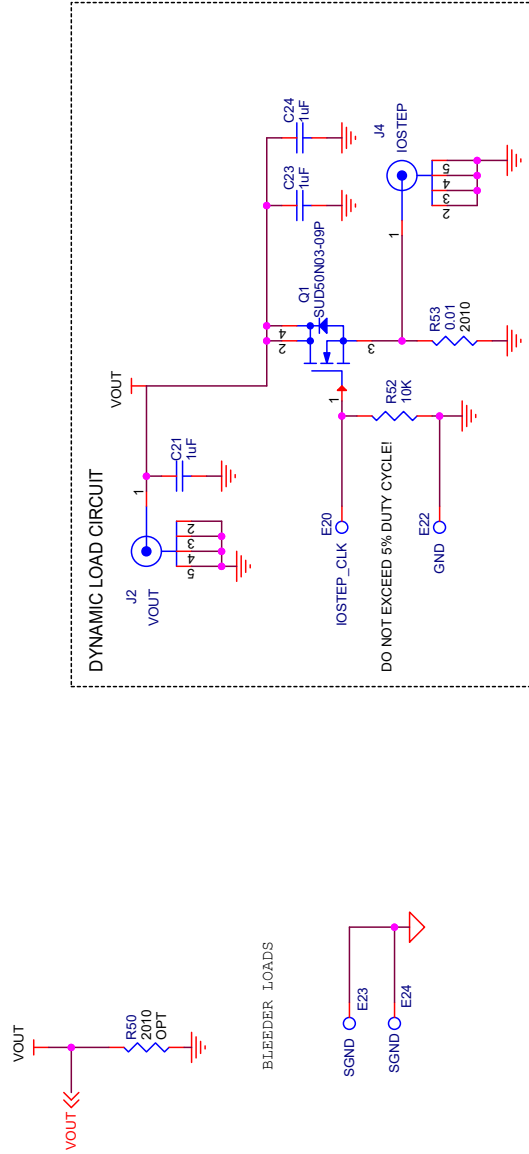

POWER BY ANALOG DEVICES		www.analog.com Phone: (408)432-1900	
TITLE: SCHEMATIC DUAL PHASE SINGLE OUTPUT STEP-DOWN uMODULE REGULATOR WITH DIGITAL POWER MANAGEMENT			
IC NO. LTM4678EY		SCHEMATIC NO. AND REVISION: DC2570A_REV02	
SKU NO. DC2570A		SIZE: N/A DATE:	
SHEET 2 OF 3		DATE:	
CUSTOMER NOTICE ANALOG DEVICES HAS MADE A BEST EFFORT TO DESIGN A CIRCUIT THAT MEETS CUSTOMER-SUPPLIED SPECIFICATIONS; HOWEVER, IT REMAINS THE CUSTOMER'S RESPONSIBILITY TO VERIFY PROPER AND RELIABLE OPERATION IN THE ACTUAL APPLICATION. COMPONENT SUBSTITUTION AND PRINTED CIRCUIT BOARD LAYOUT MAY SIGNIFICANTLY AFFECT CIRCUIT PERFORMANCE. CONTACT AN ANALOG DEVICES APPLICATIONS ENGINEERING FOR ASSISTANCE.		APPROVALS	
PCB DES.	HZ	Hailhua Z.	
APP ENG.	HZ	Hailhua Z.	
THIS CIRCUIT IS PROPRIETARY TO ANALOG DEVICES AND SUPPLIED FOR USE WITH ANALOG DEVICES PARTS.			

SCHEMATIC DIAGRAM

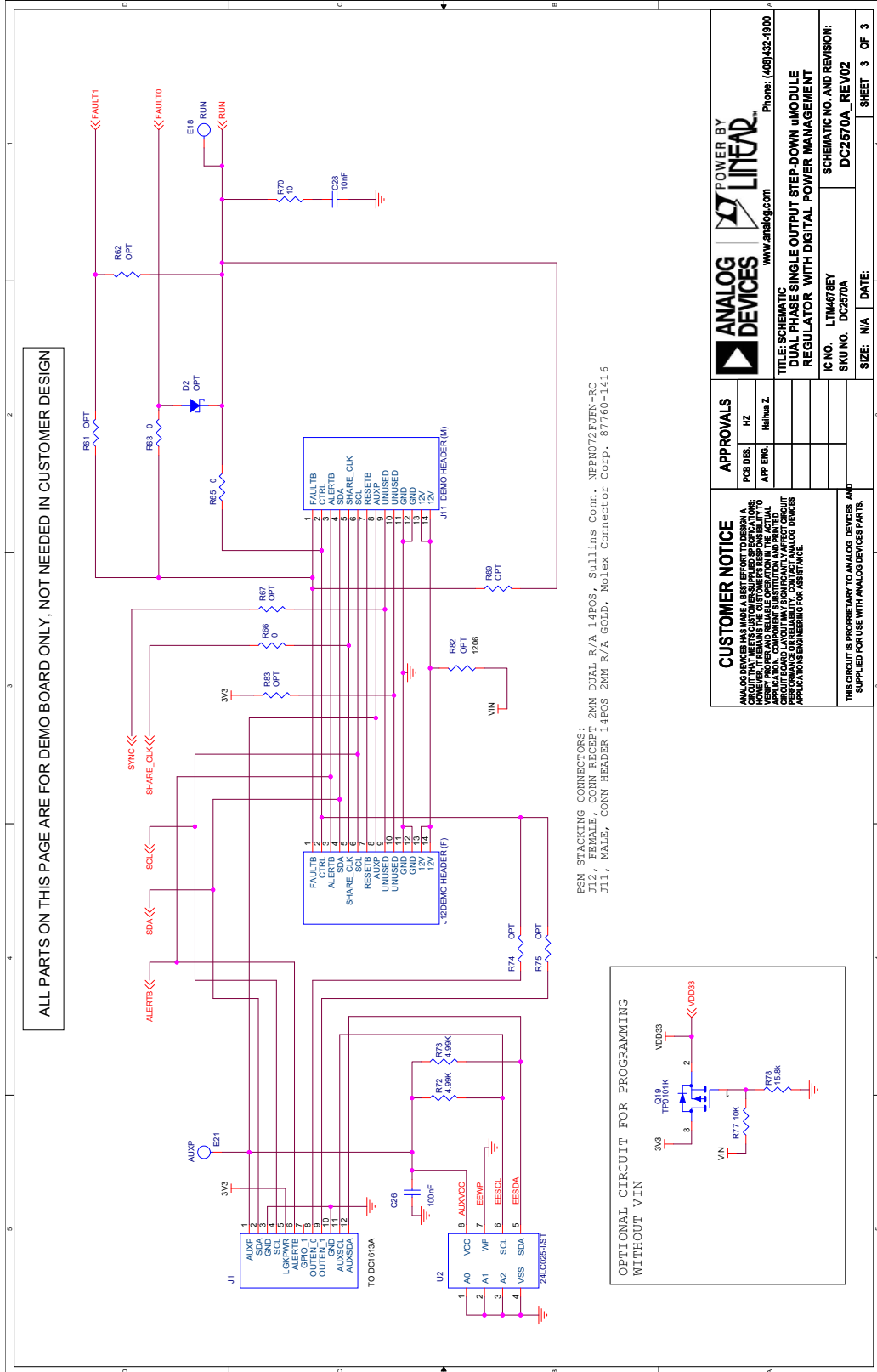

ANALOG DEVICES
www.analog.com

POWER BY
LINEAR
www.linear.com

Phone: (408)432-1900

APPROVALS	
POB DES:	HZ
APP ENG:	Hilma Z
TITLE: SCHEMATIC	
DUAL PHASE SINGLE OUTPUT STEP-DOWN MODULE REGULATOR WITH DIGITAL POWER MANAGEMENT	
IC NO.:	LTM478EY
SKU NO.:	DC2570A
SCHEMATIC NO. AND REVISION: DC2570A_REV02	
SIZE:	N/A
DATE:	
SHEET:	3 OF 3

CUSTOMER NOTICE
 ANALOG DEVICES HAS MADE A BEST EFFORT TO DESIGN A CIRCUIT THAT MEETS CUSTOMER SUPPLIED SPECIFICATIONS. HOWEVER, ANALOG DEVICES DOES NOT WARRANT THE PROPER PERFORMANCE OR RELIABILITY. CONTACT ANALOG DEVICES APPLICATION ENGINEERING FOR ASSISTANCE.

THIS CIRCUIT IS PROPRIETARY TO ANALOG DEVICES AND SUPPLIED FOR USE WITH ANALOG DEVICES PARTS.



ESD Caution

ESD (electrostatic discharge) sensitive device. Charged devices and circuit boards can discharge without detection. Although this product features patented or proprietary protection circuitry, damage may occur on devices subjected to high energy ESD. Therefore, proper ESD precautions should be taken to avoid performance degradation or loss of functionality.

Legal Terms and Conditions

By using the evaluation board discussed herein (together with any tools, components documentation or support materials, the "Evaluation Board"), you are agreeing to be bound by the terms and conditions set forth below ("Agreement") unless you have purchased the Evaluation Board, in which case the Analog Devices Standard Terms and Conditions of Sale shall govern. Do not use the Evaluation Board until you have read and agreed to the Agreement. Your use of the Evaluation Board shall signify your acceptance of the Agreement. This Agreement is made by and between you ("Customer") and Analog Devices, Inc. ("ADI"), with its principal place of business at One Technology Way, Norwood, MA 02062, USA. Subject to the terms and conditions of the Agreement, ADI hereby grants to Customer a free, limited, personal, temporary, non-exclusive, non-sublicensable, non-transferable license to use the Evaluation Board FOR EVALUATION PURPOSES ONLY. Customer understands and agrees that the Evaluation Board is provided for the sole and exclusive purpose referenced above, and agrees not to use the Evaluation Board for any other purpose. Furthermore, the license granted is expressly made subject to the following additional limitations: Customer shall not (i) rent, lease, display, sell, transfer, assign, sublicense, or distribute the Evaluation Board; and (ii) permit any Third Party to access the Evaluation Board. As used herein, the term "Third Party" includes any entity other than ADI, Customer, their employees, affiliates and in-house consultants. The Evaluation Board is NOT sold to Customer; all rights not expressly granted herein, including ownership of the Evaluation Board, are reserved by ADI. CONFIDENTIALITY. This Agreement and the Evaluation Board shall all be considered the confidential and proprietary information of ADI. Customer may not disclose or transfer any portion of the Evaluation Board to any other party for any reason. Upon discontinuation of use of the Evaluation Board or termination of this Agreement, Customer agrees to promptly return the Evaluation Board to ADI. ADDITIONAL RESTRICTIONS. Customer may not disassemble, decompile or reverse engineer chips on the Evaluation Board. Customer shall inform ADI of any occurred damages or any modifications or alterations it makes to the Evaluation Board, including but not limited to soldering or any other activity that affects the material content of the Evaluation Board. Modifications to the Evaluation Board must comply with applicable law, including but not limited to the RoHS Directive. TERMINATION. ADI may terminate this Agreement at any time upon giving written notice to Customer. Customer agrees to return to ADI the Evaluation Board at that time. LIMITATION OF LIABILITY. THE EVALUATION BOARD PROVIDED HEREUNDER IS PROVIDED "AS IS" AND ADI MAKES NO WARRANTIES OR REPRESENTATIONS OF ANY KIND WITH RESPECT TO IT. ADI SPECIFICALLY DISCLAIMS ANY REPRESENTATIONS, ENDORSEMENTS, GUARANTEES, OR WARRANTIES, EXPRESS OR IMPLIED, RELATED TO THE EVALUATION BOARD INCLUDING, BUT NOT LIMITED TO, THE IMPLIED WARRANTY OF MERCHANTABILITY, TITLE, FITNESS FOR A PARTICULAR PURPOSE OR NON-INFRINGEMENT OF INTELLECTUAL PROPERTY RIGHTS. IN NO EVENT WILL ADI AND ITS LICENSORS BE LIABLE FOR ANY INCIDENTAL, SPECIAL, INDIRECT, OR CONSEQUENTIAL DAMAGES RESULTING FROM CUSTOMER'S POSSESSION OR USE OF THE EVALUATION BOARD, INCLUDING BUT NOT LIMITED TO LOST PROFITS, DELAY COSTS, LABOR COSTS OR LOSS OF GOODWILL. ADI'S TOTAL LIABILITY FROM ANY AND ALL CAUSES SHALL BE LIMITED TO THE AMOUNT OF ONE HUNDRED US DOLLARS (\$100.00). EXPORT. Customer agrees that it will not directly or indirectly export the Evaluation Board to another country, and that it will comply with all applicable United States federal laws and regulations relating to exports. GOVERNING LAW. This Agreement shall be governed by and construed in accordance with the substantive laws of the Commonwealth of Massachusetts (excluding conflict of law rules). Any legal action regarding this Agreement will be heard in the state or federal courts having jurisdiction in Suffolk County, Massachusetts, and Customer hereby submits to the personal jurisdiction and venue of such courts. The United Nations Convention on Contracts for the International Sale of Goods shall not apply to this Agreement and is expressly disclaimed.