

PC BOARD VERSIONS		
PRODUCTNR.	PCB THICKNESS	DIM"A"
70227-X01LF		
70227-X11LF		

OBSOLETE 
OBSOLETE 

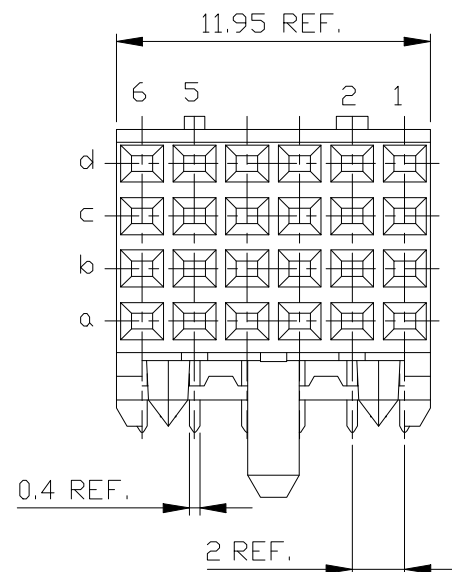

PRODUCT AFTER HOT RIVETTING

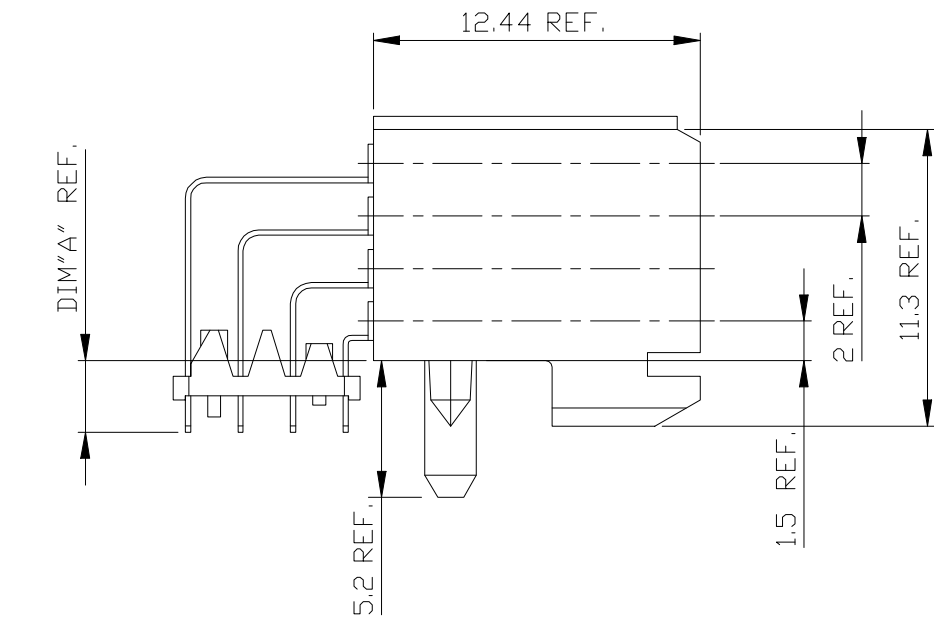
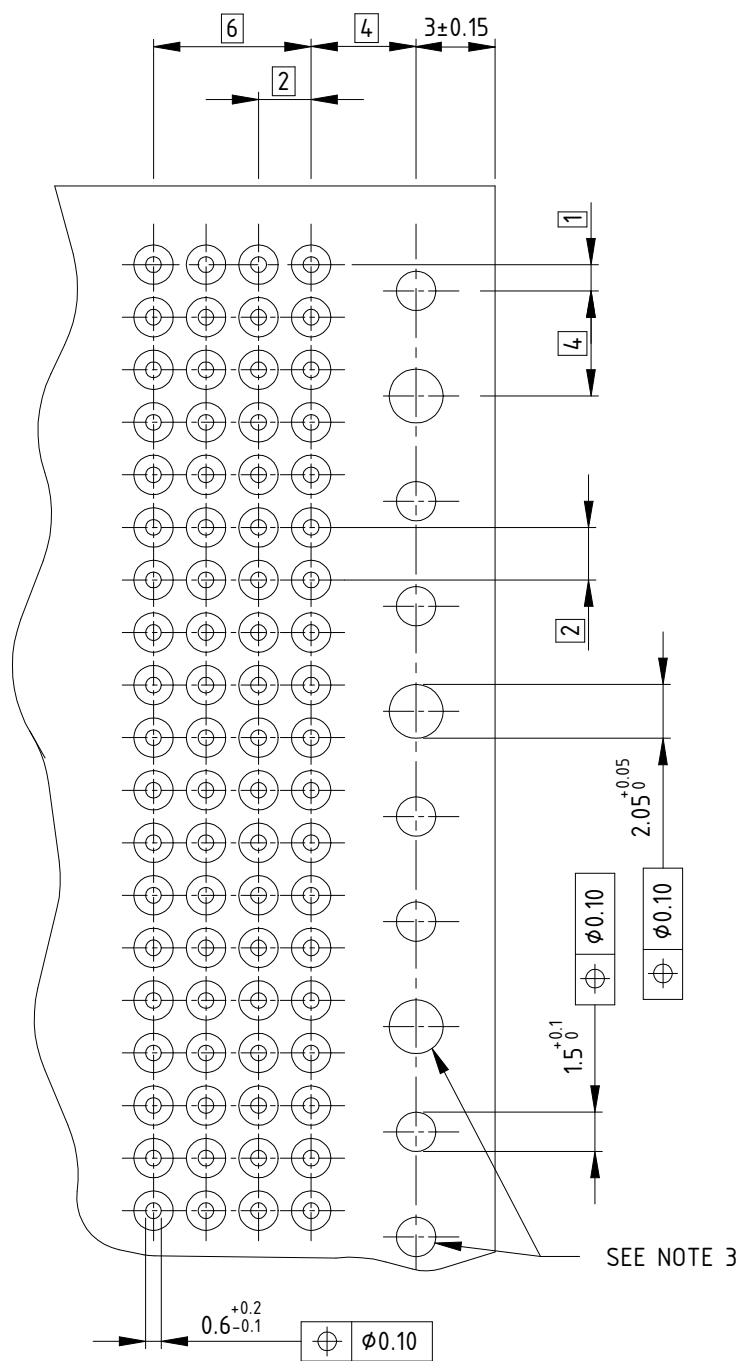
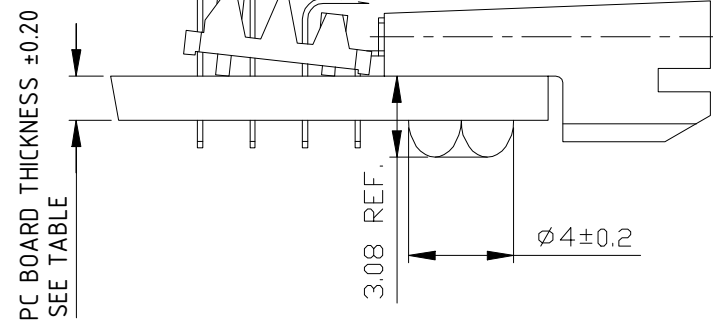
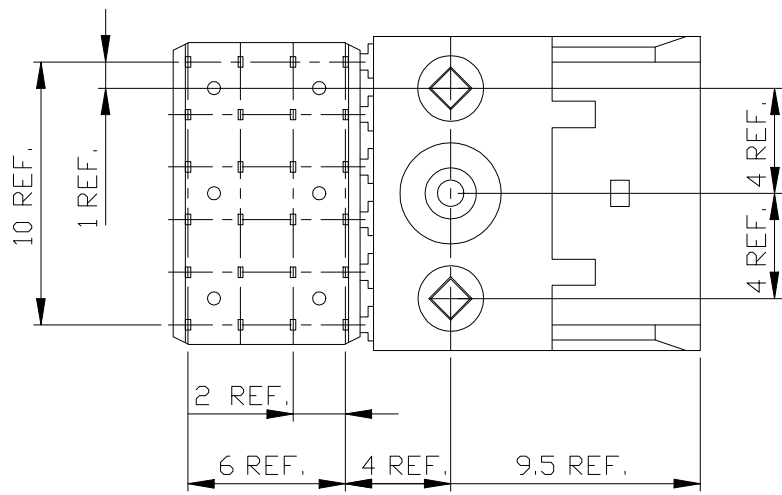

RECOMMENDED HOLE PATTERN,
COMPONENT SIDE.

NOTES:

- MATERIAL : BODY : LCP UL94-V0
: CONTACT : COPPER ALLOY.
- FOR PLATING SPECIFICATION REFER DRAWING NO : 10159408
- INDICATED HOLES ARE UNPLATED.
- THIS PRODUCT MEETS EUROPEAN UNION DIRECTIVES AND OTHER COUNTRY REGULATIONS AS DESCRIBED IN GS-47-0004.
- THE HOUSING WILL WITHSTAND EXPOSURE TO 260° PEAK TEMPERATURE FOR 10 SECONDS IN A WAVE SOLDER APPLICATION.
- A  SYMBOL WILL BE NEXT TO ANY DIMENSION, VIEW, OR NOTE WHICH HAS BEEN MODIFIED WITH THE CURRENT DRAWING REVISION.

REFER NOTE 2

PART NUMBER : 70227-XY1LF

mat'l. code		surface ISO 1302 <input checked="" type="checkbox"/> ISO 406 ISO 1101		tolerance ISO 1302 <input checked="" type="checkbox"/> ISO 406 ISO 1101		projection 		product family METRAL	
lfr		ecn no		dr		date		title	
K	DG04-0104	CLU	2004-12-21	engr		R.TRIPPE		RA FEMALE SIGNAL	
L	DG06-0477	CENH	2006-11-17	engr		NIRMAL SAM		STB 12mm VERSION	
M	DG07-0168	CENH	2007-05-10	chr		ALEX BABU		dwg no	
N	DG09-0068	CENH	2009-03-03	appd		SAN0J		sheet 1 of 3	
P	ELX-I-38655	MINI	2020-09-25	appd		SAN0J		size	
R	ELX-I-44040	NIRHAL	2022-03-05	appd		SAN0J		A2	
sheet index		revision sheet		R		R		type	
1		1		2		3		Product Customer Drawing	

PC BOARD VERSIONS		
PRODUCTNR:	PCB THICKNESS	DIM"A"
70227-X02LF	1.6	2.90
70227-X12LF	2.4	3.53
70227-T02LF	1.6	2.90

CUSTOMER SPECIAL

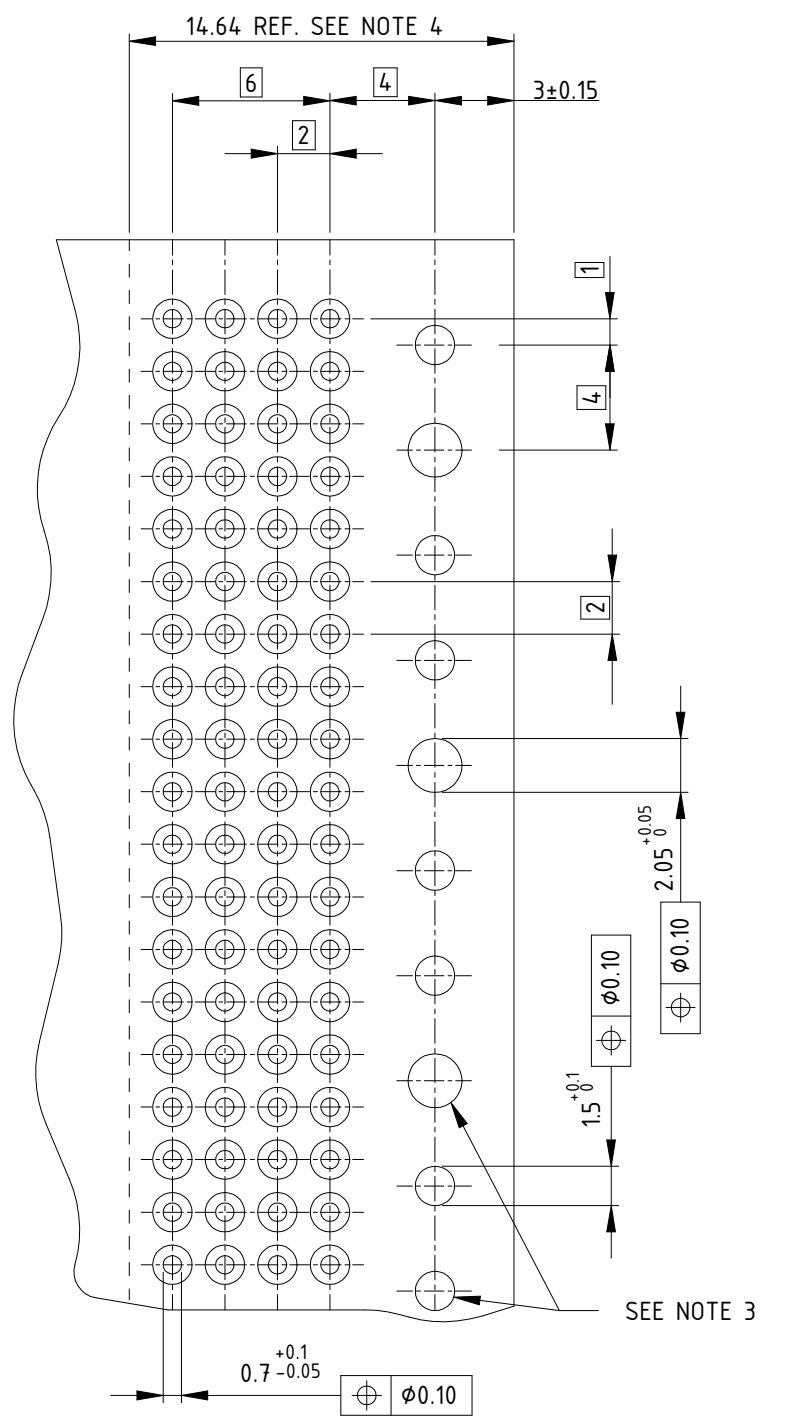
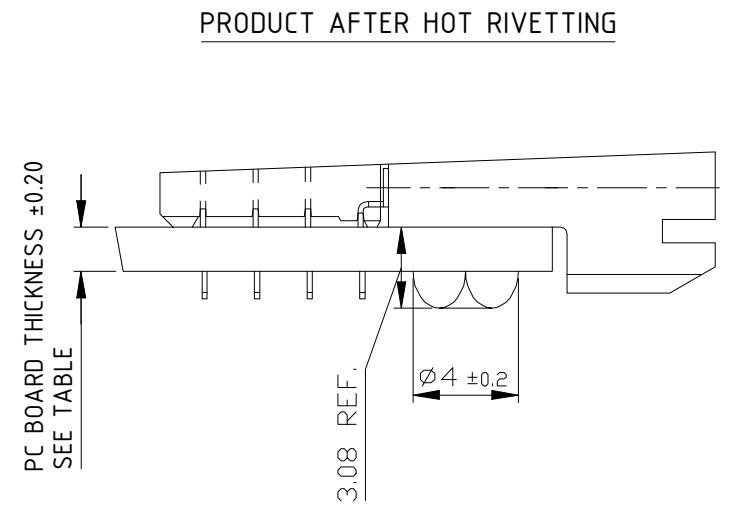
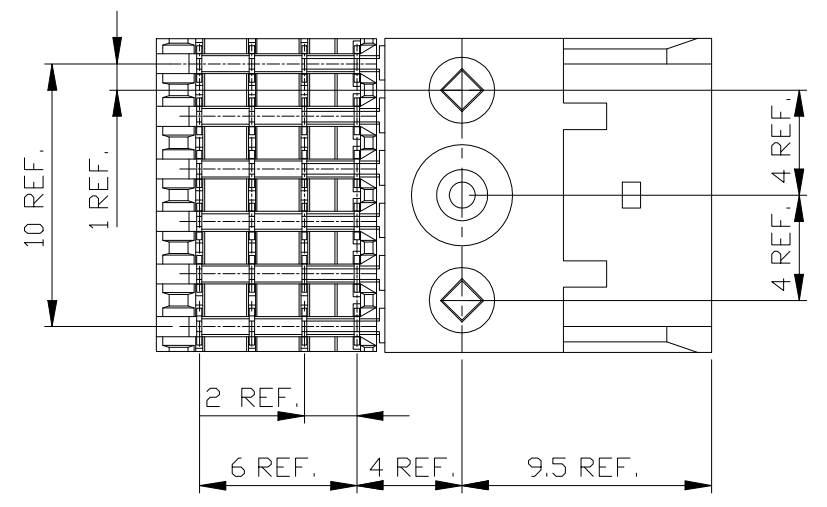
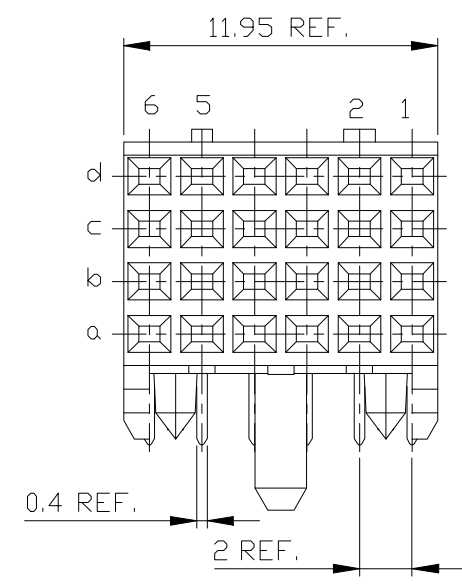
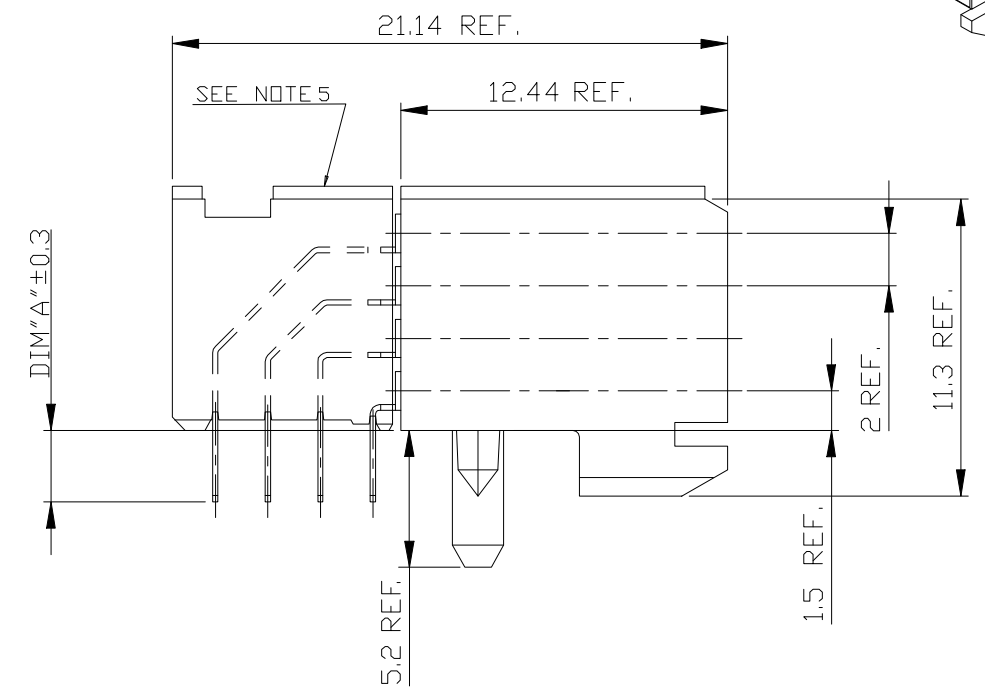
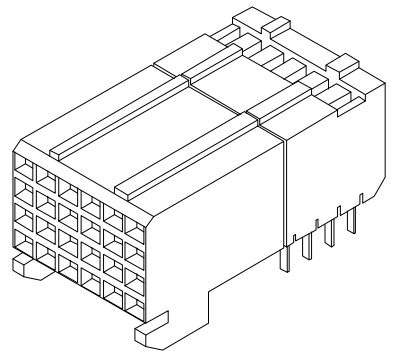

PRODUCT AFTER HOT RIVETTING

RECOMMENDED HOLE PATTERN, COMPONENT SIDE.

- NOTES:
- MATERIAL : BODY : LCP UL94-V0
: CONTACT : COPPER ALLOY.
 - FOR PLATING SPECIFICATION REFER DRAWING NO : 10159408
 - INDICATED HOLES ARE UNPLATED
 - SET BACK FOR PRESS BLOCK
 - TOP SURFACE OF PRESS BLOCK MAY EXTEND UP TO 0.4MM HIGHER THAN HOUSING. THIS MAY AFFECT THE TAIL LENGTH BEFORE APPLICATION TO A BOARD.
 - THIS PRODUCT MEETS EUROPEAN UNION DIRECTIVES AND OTHER COUNTRY REGULATIONS AS DESCRIBED IN GS-47- 0004
 - THE HOUSING WILL WITHSTAND EXPOSURE TO 260° PEAK TEMPERATURE FOR 10 SECONDS IN A WAVE SOLDER APPLICATION
 - A Δ SYMBOL WILL BE NEXT TO ANY DIMENSION, VIEW, OR NOTE WHICH HAS BEEN MODIFIED WITH THE CURRENT DRAWING REVISION.

PART NUMBER : 70227-XYLF

REFER NOTE 2

mat'l. code		surface		tolerance		projection		product family	
		ISO 1302		ISO 406 ISO 1101		mm		METRAL	
lfr		ecn no		dr		date		title	
K		DG04-0104		CLU		2004-12-21		RA FEMALE SIGNAL	
L		DG06-0477		CENH		2006-11-17		STB 12mm VERSION	
M		DG07-0168		CENH		2007-05-10		dwg no	
N		DG09-0068		CENH		2009-03-03		70227	
P		ELX-I-38655		MINI		2020-09-25		sheet 2 of 3	
R		ELX-I-44040		NIRHAL		2022-03-05		size	
								A2	
sheet		revision		R		R		type	
index		sheet		1		2		Product Customer Drawing	

PC BOARD VERSIONS		
PRODUCTNR:	PCB THICKNESS	DIM "A"
70227-X03LF	1.6	2.90
70227-X13LF	2.4	3.53

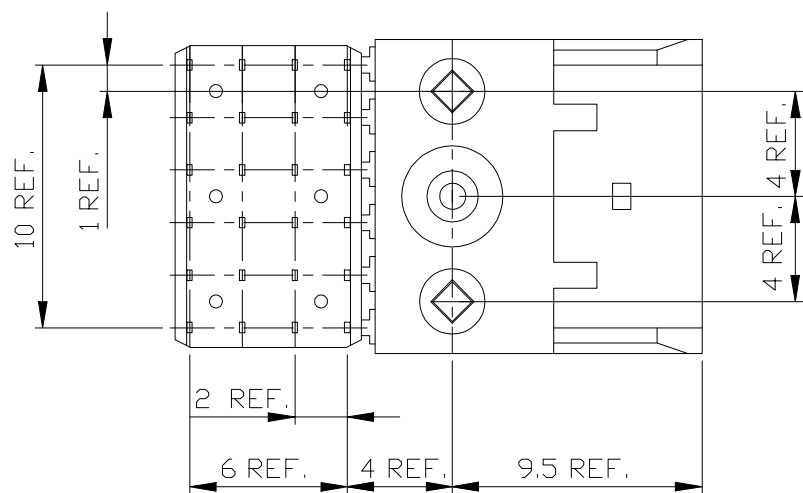
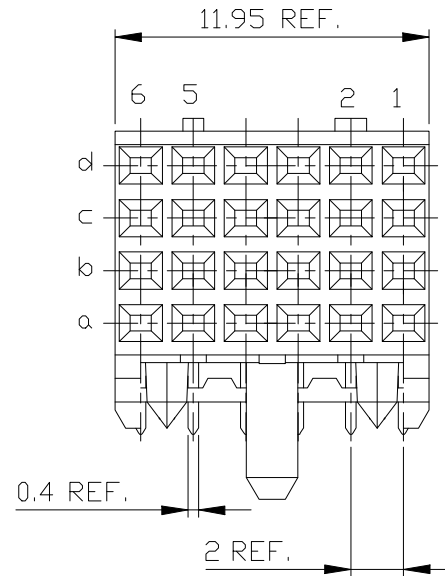
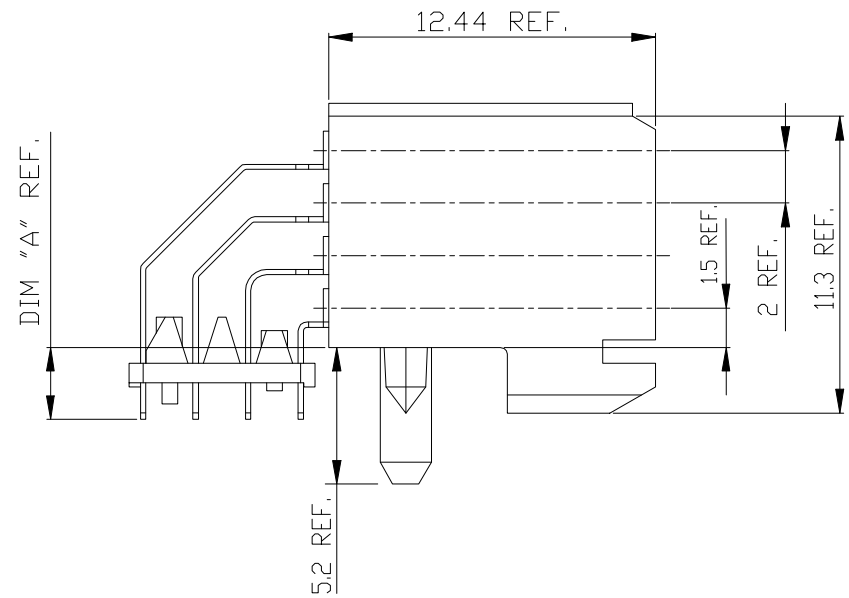

PRODUCT AFTER HOT RIVETTING

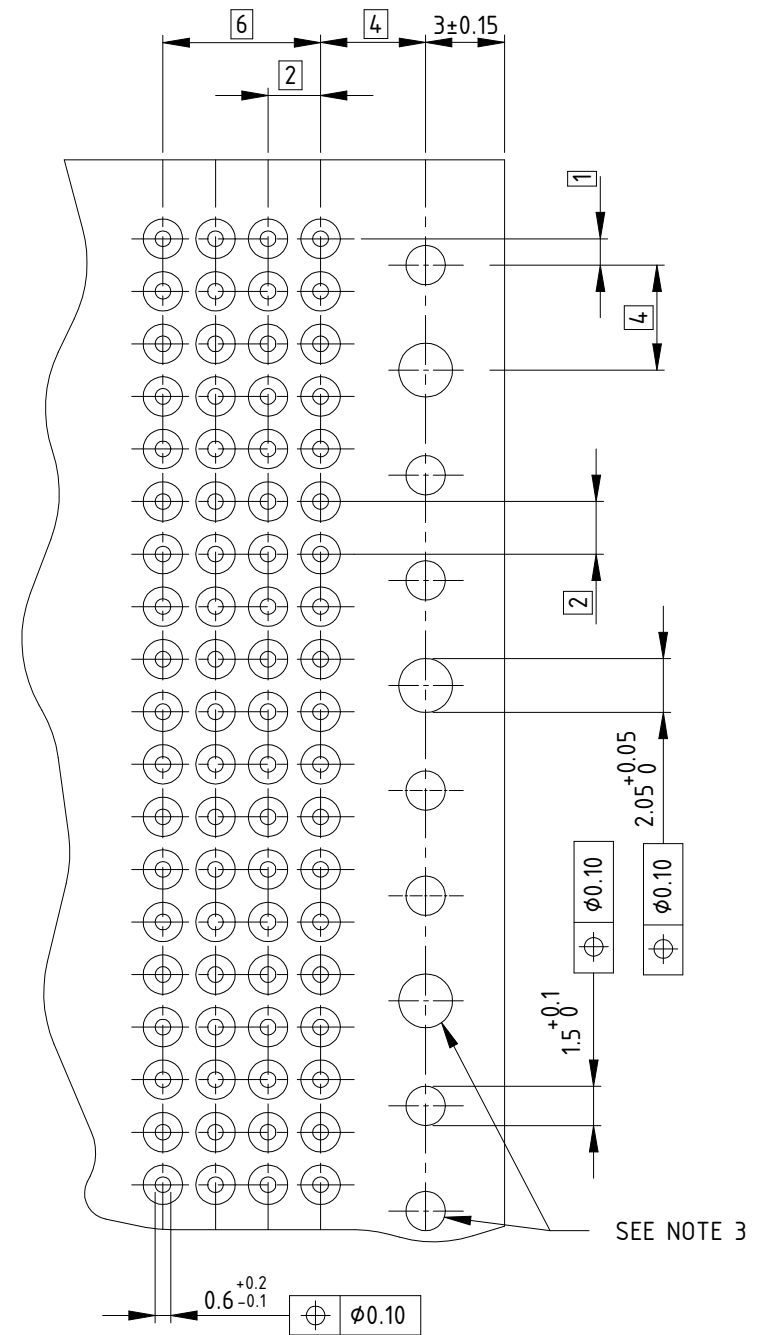
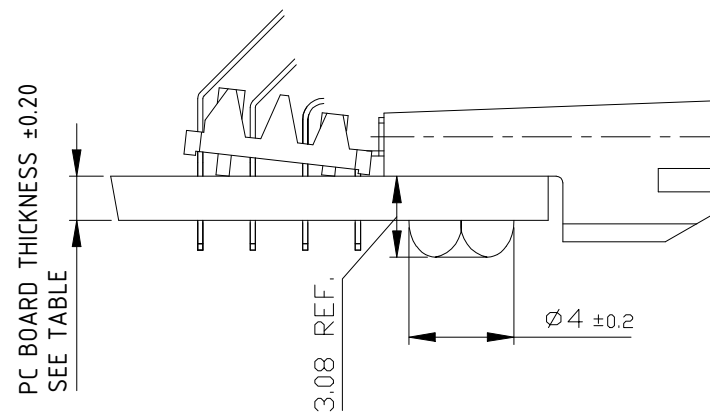

RECOMMENDED HOLE PATTERN, COMPONENT SIDE.

NOTES:

- MATERIAL : BODY : LCP UL94-V0
: CONTACT : COPPER ALLOY.
- FOR PLATING SPECIFICATION REFER DRAWING NO : 101594.08
- INDICATED HOLES ARE UNPLATED.
- THIS PRODUCT MEETS EUROPEAN UNION DIRECTIVES AND OTHER COUNTRY REGULATIONS AS DESCRIBED IN GS-47-0004.
- THE HOUSING WILL WITHSTAND EXPOSURE TO 260° PEAK TEMPERATURE FOR 10 SECONDS IN A WAVE SOLDER APPLICATION.
- A Δ SYMBOL WILL BE NEXT TO ANY DIMENSION, VIEW, OR NOTE WHICH HAS BEEN MODIFIED WITH THE CURRENT DRAWING REVISION.

PART NUMBER : 70227-XY1LF

REFER NOTE 2

mat'l. code		surface		tolerance		projection		product family	
		ISO 1302		ISO 406 ISO 1101		mm		METRAL	
lfr	ecn no	dr	date	tolerances unless otherwise specified		mm		title	
K	DG04-0104	CLU	2004-12-21	angles	linear	mm		RA FEMALE SIGNAL	
L	DG06-0477	CENH	2006-11-17			mm		STB 12mm VERSION	
M	DG07-0168	CENH	2007-05-10	0°±2°		mm		dwg no	
N	DG09-0068	CENH	2009-03-03	dr	R.TRIPPE	mm		sheet 3 of 3	
P	ELX-I-38655	MINI	2020-09-25	engr	NIRMAL SAM	mm		size	
R	ELX-I-44040	NIRMAL	2022-03-05	chr	ALEX BABU	mm		A2	
sheet index		revision	R	R	R	type		Product Customer Drawing	
1		sheet	1	2	3				