

REV.	DATE	ECR NO.	DESCRIPTION
A	07/26/99	-	REFORMAT - CHANGE TO NEXCOTE FINISH
B	05/24/00	-	MODIFY PLATING / ADD INSULATOR
C	07/08/04	-	UPDATE CABLE STRIPPING DIMS.
D	07/22/11	2205	CHANGE THE TOTAL LENGTH TO 20 REF

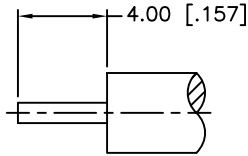

RECOMMENDED
CABLE STRIPPING DIM'S

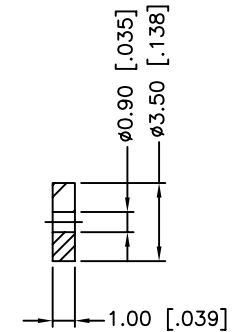
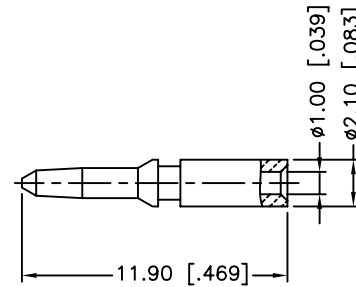
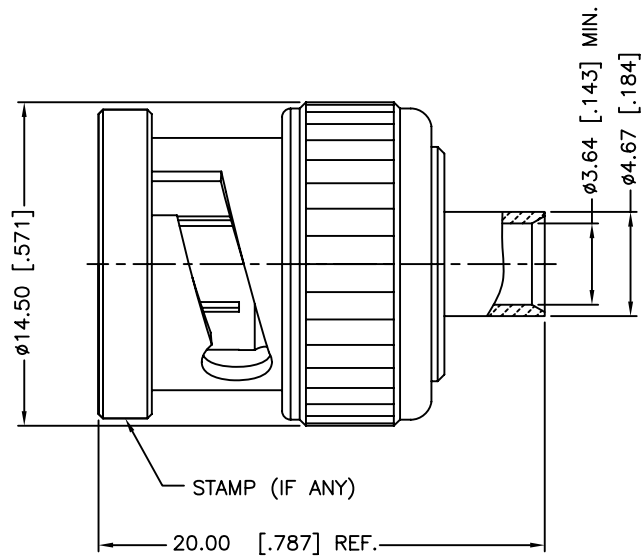

1. CRIMPED CONTACT PIN
HEX. CRIMP SIZE .068"

QTY	DESCRIPTION	MATERIAL	FINISH
1	CONTACT PIN	BRASS	GOLD
1	INSULATOR	PTFE	NATURAL
1	BODY	BRASS	GOLD
1	SHELL	BRASS	NICKEL

UNLESS OTHERWISE SPECIFIED DIMENSIONS ARE IN MILLIMETERS. DIMENSIONS IN [] ARE IN INCHES AND FOR CUSTOMER REFERENCE ONLY.

UNLESS OTHERWISE SPECIFIED TOLERANCES FOR MILLIMETERS ARE:
0.5 - 8mm ± 0.20mm
8 - 30mm ± 0.40mm
30 - 120mm ± 0.50mm

UNLESS OTHERWISE SPECIFIED TOLERANCES FOR INCHES ARE:
.020 - .315 = ± 0.007"
.315 - 1.180 = ± 0.015"
1.180 - 4.724 = ± 0.020"

DO NOT SCALE DRAWING

APPROVALS	DATE
DRAWN M.ZHANG	07/22/11
CHECKED	
ISSUED	
SHEET 1 OF 1	
CAD FILE C:/CONNEX/112551.DWG	

Amphenol Connex			
PART DESCRIPTION BNC DIRECT SOLDER PLUG (FOR .141" SEMI RIGID CABLE)			
PART NO. 112551			
DWG. NO.	112551.DWG	REV. D	SCALE NA