

COMPONENT SPECIFICATION

M80-7XX SERIES CONNECTORS - THREE ROW

JUN 2010

CONTENTS:

SECTION	TITLE	PAGE
1	Description of Connector and Intended Application	2
2	Marking of Connector and/or Package	2
3	Ratings	2
Appendix 1	Ordering Information	4
Appendix 2	Contact Orientations	5
Appendix 3	Instructions for the use of connectors fitted with Jackscrews	6
Appendix 4	Gauges	7

APPENDICES NOTES:

1. Third angle projection is used where projected views are shown.
2. All dimensions are in millimetres.
3. For explanation of dimensions, etc. see BS308.
4. Unless otherwise stated, all dimensions are maxima.

PREPARED BY:.....S. McCullagh	<u>ISSUE</u>	<u>C/NOTE</u>	<u>DATE</u>
	01	----	02.09.85
APPROVED BY:.....R. Adde.....	02	2076	02.09.92
	03	2480	26.11.93
	04	3527	10.04.97
	05	8132	25.08.04
	06	9549	15.11.06
	07	10269	21.01.09
	08	10836	21.06.10

COMPONENT SPECIFICATION (CONTINUED)**1. DESCRIPTION OF CONNECTOR AND INTENDED APPLICATION.**

A range of 2mm pitch male and female rectangular, fully shrouded unsealed connectors with replaceable contacts for interconnecting board to board and board to wire. The range covers female connectors suitable for crimp or through board termination and male connectors available for straight or 90° through-board termination. The connectors are provided with a range of contact terminations (as shown in Appendix 1) which are gold or gold/tin plated. The contact zone of gold plated contacts is hard acid gold of 98% purity.

The connector is intended for use as a connector in high packing density electronic equipment. Low and high frequency contacts can be supplied. The connector is polarised to prevent mis-matching and can be produced with a jackscrew feature as required.

2. MARKING OF THE CONNECTOR AND/OR PACKAGE (ORDER CODE).

The marking (order code) shall appear on the package and shall be of the following style:

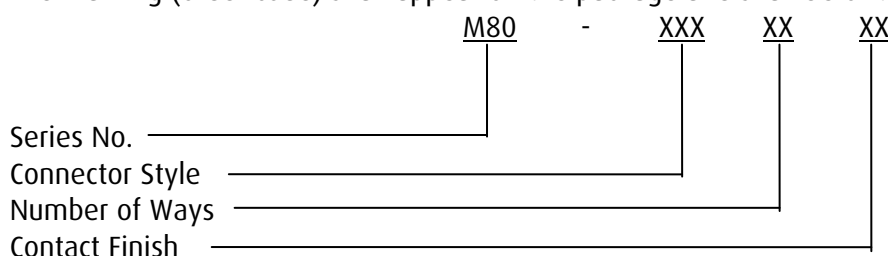

For details of styles, numbers of ways and finishes see Appendix 1 of this Specification.

The batch code shall appear on the package and shall be of the following style:

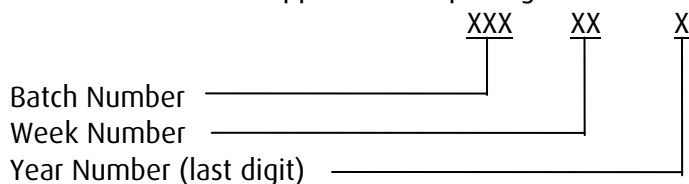
**3. RATINGS.****3.1. ELECTRICAL CHARACTERISTICS.**

Standard Contacts:

Current per individual contact* at an ambient temperature of 25°C	3.3A max
Current per individual contact* at an ambient temperature of 85°C	2.6A max
Current per contact through all contacts at an ambient temperature of 25°C	3.0A max
Current per contact through all contacts at an ambient temperature of 85°C	2.2A max

Power Contacts:

Current per individual contact* at an ambient temperature of 25°C	16.5A max
Current per individual contact* at an ambient temperature of 85°C	13.0A max
Current per contact through all contacts at an ambient temperature of 25°C	15.0A max
Current per contact through all contacts at an ambient temperature of 85°C	11.0A max

(* = When only one contact per connector is electrically loaded)

COMPONENT SPECIFICATION (continued)**3. RATINGS (continued).****3.1. ELECTRICAL CHARACTERISTICS (CONTINUED).**

Creepage path contact-to-contact	0.35mm min
Air gap contact-to-contact	0.35mm min
Working voltage.....	120V DC or AC peak (sea level)
Voltage proof	360V DC nominal or AC peak (sea level)
Maximum contact resistance (initially)	20 mΩ
Maximum contact resistance (after conditioning)	25 mΩ
Minimum insulation resistance (initially)	1000 MΩ
Minimum insulation resistance (hot after conditioning)	100 MΩ

3.2. ENVIRONMENTAL CHARACTERISTICS.

Environmental classification	55/125/56
Low air pressure severity	300 mbar
Vibration severity	10Hz to 2000 Hz at 0.75mm / 98m/s ² (10g), duration 6 hours
Bump severity	390m/s ² (40g), + 106 crimps
Shock severity	981m/s ² (100g) for 6 ns
Acceleration severity	490m/s ² (50g)

3.3. MECHANICAL CHARACTERISTICS.

Durability	500 operations
High temperature, long term (current as in 3.1.)	1000 hours at 40°C
High temperature, short term (no electrical load)	250 hours at 85°C
Contact retention in moulding	10 N min
Crimp contact retention in moulding (after 3 replacements)	10 N min
Contact holding force (after 3 sizings using holding gauge A4.3)	0.2 N min

Insertion and withdrawal forces (without jackscrew fitted)

Number of contact pins	FORCE (N)		
	Engaging (Max)	Separating (Max)	Separating (Min)
27	76	49	5.4
36	101	65	7
45	126	81	9
51	143	92	10
63	177	144	12
6+2	35	23	3
15+2	60	39	5
24+2	86	56	6
30+2	102	66	8
42+2	136	88	10

COMPONENT SPECIFICATION (continued)**3.4. WIRE TERMINATION RANGE.**

Crimp Type	Small Bore	Small Bore	Small Bore	Large Bore	Power	Power
No. & Nominal dia (mm) of wires	7 / 0.125	19 / 0.1	7 / 0.2	19 / 0.15	19 / 0.2	19 / 0.25
A.W.G.	28	26	24	22	20	18
Minimum pull-off force	12.5N	25N	44N	50N	85N	140N
M22520/2-01 Crimp tool setting	6	6	6	6	8	8

APPENDIX 1 - ORDERING INFORMATION.

Connectors are ordered as follows (for detailed order codes see current catalogue):

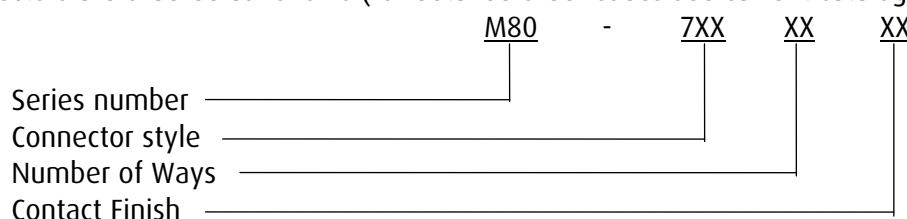
**A1.1. SERIES NUMBER.**

M80 = 2mm pitch Datamate (polarised shrouded). M80 to appear on all orders.

A1.2. CONNECTOR STYLE.

A three-digit number designating connecting style, i.e.:

No.	GENDER	ORIENTATION	TAIL TYPE	CONNECTORS	TERMINATION STYLE	JACKSCREW
700	Male	Vertical	P.C. Tail	Standard	T	Yes
701	Male	Horizontal	P.C. Tail	Standard	L	Yes
702	Male	Vertical	P.C. Tail	Standard	T	No
703	Male	Horizontal	P.C. Tail	Standard	L	No
704	Female	Vertical	P.C. Tail	Standard	T	Yes
705	Female	Crimp	Small Bore	Standard	C	Yes
706	Female	Crimp	Large Bore	Standard	D	Yes
707	Female	Vertical	P.C. Tail	Standard	T	No
708	Female	Crimp	Small Bore	Standard	C	No
709	Female	Crimp	Large Bore	Standard	D	No
710	Male	Vertical	P.C. Tail	Standard+Power	T + P	Yes
711	Male	Horizontal	P.C. Tail	Standard+Power	L + P	Yes
712	Male	Vertical	P.C. Tail	Standard+Power	T + P	No
713	Male	Horizontal	P.C. Tail	Standard+Power	L + P	No
714	Female	Vertical	P.C. Tail	Standard+Power	T + P	Yes
715	Female	Crimp	Small Bore	Standard+Power	C + P	Yes
716	Female	Crimp	Large Bore	Standard+Power	D + P	Yes
717	Female	Vertical	P.C. Tail	Standard+Power	T + P	No
718	Female	Crimp	Small Bore	Standard+Power	C + P	No
719	Female	Crimp	Large Bore	Standard+Power	D + P	No

COMPONENT SPECIFICATION (continued)

Datamate

APPENDIX 1 - ORDERING INFORMATION.(CONTINUED)

The termination style refers to the British Standard method of identifying the different types of connector. This identification follows these rules:

- T.....Throughboard straight PC solder tail
- L.....Throughboard 90° PC solder tail
- C.....Crimp tail (small bore)
- D.....Crimp tail (large bore)
- P.....Power contact

A1.3.NUMBER OF WAYS

Two digits indicating total number of contacts. Standard contacts only available in 27, 36, 45, 51 and 63 ways. Standard contacts plus power contacts available in 6+2, 15+2, 24+2, 30+2 and 42+2 ways (denoted as 06, 15, 24, 30 and 42).

A1.4. CONTACT FINISH.

Finish Code	05	06	T6	22	42
Male Contacts	Gold all over	-	-	Selective Gold	Selective Gold
Female Contacts	Gold clip, Gold shell	Gold clip, Tin shell	Tin clip, Tin shell	-	Tin shell, Gold clip

APPENDIX 2 - CONTACT ORIENTATIONS.

These diagrams show pin numbers with reference to the polarisation feature. They represent male and female connectors, shown looking onto the contact face. The contact designation shown below also appears on the non-mating (wiring) face of the connectors.

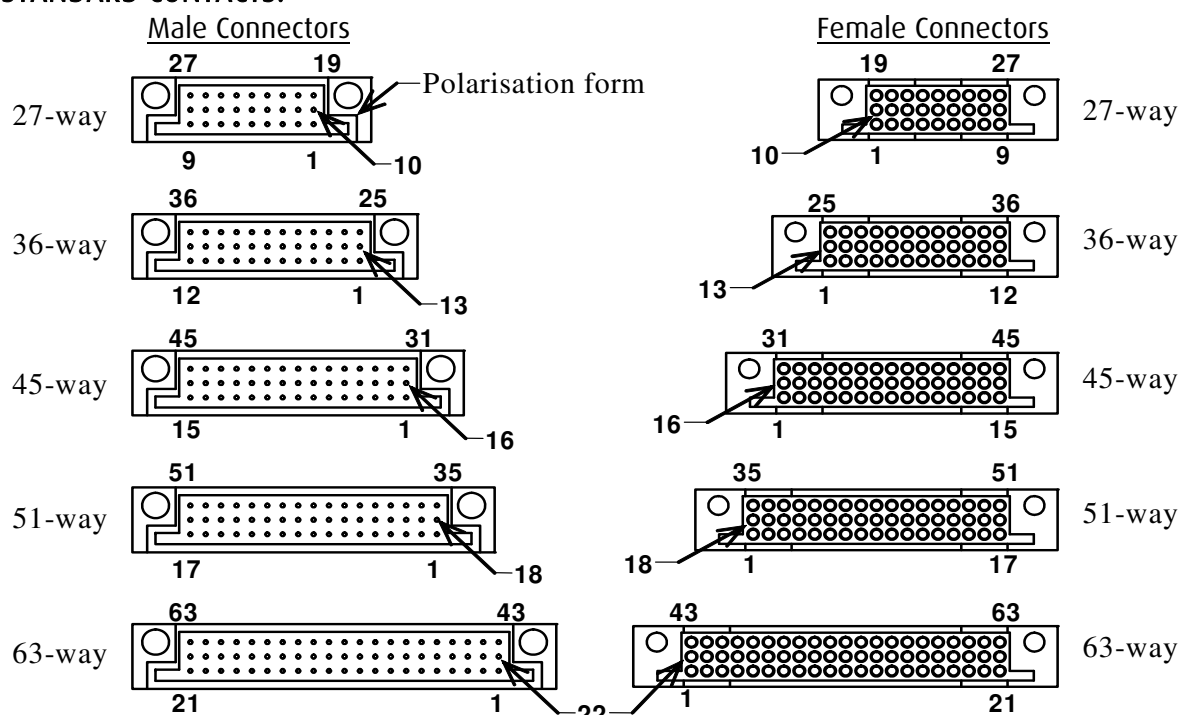
A2.1. STANDARD CONTACTS.

COMPONENT SPECIFICATION (continued)

Datamate

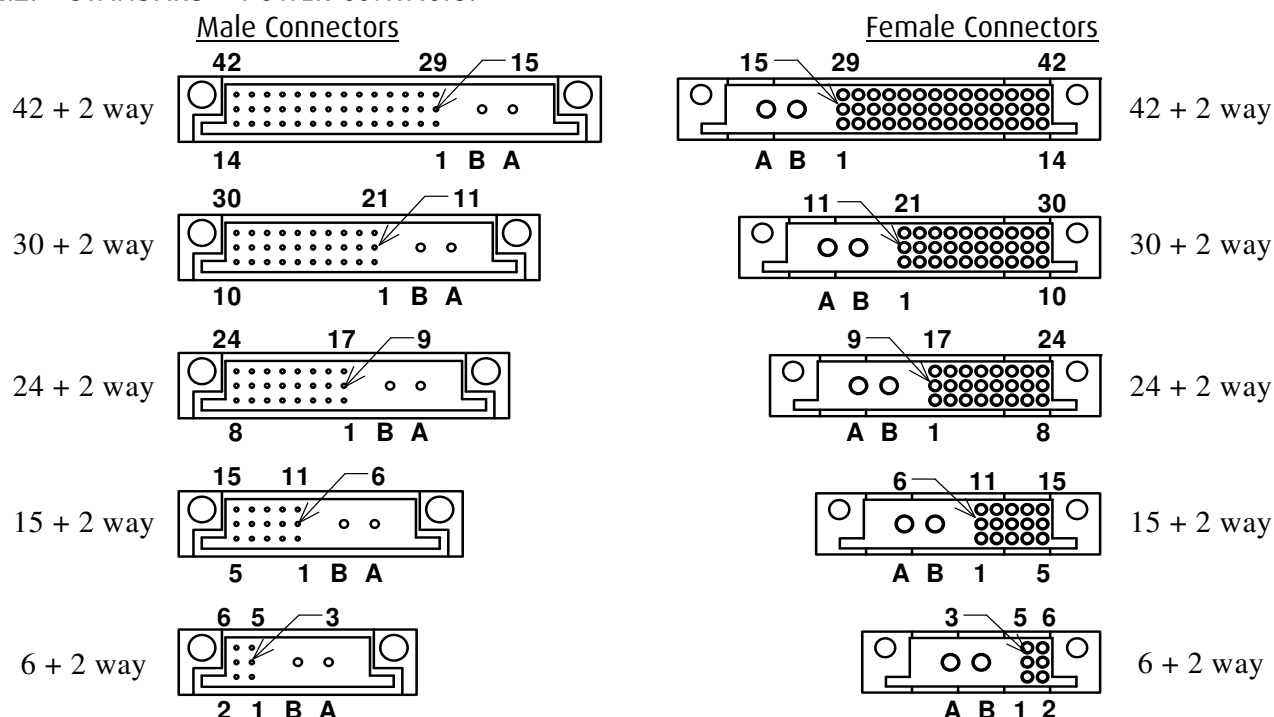
A2.2. STANDARD + POWER CONTACTS.**APPENDIX 3 - INSTRUCTIONS FOR THE USE OF CONNECTORS FITTED WITH JACKSCREWS.**

Connectors are fitted with jackscrews where it is considered necessary to provide mechanical assistance in ensuring a satisfactory engagement and separation of the connector. This may apply in cases where engagement and separation forces are so high as to prevent satisfactory hand engagement, or where access to connector is restricted. Jackscrews also provide a locking feature, preventing the connector from disengaging under adverse conditions.

In order to obtain maximum effectiveness from the jackscrew system, the following rules for their use should be observed.

1. The connector with the fixed jackscrew should be fixed to the mounting board by means of the male thread on the jackscrew, and an M2.5 nut. The nut should be tightened to a torque of $21 \pm 2 \text{ cmN}$.
2. On engaging the two halves of the connector after ensuring correct polarity, lightly push home the floating half until the jackscrews touch. Then, maintaining the pressure, turn one of the floating jackscrews clockwise, by means of a 2mm A/F hexagon key, until it engages with the fixed screw. Repeat with the other screw.

Then screw in each jackscrew, ensuring even loading by applying a maximum of one turn to each screw in sequence until the connector is bottomed. This will be evident by a sudden increase in the torque required on the screw. This torque should not exceed 23 cmN .

3. On disengaging the two halves of the connector turn each of the floating jackscrews anti-clockwise by means of the 2mm A/F hexagon key. Again ensure even loading by turning each screw in sequence for a maximum of one turn until the jackscrew disengages. The connector can then be easily pulled apart.

COMPONENT SPECIFICATION (continued)

APPENDIX 4 - GAUGES.**NOTES:**

1. Material = Steel to BS1407 or equivalent.
2. Gauging surfaces to be hardened/ground to 650 H.V.5 minimum.
3. These gauges to be used for testing fully assembled components only.
4. Ultimate wear limit of 0.005mm is allowable on gauging diameters.
5. Loading force to give 2Nm (Test prod only).

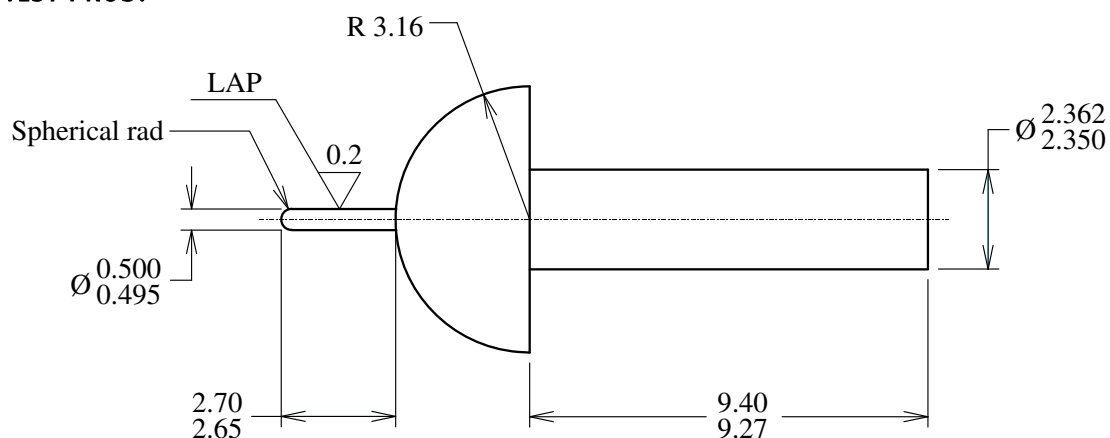
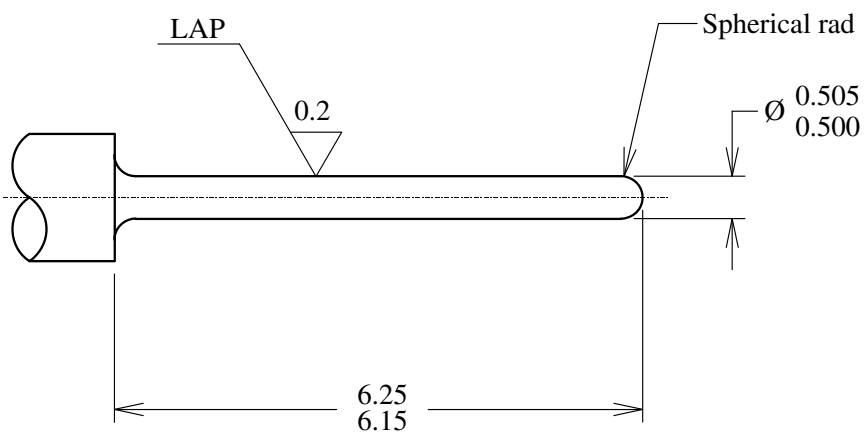
A4.1. TEST PROD.**A4.2. SIZING GAUGE.****A4.3. HOLDING GAUGE (Mass = $20\ +0/-1$ gm).**