

4 PLACES
APPLIES TO ALL CIRCUIT SIZES
BOTH PEGGED AND FLANGED

CIRCUIT SIZE	DIM. "A"	DIM. "B"	DIM. "C"	DIM. "D"
2	.606 (15.40)	N.A.	.213 (5.40)	.354 (9.00)
4	.772 (19.60)	.165 (4.20)	.378 (9.60)	.520 (13.20)
6	.937 (23.80)	.331 (8.40)	.543 (13.80)	.685 (17.40)
8	1.102 (28.00)	.496 (12.60)	.709 (18.00)	.850 (21.60)
10	1.268 (32.20)	.661 (16.80)	.874 (22.20)	1.016 (25.80)
12	1.433 (36.40)	.827 (21.00)	1.039 (26.40)	1.181 (30.00)
14	1.598 (40.60)	.992 (25.20)	1.205 (30.60)	1.346 (34.20)
16	1.764 (44.80)	1.157 (29.40)	1.370 (34.80)	1.512 (38.40)
18	1.929 (49.00)	1.323 (33.60)	1.535 (39.00)	1.677 (42.60)
20	2.094 (53.20)	1.488 (37.80)	1.701 (43.20)	1.843 (46.80)
22	2.260 (57.40)	1.654 (42.00)	1.866 (47.40)	2.008 (51.00)
24	2.425 (61.60)	1.819 (46.20)	2.031 (51.60)	2.173 (55.20)

- NOTES:
- 1) MATERIALS:
HOUSING MATERIAL OPTIONS: SEE CHART FOR SPECIFIC PART
 NYLON, UNFILLED, UL94V-2, COLOR: NATURAL
 NYLON, UNFILLED, UL94V-2, COLOR: BLACK
 NYLON, UNFILLED, UL94V-0, COLOR: NATURAL
 NYLON, UNFILLED, UL94V-0, COLOR: BLACK
 LCP GLASS FILLED, UL94V-0, COLOR: BLACK
 IEC 60335-1, 5TH EDITION GLOW WIRE CAPABLE,
 WITH PRESS FIT PEG -SEE SHEET 3
 TERMINALS: BRASS
 - 2) FINISH (PLATING) OPTIONS: SEE CHART FOR SPECIFIC PART
 "GS" = 0.00076/(.000030) MIN. SELECT GOLD AND
 0.00254/(.0000100) SELECT MATTE TIN OVER
 0.00127/(.000050) MIN. NICKEL
 "MS" = 0.00254/(.000100) MIN. MATTE TIN OVER
 0.00127/(.000050) MIN. NICKEL
 - 3) PRODUCT SPECIFICATION: PS-5556-004 FOR LCP GLASS FILLED MATERIAL,
 PS-5556-001 FOR ALL OTHER MATERIALS.
 - 4) PACKAGING: SEE CHART: BULK PER PK-5569-002
 TRAY PER PK-5569-003(PEGGED) OR PK-5569-004(FLANGES)
 - 5) CIRCUITS SHOWN PROVIDE THE MAKE-FIRST/BREAK-LAST FEATURE.
 SEE CHARTS ON SHEETS 3 & 4 FOR SPECIFIC CIRCUIT LOCATIONS.
 - 6) PART MATES WITH MINI-FIT JR. RECEPTACLE #5557.
 - 7) CONNECTORS ARE NOT TO BE MATED OR UNMATED WHILE CIRCUITS ARE LIVE.
 - 8) PARTS ARE NOT DESIGNED FOR CURRENT SHARING.
 - 9) DISCOLORATION IN THE BANDOLIER CARRIER AREA OF THE PIN IS INHERENT TO
 THE PLATING PROCESS AND IS DUE TO THE MASKING EFFECT OF THE CARRIER.
 THIS DISCOLORATION, IF PRESENT, IS IN A NON-FUNCTIONAL AREA OF THE PIN
 AND WILL NOT EFFECT THE PERFORMANCE OF THE HEADER ASSEMBLY.
 - 10) PART CONFORMS TO CLASS "B" REQUIREMENTS OF COSMETIC SPECIFICATION
 PS-45499-002.
 - 11) FORMING MARKS ARE ACCEPTABLE.
 - 12) CORNER CORE-OUTS ARE OPTIONAL AND MAY OR MAY NOT BE PRESENT.
 - 13) TEXT ON PART IS FOR REFERENCE ONLY. TEXT AND TEXT LOCATION MAY VARY
 DEPENDING ON PART NUMBER AND/OR TOOL.

THIS DRAWING CONTAINS INFORMATION THAT IS PROPRIETARY TO MOLEX ELECTRONIC TECHNOLOGIES, LLC AND SHOULD NOT BE USED WITHOUT WRITTEN PERMISSION

SYMBOLS	DIMENSION UNITS	SCALE	CURRENT REV DESC: ADDED 44130-0049 P/N		
	IN/MM	4:1			
GENERAL TOLERANCES (UNLESS SPECIFIED)	MM	INCH	EC NO: 645384		
	±	±	DRWN: EHAUGERUD 2020/09/15		
4 PLACES	±	±	CHK'D: DSTEIER 2020/09/18		
3 PLACES	±	±	APPR: FSMITH 2020/09/23		
2 PLACES	± 0.38	±	INITIAL REVISION:		
1 PLACE	± 0.38	±	DRWN: POLGAR 1998/01/23		
0 PLACES	±	±	APPR: FSMITH 2011/05/18		
ANGULAR TOL	± 0.5°		THIRD ANGLE PROJECTION		
DRAFT WHERE APPLICABLE MUST REMAIN WITHIN DIMENSIONS			DRAWING SERIES		
			C-SIZE 44130		

DOCUMENT NUMBER		DOC TYPE	DOC PART	REVISION
SD-44130-001		PSD	000	E17
MATERIAL NUMBER	CUSTOMER	SHEET NUMBER		
SEE CHART	GENERAL MARKET	1 OF 5		

HOUSING WITH PEGS

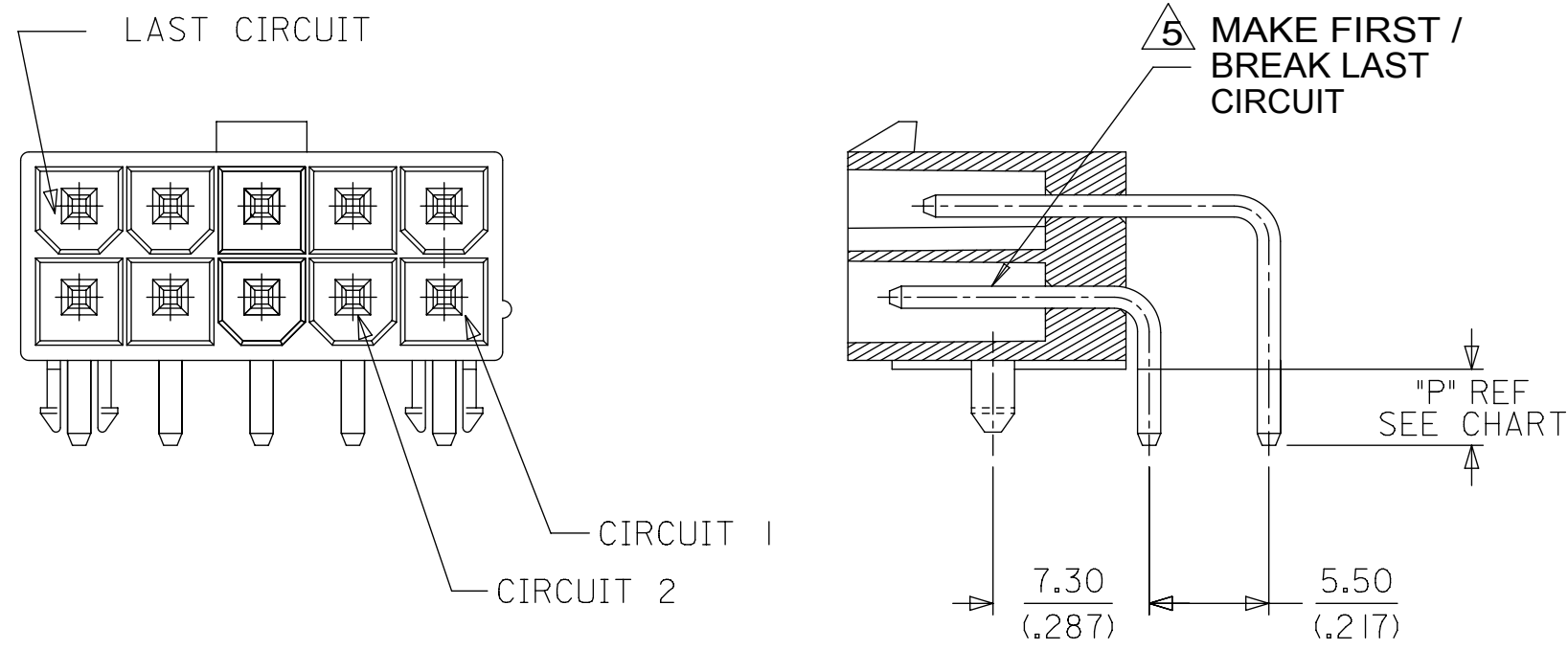

HOUSING WITH FLANGE

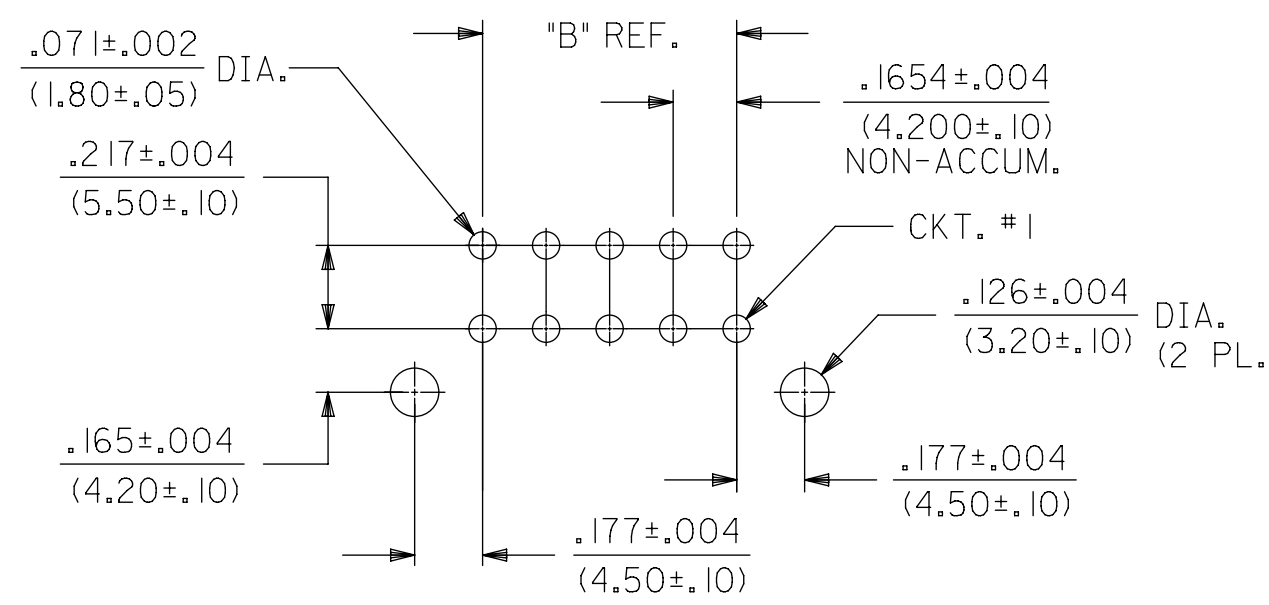
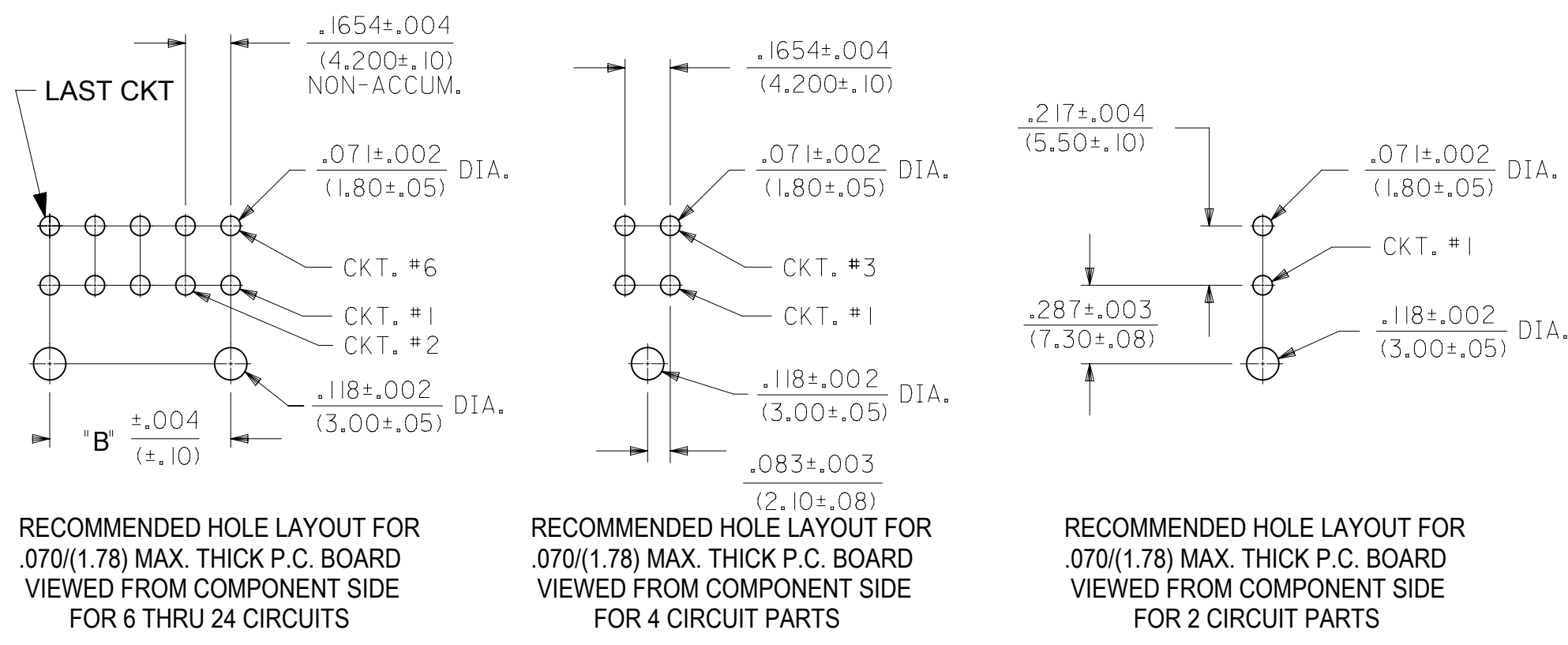
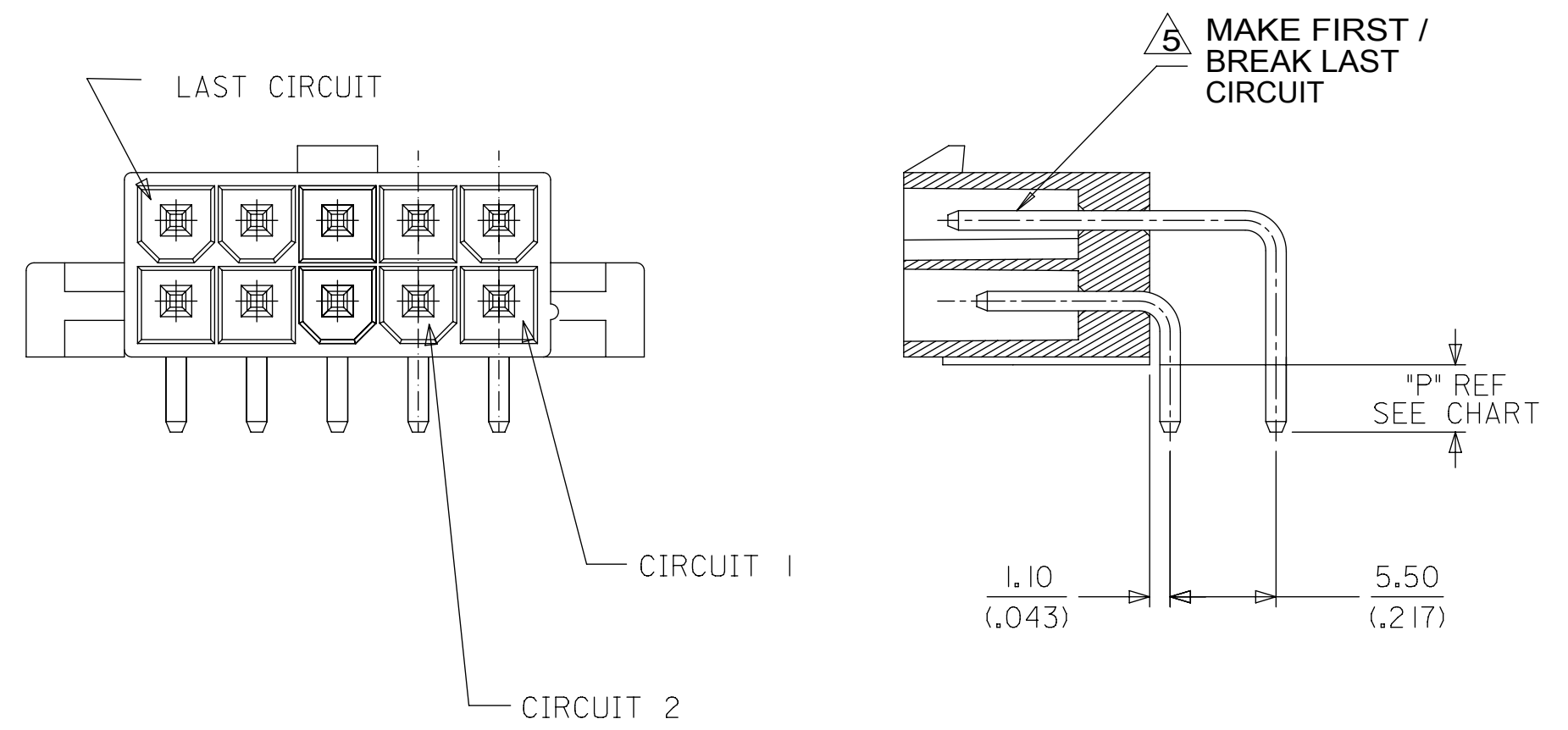

RECOMMENDED HOLE LAYOUT FOR .070/(1.78) MAX. THICK P.C. BOARD VIEWED FROM COMPONENT SIDE FOR 6 THRU 24 CIRCUITS

RECOMMENDED HOLE LAYOUT FOR .070/(1.78) MAX. THICK P.C. BOARD VIEWED FROM COMPONENT SIDE FOR 4 CIRCUIT PARTS

RECOMMENDED HOLE LAYOUT FOR .070/(1.78) MAX. THICK P.C. BOARD VIEWED FROM COMPONENT SIDE FOR 2 CIRCUIT PARTS

RECOMMENDED HOLE LAYOUT FOR .070/(1.78) MAX. THICK P.C. BOARD. (FLANGE MOUNT)

THIS DRAWING CONTAINS INFORMATION THAT IS PROPRIETARY TO MOLEX ELECTRONIC TECHNOLOGIES, LLC AND SHOULD NOT BE USED WITHOUT WRITTEN PERMISSION									
SYMBOLS		DIMENSION UNITS		SCALE		CURRENT REV DESC: ADDED 44130-0049 P/N			
▽ = 0		IN/MM		4:1		molex MINI-FIT JR RIGHT ANGLE HEADER ASSY CUSTOM HEADERS PRODUCT CUSTOMER DRAWING			
▽ = 0		GENERAL TOLERANCES (UNLESS SPECIFIED)							
▽ = 0		MM		INCH					
▽ = 0		±		±					
S = 0		4 PLACES		±		EC NO: 645384			
▽ = 0		3 PLACES		±		DRWN: EHAUGERUD 2020/09/15			
▽ = 0		2 PLACES		± 0.38		CHK'D: DSTEIER 2020/09/18			
▽ = 0		1 PLACE		± 0.38		APPR: FSMITH 2020/09/23			
□ = 0		0 PLACES		±		INITIAL REVISION:			
■ = 0		ANGULAR TOL		± 0.5 °		DRWN: POLGAR 1998/01/23			
▽ = 0		DRAFT WHERE APPLICABLE MUST REMAIN WITHIN DIMENSIONS		THIRD ANGLE PROJECTION		DRAWING		SERIES	
				C-SIZE		44130		APPR: FSMITH 2011/05/18	
DOCUMENT STATUS		P1		RELEASE DATE		2020/09/23 23:07:16		DOCUMENT NUMBER	
								SD-44130-001	
								DOC TYPE	
								PSD	
								DOC PART	
								000	
								REVISION	
								E17	
								MATERIAL NUMBER	
								SEE CHART	
								CUSTOMER	
								GENERAL MARKET	
								SHEET NUMBER	
								2 OF 5	

HOUSING WITH PRESS FIT PEGS

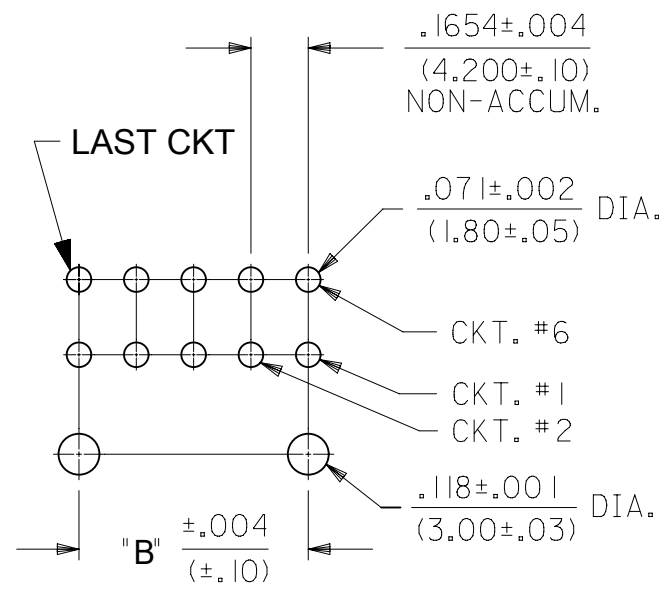
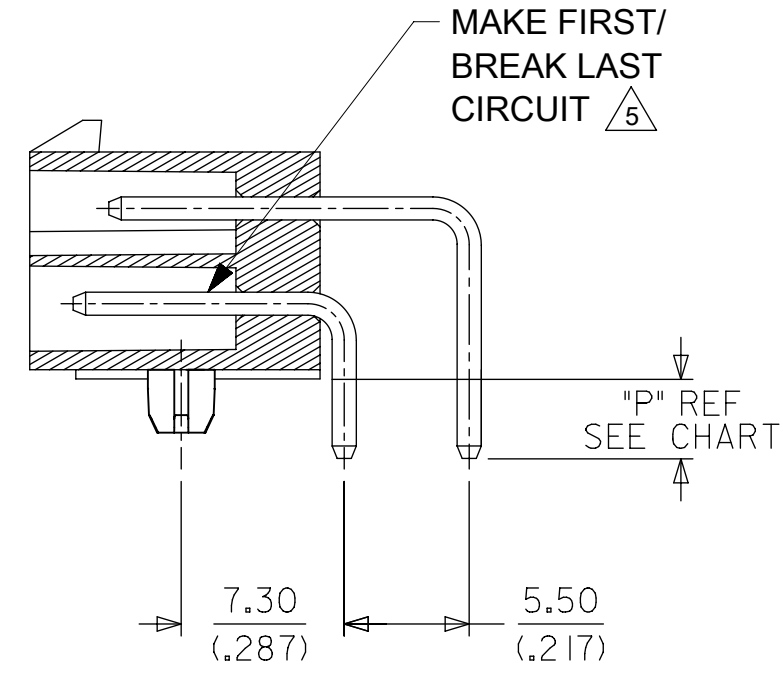
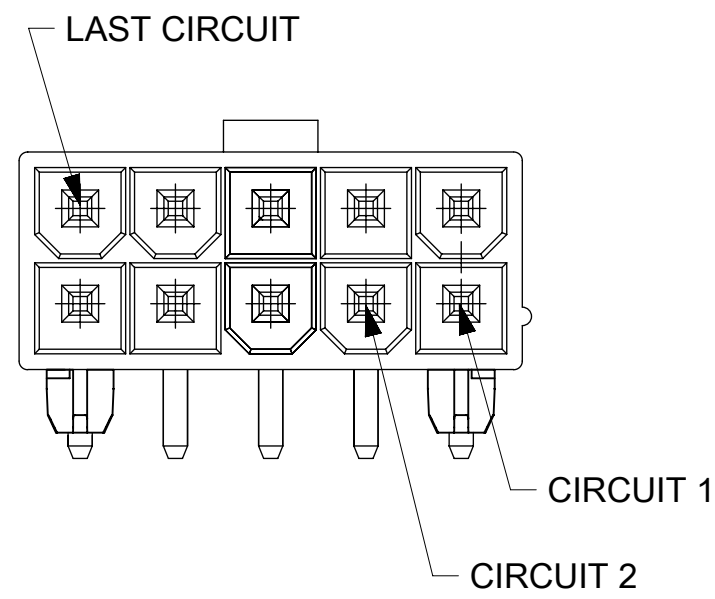

RECOMMENDED HOLE LAYOUT FOR
.070/(1.78) MAX. THICK P.C. BOARD
VIEWED FROM COMPONENT SIDE
FOR 6 THRU 24 CIRCUITS

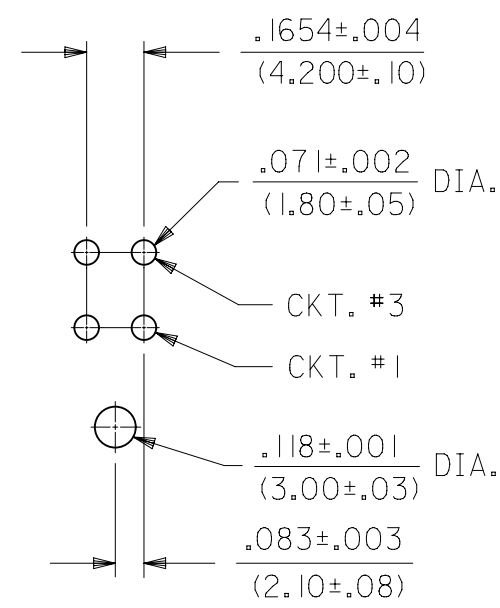

RECOMMENDED HOLE LAYOUT FOR
.070/(1.78) MAX. THICK P.C. BOARD
VIEWED FROM COMPONENT SIDE
FOR 4 CIRCUIT PARTS

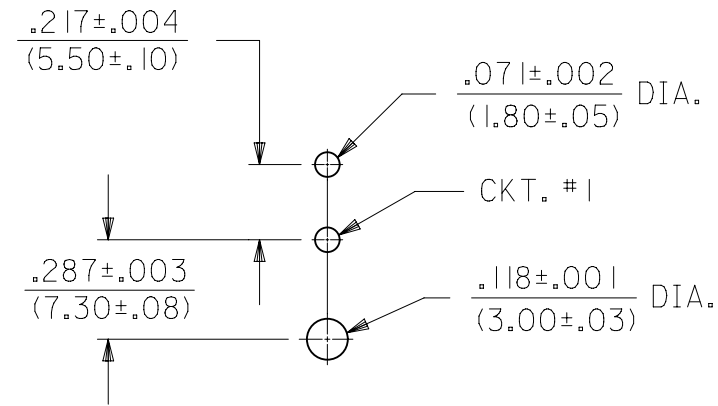

RECOMMENDED HOLE LAYOUT FOR
.070/(1.78) MAX. THICK P.C. BOARD
VIEWED FROM COMPONENT SIDE
FOR 2 CIRCUIT PARTS

SYMBOLS	THIS DRAWING CONTAINS INFORMATION THAT IS PROPRIETARY TO MOLEX ELECTRONIC TECHNOLOGIES, LLC AND SHOULD NOT BE USED WITHOUT WRITTEN PERMISSION									
	DIMENSION UNITS		SCALE		CURRENT REV DESC: ADDED 44130-0049 P/N					
∇ = 0	IN/MM		4:1		molex MINI-FIT JR RIGHT ANGLE HEADER ASSY CUSTOM HEADERS PRODUCT CUSTOMER DRAWING					
∇ = 0	GENERAL TOLERANCES (UNLESS SPECIFIED)									
∇ = 0			MM	INCH	EC NO: 645384 DRWN: EHAUGERUD 2020/09/15 CHK'D: DSTEIER 2020/09/18 APPR: FSMITH 2020/09/23					
S = 0	4 PLACES		±	±	INITIAL REVISION: DRWN: DRWN BY XXXX/XX/XX APPR: APPR BY XXXX/XX/XX					
∇ = 0	3 PLACES		±	±						
∇ = 0	2 PLACES		± 0.38	±	DOCUMENT NUMBER: SD-44130-001 DOC TYPE: PSD DOC PART: 000 REVISION: E17					
∇ = 0	1 PLACE		± 0.38	±						
∇ = 0	0 PLACES		±	±	MATERIAL NUMBER		CUSTOMER		SHEET NUMBER	
∇ = 0	ANGULAR TOL		± 0.5°		THIRD ANGLE PROJECTION		DRAWING		SERIES	
∇ = 0	DRAFT WHERE APPLICABLE MUST REMAIN WITHIN DIMENSIONS				C-SIZE		44130		GENERAL MARKET	

MATERIAL NUMBER	HOUSING MAT'L/COLOR	NO OF CKT	HOUSING OPTION	PKG	FINISH SEE NOTE #2	PIN IDENTIFICATION CODE / CIRCUIT LOCATION (SEE CHART BELOW) V = VOID																							
						CKT 1	CKT 2	CKT 3	CKT 4	CKT 5	CKT 6	CKT 7	CKT 8	CKT 9	CKT 10	CKT 11	CKT 12	CKT 13	CKT 14	CKT 15	CKT 16	CKT 17	CKT 18	CKT 19	CKT 20	CKT 21	CKT 22	CKT 23	CKT 24
44130-0001	NYLON 94V-2/BLACK	06	PEG	TRAY	MS					2																			
44130-0002	NYLON 94V-2/BLACK	08	PEG	TRAY	MS	2																							
44130-0003	NYLON 94V-0/BLACK	08	PEG	TRAY	MS	2																							
44130-0004	NYLON 94V-0/BLACK	06	PEG	TRAY	MS					2																			
44130-0006	NYLON 94V-0/NATURAL	04	PEG	BULK	MS	2	3	2	2																				
44130-0007	NYLON 94V-0/NATURAL	06	PEG	BULK	MS	2			2	2	2																		
44130-0008	NYLON 94V-0/NATURAL	10	FLANGES	BULK	MS	4	4	4	4	4	4	4	4	4															
44130-0009	NYLON 94V-0/NATURAL	06	PEG	TRAY	MS	V			2	2	2																		
44130-0013	NYLON 94V-0/NATURAL	06	FLANGES	TRAY	MS	2	2	2		2	2																		
44130-0015	NYLON 94V-2/NATURAL	24	PEG	TRAY	MS	2	2																			2			
44130-0017	NYLON 94V-0/BLACK	08	PEG	TRAY	MS		2																						
44130-0024	NYLON 94V-0/NATURAL	08	PEG	BULK	GS	2	2	5	2	2	5	2	2																
44130-0026	NYLON 94V-2/NATURAL	04	PEG	BULK	MS	8	8	8	8																				
44130-0027	NYLON 94V-0/NATURAL	02	PEG	BULK	MS	5	5																						
44130-0028	NYLON 94V-0/NATURAL	04	PEG	BULK	MS	8	8	8	8																				
44130-0030	NYLON 94V-0/NATURAL	06	PEG	TRAY	GS	2	1	2	2	2	2																		
44130-0031	NYLON 94V-0/NATURAL	08	PEG	BULK	MS	9	9	9	9	9	9	9																	

PIN ID	MATING CONFIGURATION	DIM P REF (PCB TAIL LENGTH)	PIN ID	MATING CONFIGURATION	DIM P (PCB TAIL LENGTH)
2	STANDARD MATING	3.5 (.14)			
3	MAKE FIRST/BREAK LAST (LONGER PIN)	4.9 (.19)			
4	STANDARD MATING	6.0 (.24)			
5	MAKE FIRST/BREAK LAST (LONGER PIN)	4.2 (.17)			
6	STANDARD MATING	4.2 (.17)			
8	STANDARD MATING	5.3 (.21)			

SYMBOLS	THIS DRAWING CONTAINS INFORMATION THAT IS PROPRIETARY TO MOLEX ELECTRONIC TECHNOLOGIES, LLC AND SHOULD NOT BE USED WITHOUT WRITTEN PERMISSION									
	DIMENSION UNITS		SCALE		CURRENT REV DESC: ADDED 44130-0049 P/N					
▽ = 0	IN/MM		1:1		molex MINI-FIT JR RIGHT ANGLE HEADER ASSY CUSTOM HEADERS PRODUCT CUSTOMER DRAWING					
▽ = 0	GENERAL TOLERANCES (UNLESS SPECIFIED)									
▽ = 0			MM	INCH	EC NO: 645384 DRWN: EHAUGERUD 2020/09/15 CHK'D: DSTEIER 2020/09/18 APPR: FSMITH 2020/09/23					
▽ = 0	4 PLACES ±				INITIAL REVISION: DRWN: POLGAR 1998/01/23 APPR: FSMITH 2011/05/18					
▽ = 0	3 PLACES ±									
▽ = 0	2 PLACES ± 0.38 ±				DOCUMENT NUMBER: SD-44130-001 DOC TYPE: PSD DOC PART: 000 REVISION: E17					
▽ = 0	1 PLACE ± 0.38 ±									
▽ = 0	0 PLACES ±				MATERIAL NUMBER: SEE CHART CUSTOMER: GENERAL MARKET SHEET NUMBER: 4 OF 5					
▽ = 0	ANGULAR TOL ± 0.5 °									
▽ = 0	DRAFT WHERE APPLICABLE MUST REMAIN WITHIN DIMENSIONS				THIRD ANGLE PROJECTION		DRAWING: C-SIZE		SERIES: 44130	

MATERIAL NUMBER	HOUSING MAT'L/COLOR	NO OF CKT	HOUSING OPTION	PKG	FINISH SEE NOTE #2	PIN IDENTIFICATION CODE / CIRCUIT LOCATION (SEE CHART BELOW)																															
						CKT 1	CKT 2	CKT 3	CKT 4	CKT 5	CKT 6	CKT 7	CKT 8	CKT 9	CKT 10	CKT 11	CKT 12	CKT 13	CKT 14	CKT 15	CKT 16	CKT 17	CKT 18	CKT 19	CKT 20	CKT 21	CKT 22	CKT 23	CKT 24								
44130-0032	NYLON 94V-0/NATURAL	16	PEG	TRAY	MS	8	8	8	8	8	8	8	8	8	8	8	8	8	8	8																	
44130-0036	NYLON 94V-2/NATURAL	06	PEG	TRAY	MS	2	1	2	2	1	2																										
44130-0037	NYLON 94V-0/NATURAL	06	PEG	TRAY	MS	2	V	2	2	V	2																										
44130-0038	NYLON 94V-0/NATURAL	10	PEG	TRAY	MS	2	V	2	V	2	2	V	2	V	2																						
44130-0039	NYLON 94V-0/NATURAL	04	PEG	TRAY	MS	1	2	2	2																												
44130-0040	NYLON 94V-0/NATURAL	04	PEG	TRAY	MS	2	1	2	2																												
44130-0041	NYLON 94V-0/NATURAL	06	PEG	TRAY	GS	2	V	1	2	V	2																										
44130-0043	NYLON 94V-0/NATURAL	24	FLANGES	TRAY	MS	V	2	V	2	V	2	V	2	V	2	V	2	2	V	2	V	2	V	2	V	2	V	2	V	2	V	2	V	2	V		
44130-0044 (N)	LCP 94V-0/BLACK	24	PRESSFIT PEGS	TRAY	MS	V	2	V	2	V	2	V	2	V	2	V	2	2	V	2	V	2	V	2	V	2	V	2	V	2	V	2	V	2	V		
44130-0045	NYLON 94V-0/NATURAL	24	PEG	TRAY	MS	V	2	V	2	V	2	V	2	V	2	V	2	2	V	2	V	2	V	2	V	2	V	2	V	2	V	2	V	2	V		
44130-0046	NYLON 94V-0/NATURAL	24	PEG	TRAY	GS	V	2	V	2	V	2	V	2	V	2	V	2	2	V	2	V	2	V	2	V	2	V	2	V	2	V	2	V	2	V		
44130-0047	NYLON 94V-0/NATURAL	10	PEG	TRAY	GS	2	V	2	V	2	V	2	V	2	V																						
44130-0048	LCP 94V-0/BLACK	08	PRESSFIT PEGS	TRAY	MS	5	5	5	5	5	5	5	5																								
44130-0049	LCP 94V-0/BLACK	06	PRESSFIT PEGS	TRAY	GS	1	1	1	1	2	1																										

N= NOT TOOLED	PIN ID	MATING CONFIGURATION	DIM PREF (PCB TAIL LENGTH)
	1	MAKE FIRST/BREAK LAST (LONGER PIN)	3.5 (.14)
	2	STANDARD MATING	3.5 (.14)
	3	MAKE FIRST/BREAK LAST (LONGER PIN)	4.9 (.19)
	4	STANDARD MATING	6.0 (.24)
	5	MAKE FIRST/BREAK LAST (LONGER PIN)	4.2 (.17)
	6	STANDARD MATING	4.2 (.17)
	8	STANDARD MATING	5.3 (.21)

SYMBOLS = 0 = 0 = 0 = 0 = 0 = 0 = 0 = 0	THIS DRAWING CONTAINS INFORMATION THAT IS PROPRIETARY TO MOLEX ELECTRONIC TECHNOLOGIES, LLC AND SHOULD NOT BE USED WITHOUT WRITTEN PERMISSION <small>DIMENSION UNITS</small> IN/MM <small>SCALE</small> 1:1		CURRENT REV DESC: ADDED 44130-0049 P/N EC NO: 645384 DRWN: EHAUGERUD 2020/09/15 CHK'D: DSTEIER 2020/09/18 APPR: FSMITH 2020/09/23		 MINI-FIT JR RIGHT ANGLE HEADER ASSY CUSTOM HEADERS PRODUCT CUSTOMER DRAWING DOCUMENT NUMBER: SD-44130-001 DOC TYPE: PSD DOC PART: 000 REVISION: E17 MATERIAL NUMBER: SEE CHART CUSTOMER: GENERAL MARKET SHEET NUMBER: 5 OF 5
	<small>GENERAL TOLERANCES (UNLESS SPECIFIED)</small> 4 PLACES ± ± 3 PLACES ± ± 2 PLACES ± 0.38 ± 1 PLACE ± 0.38 ± 0 PLACES ± ± ANGULAR TOL ± 0.5 °		INITIAL REVISION: DRWN: POLGAR 1998/01/23 APPR: FSMITH 2011/05/18 <small>DRAFT WHERE APPLICABLE MUST REMAIN WITHIN DIMENSIONS</small>		