

FEATURES

- 100 mm² Square Active Area
- Responsivity @ 3 nm 0.16 A/W
- Detection Range 1 nm to 12 nm
- Shipped with Protective Cover

Electro-Optical Characteristics at 25°C

Parameters	Test Conditions	Min	Typ	Max	Units
Active Area	10 mm x 10 mm		100		mm ²
Responsivity	@ 3 nm		0.16		A/W
Shunt Resistance, R _{sh}	@ ±10 mV	20			Ohms
Reverse Breakdown Voltage, V _R	I _R = 1 µA	5	10		Volts
Capacitance, C	V _R = 0 V		10	44	nF

Thermal Parameters

Storage and Operating Temperature Range	Units
Ambient	-10° to 40°C
Nitrogen or Vacuum	-20 to 80°C
Lead Soldering Temperature*	260°C

*0.080" from case for 10 seconds.

Typical Responsivity at 25°C

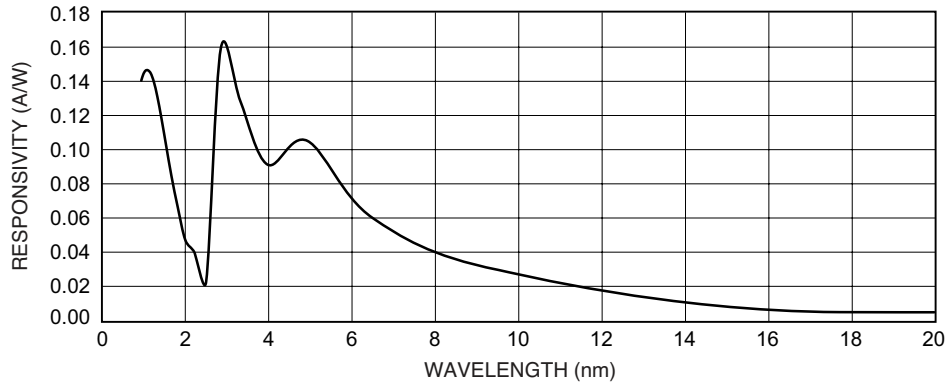

Package Information

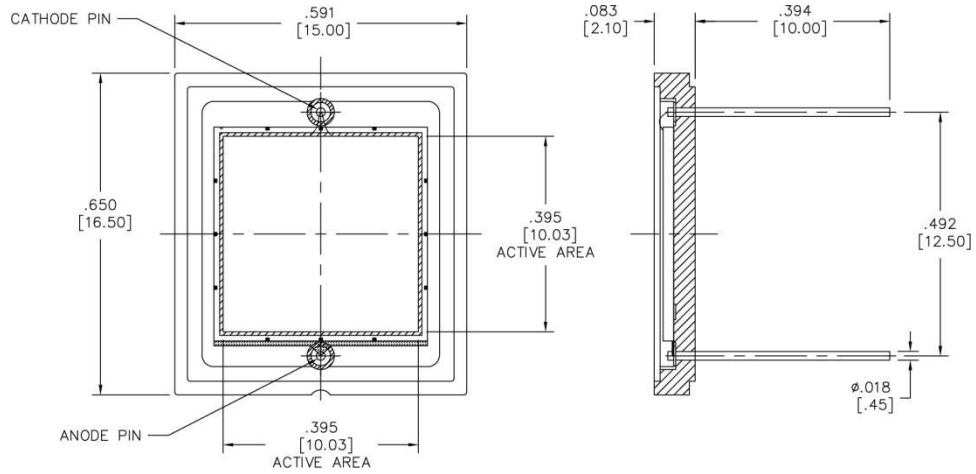

Dimensions are in inch [metric] units.

Specifications are subject to change without prior notice.