

THIS DRAWING IS UNPUBLISHED. RELEASED FOR PUBLICATION
 © COPYRIGHT 20 BY - ALL RIGHTS RESERVED.

REVISIONS					
P	LTR	DESCRIPTION	DATE	DWN	APVD
E1		REVISED PER ECR-16-011494	21JUN2017	NK	CX
E2		ECO-19-006502	25APR2019	AP	WS

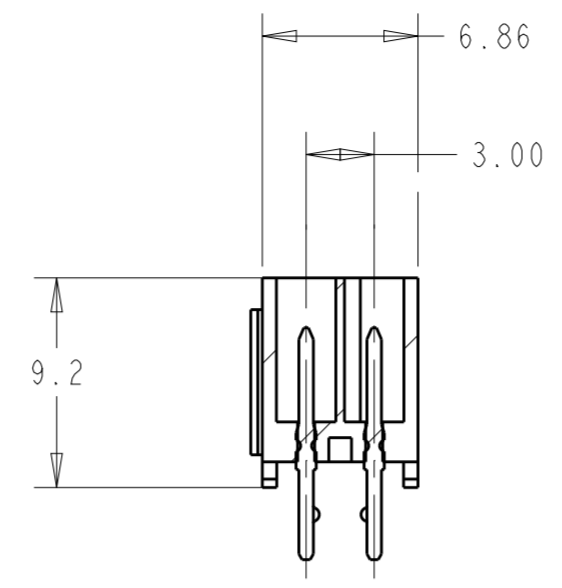

SECTION Z-Z

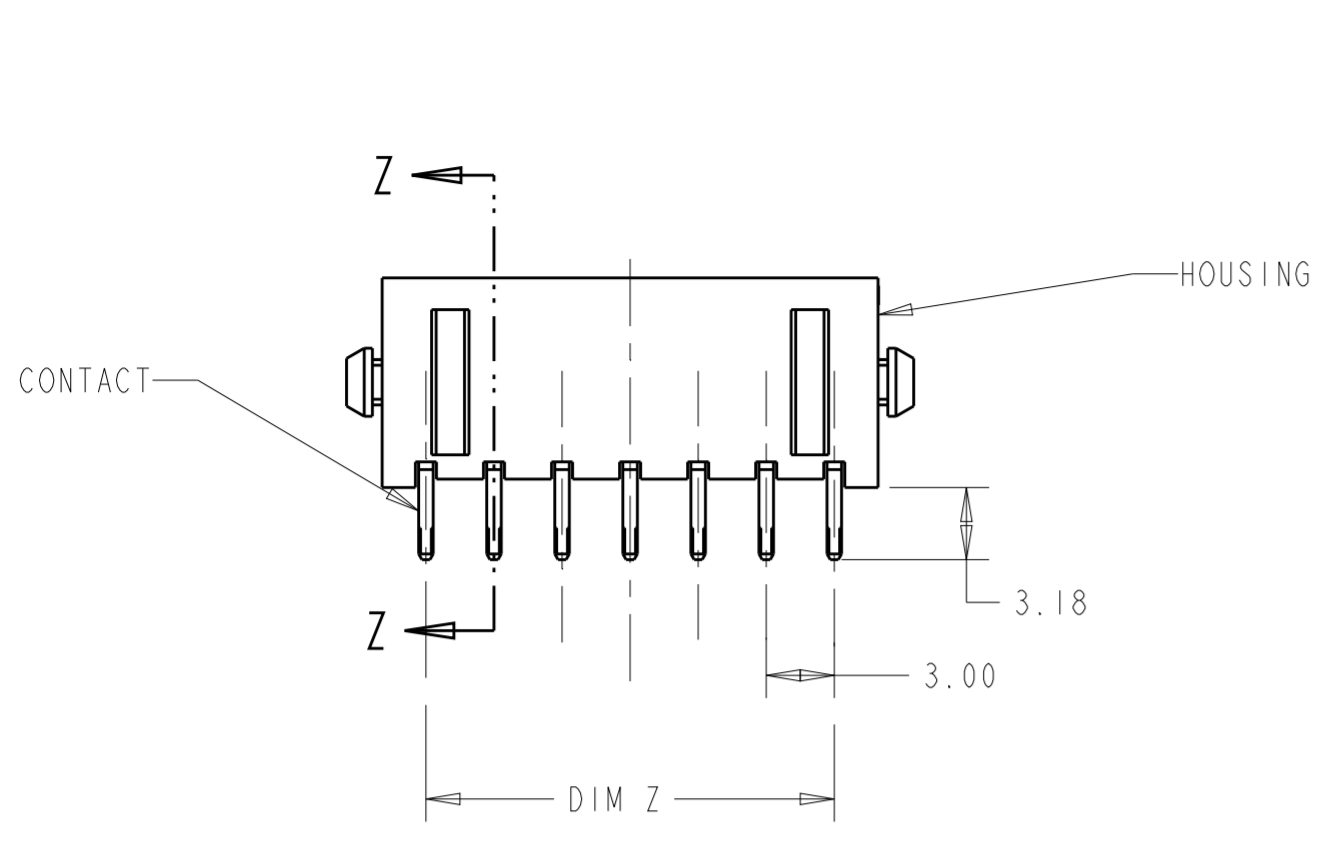
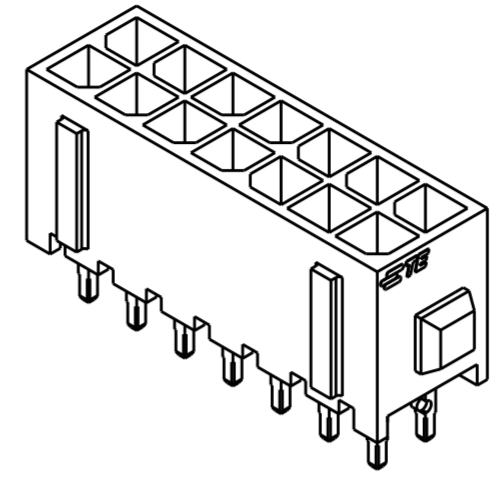

3 DIMENSIONAL MODEL

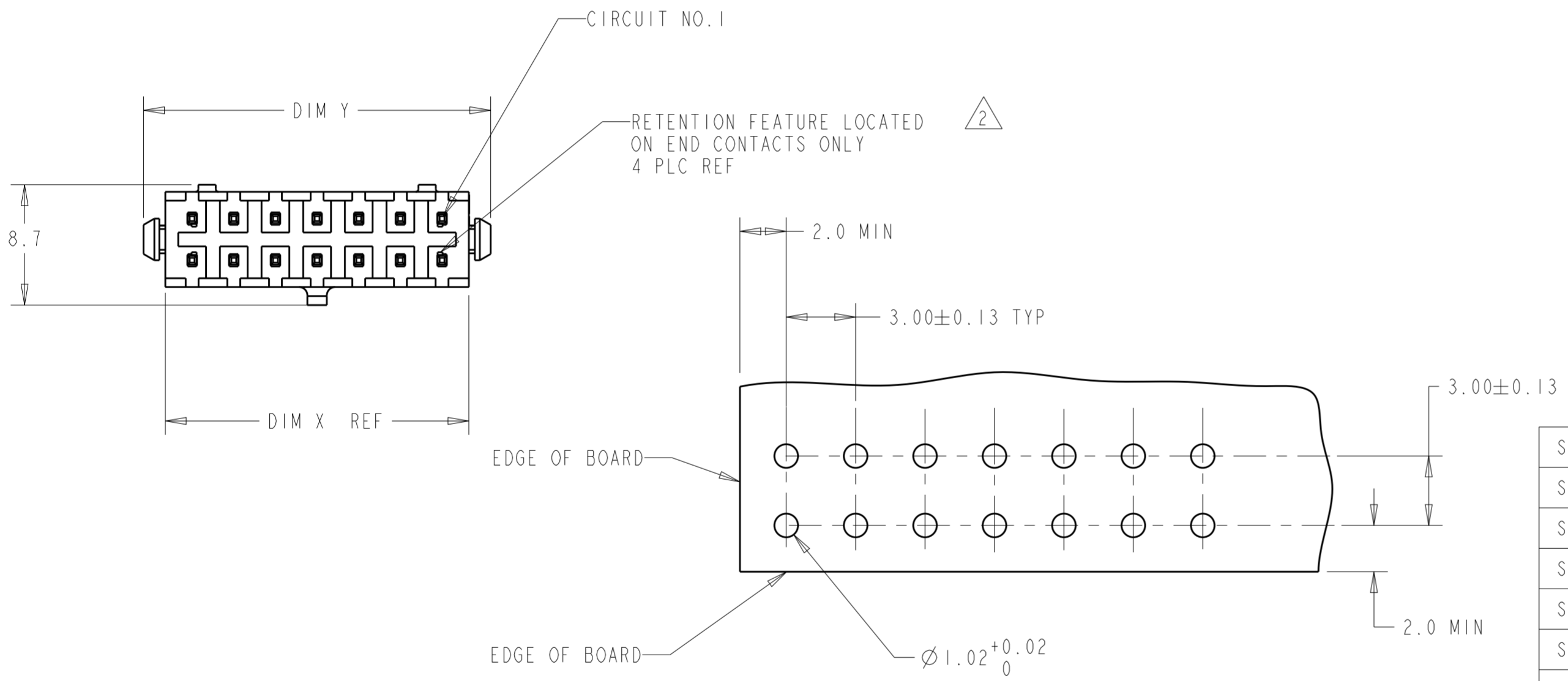

- 1 MATERIAL: HOUSING - NYLON, UL 94V-0, BLACK.
CONTACT - BRASS.
0.00038 MINIMUM GOLD OVER 0.00254
MINIMUM NICKEL ON MATING AREA. 0.00254
TIN-LEAD MINIMUM OVER 0.00254 NICKEL
MINIMUM ON SOLDER TAILS.
- 2 MAXIMUM INSERTION 20 LBS.
- 3 RECOMMENDED BOARD THICKNESS 1.57.
- 4 MATERIAL: HOUSING - NYLON, UL 94V-0, BLACK.
CONTACT - BRASS.
0.00038 MINIMUM GOLD OVER 0.00254
MINIMUM NICKEL ON MATING AREA. 0.00254
MATTE TIN MINIMUM OVER 0.00254 NICKEL
MINIMUM ON SOLDER TAILS.

RECOMMENDED MOUNTING HOLE PATTERN SCALE 5:1

FINISH	DIM Y	DIM Z	DIM X	NO. OF POSN.	PART NUMBER
4	40.00	33.00	36.86	24	5-794631-4
4	37.00	30.00	33.86	22	5-794631-2
4	34.00	27.00	30.86	20	5-794631-0
4	31.00	24.00	27.86	18	4-794631-8
4	28.00	21.00	24.86	16	4-794631-6
4	25.00	18.00	21.86	14	4-794631-4
4	22.00	15.00	18.86	12	4-794631-2
4	19.00	12.00	15.86	10	4-794631-0
4	16.00	9.00	12.86	8	3-794631-8
4	13.00	6.00	9.86	6	3-794631-6
4	10.00	3.00	6.86	4	3-794631-4
4	7.00	-	3.86	2	3-794631-2
1	40.00	33.00	36.86	24	2-794631-4
1	37.00	30.00	33.86	22	2-794631-2
1	34.00	27.00	30.86	20	2-794631-0
1	31.00	24.00	27.86	18	1-794631-8
1	28.00	21.00	24.86	16	1-794631-6
1	25.00	18.00	21.86	14	1-794631-4
1	22.00	15.00	18.86	12	1-794631-2
1	19.00	12.00	15.86	10	1-794631-0
1	16.00	9.00	12.86	8	794631-8
1	13.00	6.00	9.86	6	794631-6
1	10.00	3.00	6.86	4	794631-4
1	7.00	-	3.86	2	794631-2

THIS DRAWING IS A CONTROLLED DOCUMENT.

DIMENSIONS: mm [INCHES]	TOLERANCES UNLESS OTHERWISE SPECIFIED: 0 PLC ± 1 PLC ± 2 PLC ±0.20 [0.008] 3 PLC ± 4 PLC ± ANGLES ± FINISH	DWN B. HAYMAKER 16AUG99 CHK K. COBLE 16AUG99 APVD K. COBLE 16AUG99	TE Connectivity		
MATERIAL	SEE TABLE	PRODUCT SPEC 108-1836 APPLICATION SPEC 114-13000 WEIGHT -	NAME VERTICAL HEADER ASSEMBLY, THRU HOLE, 15 GOLD, DUAL ROW, MICRO MATE-N-LOK™ SIZE A2 CAGE CODE 00779 DRAWING NO. C-794631 RESTRICTED TO - CUSTOMER DRAWING SCALE 3:1 SHEET 1 OF 1 REV E2		