

THIS DRAWING IS UNPUBLISHED. RELEASED FOR PUBLICATION. ALL RIGHTS RESERVED.

REVISIONS				
P	LTR	DESCRIPTION	DATE	DWN APVD
	W1	PART STATUS UPDATED IN PART LIST TABLE	07FEB2018	SD PS

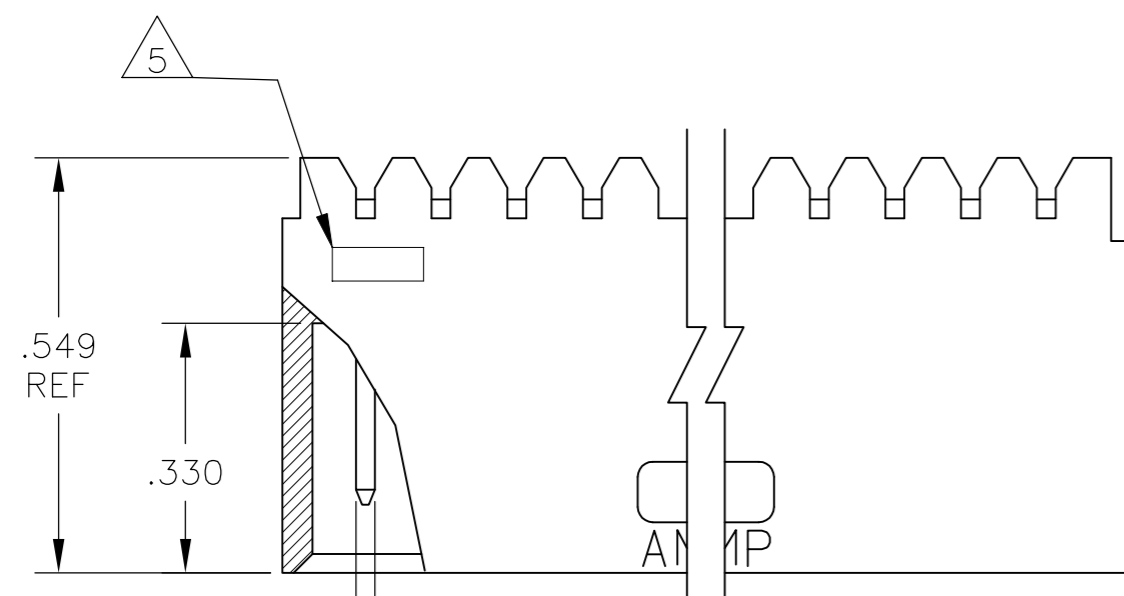

$.025 \pm .001$ TYP
 $\phi .015 \text{ (M)}$ TYP AT POST TIPS

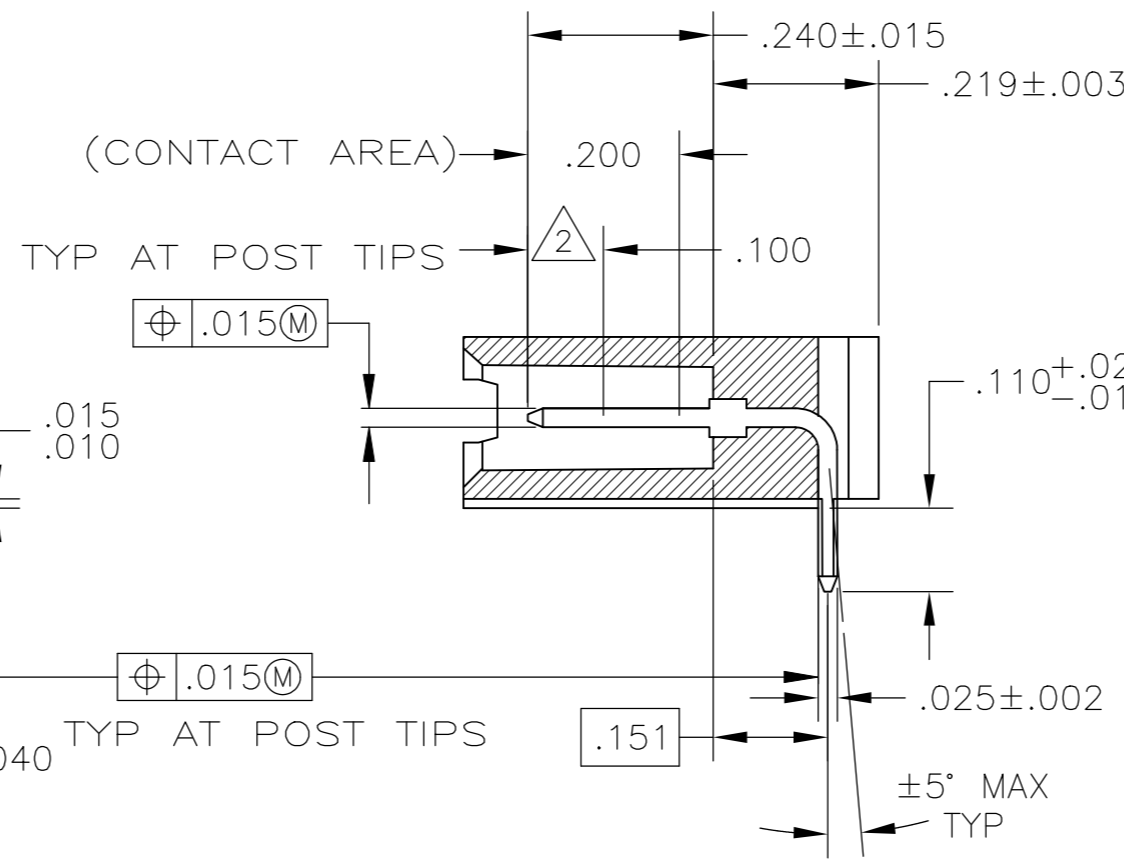
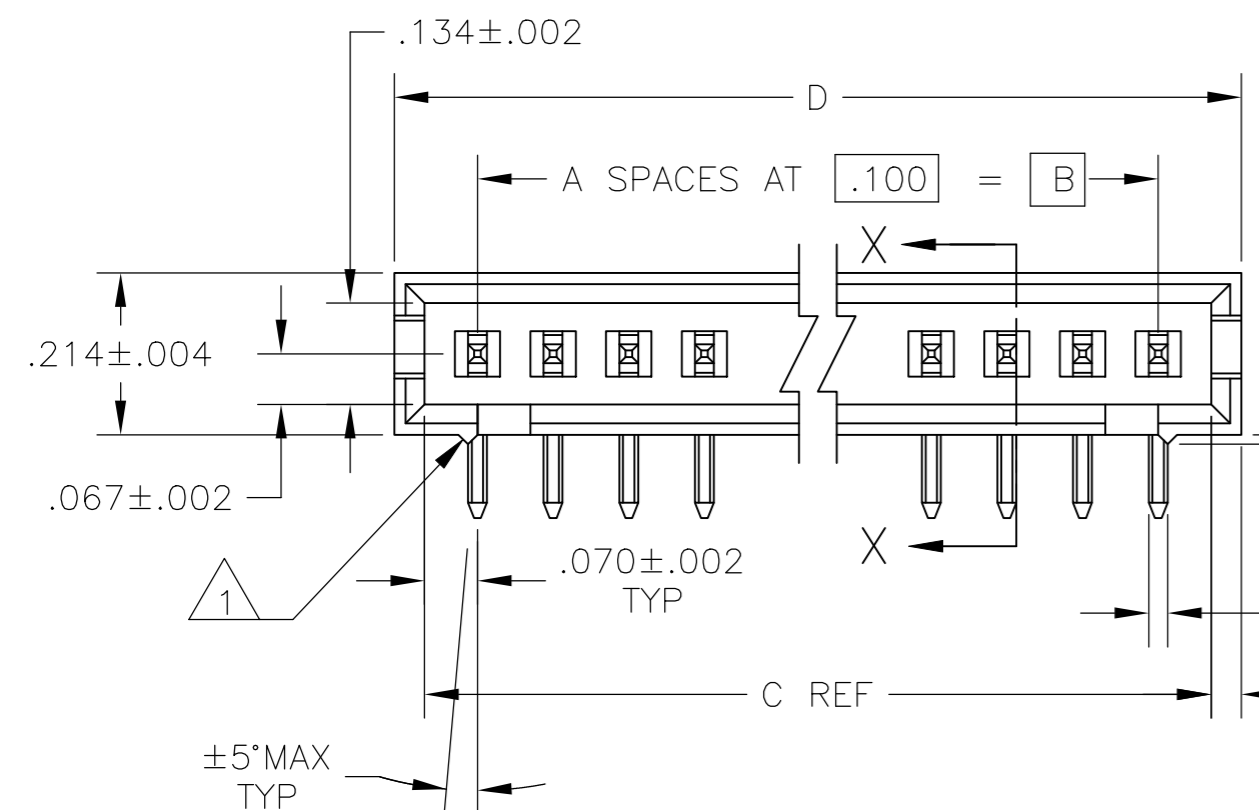

SECTION X-X

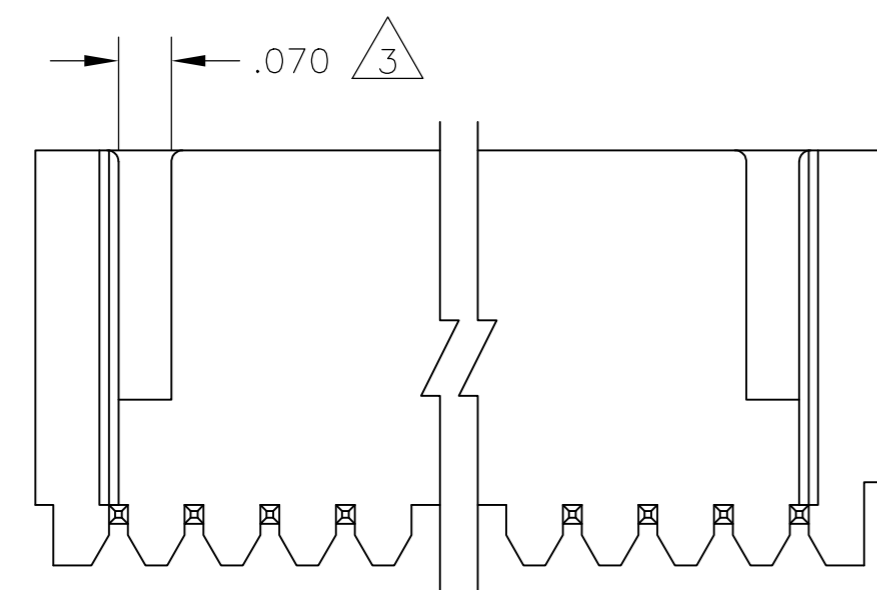

$B \pm .003$
 $.100 \pm .003$ TYP TOLERANCE NON-CUMULATIVE

$\phi .035 \pm .003$ TYP

RECOMMENDED HOLE LAYOUT FOR MANUAL INSERTION

- 1 STANDOFFS: UP TO 9 POS-(2 REQD) ON THE OUTSIDE ENDS OF THE HOUSING 10 TO 19 POS-(3 REQD) TWO ON THE OUTSIDE ENDS AND ONE CENTERED ON THE HOUSING. 19 POS AND LARGER-(4 REQD) TWO ON THE OUTSIDE ENDS AND TWO SPACED EVENLY WITHIN THE REMAINING LENGTH OF THE HOUSING.
- 2 POINT OF MEASUREMENT FOR PLATING THICKNESS.
- 3 FOR 3 POS (3--4 & 3--9 ONLY) ONE SLOT, .215 WIDE.
- 4 INDICATED PARTS ARE PACKAGED IN "GANG-OF-TUBES".
- 5 RECESSED DATE CODE
- 6 INDICATED PARTS ARE PACKAGED IN "SINGLE TUBES".
- 7 .000015 GOLD ON THE CONTACT AREA, .000100-.000200 MATTE TIN-LEAD ON THE SOLDERTAIL, ALL OVER .000050 NICKEL.
- 8 .000015 GOLD ON THE CONTACT AREA, .000100-.000200 MATTE TIN ON THE SOLDERTAIL, ALL OVER .000050 NICKEL.
- 9 PRELIMINARY PART
- 10 OBSOLETE PARTS: OBSOLETE CIS STREAMLINING PER D.RENAUD/D.SINISI

THIS DRAWING IS A CONTROLLED DOCUMENT.		DWN D.RINGLY 11JUN85	STE TE Connectivity Ltd.	
DIMENSIONS: INCHES		CHK D.DUPLER 11JUN85		
TOLERANCES UNLESS OTHERWISE SPECIFIED:		APVD -	NAME ASSEMBLY, MOD II,HEADER,SINGLE ROW .100 C/L, RIGHT ANGLE,WITH .025 SQ POST	
0 PLC ± -		PRODUCT SPEC -	APPLICATION SPEC -	
1 PLC ± -		WEIGHT -	SIZE A2	CAGE CODE 00779
2 PLC ± -		FINISH SEE TABLE	DRAWING NO C=102203	RESTRICTED TO -
3 PLC ± .005		CUSTOMER DRAWING	SCALE 4:1	SHEET 1 of 2
4 PLC ± -				REV W1
ANGLES ± -				
MATERIAL RETARDANT THERMOPLASTIC, COLOR-BLACK POSTS-PHOS BRONZE				

THIS DRAWING IS UNPUBLISHED. RELEASED FOR PUBLICATION
 © COPYRIGHT - By - ALL RIGHTS RESERVED.

REVISIONS				
P	LTR	DESCRIPTION	DATE	APVD
-	-	SEE SHEET 1	-	-

PLATING	D	C	B	A	NO OF POS	ASSEMBLY PART NUMBER
8	.820	.740	.600	6	7	8-102203-6 OBSOLETE
8	.420	.340	.200	2	3	8-102203-4
8	2.620	2.540	2.400	24	25	7-102203-2 OBSOLETE 10
8	2.520	2.440	2.300	23	24	7-102203-1 OBSOLETE 10
8	2.420	2.340	2.200	22	23	7-102203-0 OBSOLETE 10
8	2.320	2.240	2.100	21	22	6-102203-9
8	2.220	2.140	2.000	20	21	6-102203-8 OBSOLETE 10
8	2.120	2.040	1.900	19	20	6-102203-7
8	2.020	1.940	1.800	18	19	6-102203-6 OBSOLETE 10
8	1.920	1.840	1.700	17	18	6-102203-5
8	1.820	1.740	1.600	16	17	6-102203-4 OBSOLETE 10
8	1.720	1.640	1.500	15	16	6-102203-3
8	1.620	1.540	1.400	14	15	6-102203-2
8	1.520	1.440	1.300	13	14	6-102203-1
8	1.420	1.340	1.200	12	13	6-102203-0
8	1.320	1.240	1.100	11	12	5-102203-9
8	1.220	1.140	1.000	10	11	5-102203-8
8	1.120	1.040	.900	9	10	5-102203-7
8	1.020	.940	.800	8	9	5-102203-6 OBSOLETE 10
8	.920	.840	.700	7	8	5-102203-5
8	.820	.740	.600	6	7	5-102203-4
8	.720	.640	.500	5	6	5-102203-3
8	.620	.540	.400	4	5	5-102203-2
8	.520	.440	.300	3	4	5-102203-1

9	10	OBSOLETE	8	1.720	1.640	1.500	15	16	4-102203-0
SUPERSEDED BY 8-102203-4		8	.420	.340	.200	2	3	3-102203-9	
9	10	OBSOLETE	8	1.020	.940	.800	8	9	3-102203-8
SUPERSEDED BY 5-102203-1		8	.520	.440	.300	3	4	3-102203-7	
6	10	OBSOLETE	7	.820	.740	.600	6	7	3-102203-6
SUPERSEDED BY 103361-8		7	1.120	1.040	.900	9	10	3-102203-5	
7	7		.420	.340	.200	2	3	3-102203-4	
7	7	OBSOLETE	7	3.720	3.640	3.500	35	36	3-102203-3
7	7	OBSOLETE	7	3.620	3.540	3.400	34	35	3-102203-2
7	7	OBSOLETE	7	3.520	3.440	3.300	33	34	3-102203-1
7	7	OBSOLETE	7	3.420	3.340	3.200	32	33	3-102203-0
7	7	OBSOLETE	7	3.320	3.240	3.100	31	32	2-102203-9
7	7	OBSOLETE	7	3.220	3.140	3.000	30	31	2-102203-8
7	7	OBSOLETE	7	3.120	3.040	2.900	29	30	2-102203-7
7	7	OBSOLETE	7	3.020	2.940	2.800	28	29	2-102203-6
7	7	OBSOLETE	7	2.920	2.840	2.700	27	28	2-102203-5
7	7	OBSOLETE	7	2.820	2.740	2.600	26	27	2-102203-4
7	7	OBSOLETE	7	2.720	2.640	2.500	25	26	2-102203-3
10	7	OBSOLETE	7	2.620	2.540	2.400	24	25	2-102203-2
7	7		2.520	2.440	2.300	23	24	2-102203-1	
10	7	OBSOLETE	7	2.420	2.340	2.200	22	23	2-102203-0
7	7		2.320	2.240	2.100	21	22	1-102203-9	
10	7	OBSOLETE	7	2.220	2.140	2.000	20	21	1-102203-8
7	7		2.120	2.040	1.900	19	20	1-102203-7	
10	7	OBSOLETE	7	2.020	1.940	1.800	18	19	1-102203-6
10	7	OBSOLETE	7	1.920	1.840	1.700	17	18	1-102203-5
10	7	OBSOLETE	7	1.820	1.740	1.600	16	17	1-102203-4
7	7		1.720	1.640	1.500	15	16	1-102203-3	
7	7		1.620	1.540	1.400	14	15	1-102203-2	
7	7		1.520	1.440	1.300	13	14	1-102203-1	
7	7		1.420	1.340	1.200	12	13	1-102203-0	
7	7		1.320	1.240	1.100	11	12	102203-9	
7	7		1.220	1.140	1.000	10	11	102203-8	
7	7		1.120	1.040	.900	9	10	102203-7	
7	7		1.020	.940	.800	8	9	102203-6	
7	7		.920	.840	.700	7	8	102203-5	
7	7		.820	.740	.600	6	7	102203-4	
7	7		.720	.640	.500	5	6	102203-3	
7	7		.620	.540	.400	4	5	102203-2	
7	7		.520	.440	.300	3	4	102203-1	
FINISH	D	C	B	A	NO OF POS	ASSEMBLY PART NUMBER			

THIS DRAWING IS A CONTROLLED DOCUMENT.

DWN D.RINGLY 11JUN85	 TE Connectivity Ltd.
CHK D.DUPLER 11JUN85	
APVD -	NAME
PRODUCT SPEC -	ASSEMBLY, MOD II, HEADER, SINGLE ROW .100 C/L, RIGHT ANGLE, WITH .025 SQ POST
APPLICATION SPEC -	SIZE A2
MATERIAL -	CAGE CODE 00779
FINISH SEE TABLE	DRAWING NO 102203
CUSTOMER DRAWING	RESTRICTED TO -
SCALE 1:1	SHEET 2 of 2
REV W1	