

OPTION C

- NOTES:
- MATERIAL:
HOUSING: POLYESTER(PBT), GLASS FILLED, UL94 V-0,
COLOR: BLACK
TERMINAL: PHOSPHOR BRONZE
 - FINISH:
15 GOLD: 0.38 MICROMETERS/15 MICROINCHES MINIMUM GOLD IN
1.91 MICROMETERS/75 MICROINCHES MINIMUM TIN
OVER NICKEL UNDERPLATE OVERALL
 - TO BE USED WITH 26 AWG STRANDED WIRE WITH (1.35)/.053
DIAMETER MAXIMUM INSULATION
 - SEE TABLE FOR AVAILABLE CIRCUIT SIZES
 - STANDARD PACKAGING PER PK-70873-0001. OPTIONAL PACKAGING
MAY BE AVAILABLE, REQUEST DRAWING PK-70400
 - PARTS STACKABLE END TO END ON (2.54)/.100 CENTERS
 - PRODUCT SPECIFICATION: PS-70400
 - SEE DRAWING SDA-70400-**** (SHEET 3) FOR OPTIONAL
HOUSING DETAILS
 - 4 CIRCUIT SHOWN. 3-25 CIRCUITS HAVE 2 RIBS
 - TO MATE WITH MOLEX PART NUMBERS: A-70374-****,
A-70376-****, A-70390-****, A-70392-****,
A-70544-****, A-70554-****, A-70542-****,
A-70552-****, A-70546-****, A-70556-****,
 - 2 CIRCUIT ASSEMBLIES SUPPLIED AS GROUPED PAIRS

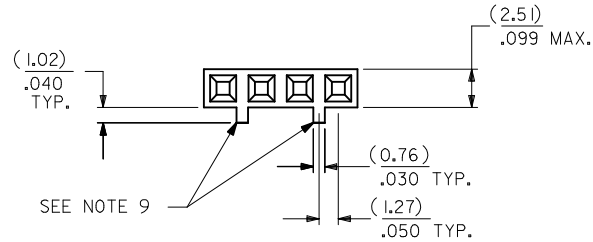

CIRCUIT NO. 1
SLOT OR ARROW

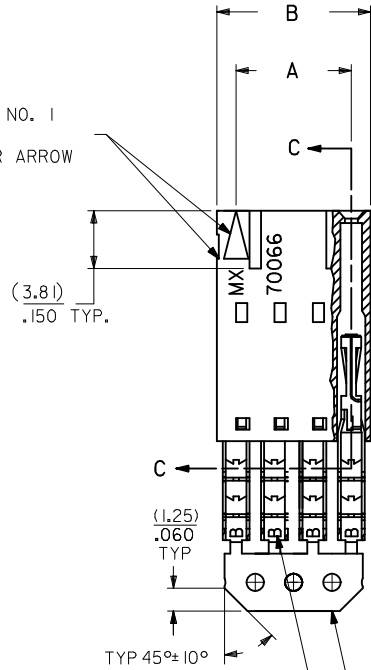

SECTION C-C

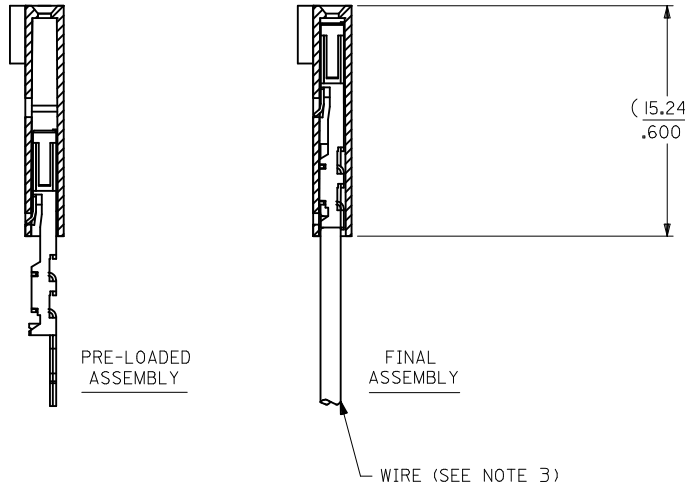

CKT. SIZE	A	B	EDP. NO.
2	(2.54) .100	(5.05) .199	14-56-3026
3	(5.08) .200	(7.59) .299	14-56-3036
4	(7.62) .300	(10.13) .399	14-56-3046
5	(10.16) .400	(12.67) .499	14-56-3056
6	(12.70) .500	(15.21) .599	14-56-3066
7	(15.24) .600	(17.75) .699	14-56-3076
8	(17.78) .700	(20.29) .799	14-56-3086
9	(20.32) .800	(22.83) .899	14-56-3096
10	(22.86) .900	(25.37) .999	14-56-3106
11	(25.54) 1.000	(27.91) 1.099	14-56-3116
12	(27.94) 1.100	(30.45) 1.199	14-56-3126
13	(30.48) 1.200	(32.99) 1.299	14-56-3136
14	(33.02) 1.300	(35.53) 1.399	14-56-3146
15	(35.56) 1.400	(38.07) 1.499	14-56-3156
16	(38.01) 1.500	(40.61) 1.599	14-56-3166
17	(40.64) 1.600	(43.15) 1.699	14-56-3176
18	(43.18) 1.700	(45.69) 1.799	14-56-3186
19	(45.72) 1.800	(48.23) 1.899	14-56-3196
20	(48.26) 1.900	(50.77) 1.999	14-56-3206
21	(50.80) 2.000	(53.31) 2.099	14-56-3216
22	(53.34) 2.100	(55.85) 2.199	14-56-3226
23	(55.88) 2.200	(58.39) 2.299	14-56-3236
24	(58.42) 2.300	(60.93) 2.399	14-56-3246
25	(60.96) 2.400	(63.47) 2.499	14-56-3256

I.D. SLOT CODE TO WIRE GAUGE CHART	
I.D. SLOT CODE	WIRE GAUGE
B	26 AWG.

PLATING CODE (STRIPE ON CARRIER STRIP)	
PLATING	COLOR
15 GOLD	YELLOW

REMOVE ENG NO. EC NO: UCP2011-110 DRW:MSI BARRA 2010/10/19 CHK:DJMORGAN 2010/10/19 APPR:SMILLER 2010/11/24	QUALITY SYMBOLS ▽=0 ▽=0 ▽=0	GENERAL TOLERANCES (UNLESS SPECIFIED) mm INCH 4 PLACES ± --- ± --- 3 PLACES ± --- ± .010 2 PLACES ± 0.25 ± .014 1 PLACE ± 0.35 ± --- ANGULAR ±1/2°	DIMENSION STYLE MM/IN DRAWN BY DATE MSI BARRA 2010/10/19 CHECKED BY DATE WAZ 1984/10/10 APPROVED BY DATE SMILLER 2010/11/24	SCALE DESIGN UNITS INCH TITLE ASSEMBLY, SL CONNECTOR SINGLE ROW 2.54/.100 GRID	THIRD ANGLE PROJECTION
		DRAFT WHERE APPLICABLE MUST REMAIN WITHIN DIMENSIONS	MATERIAL NO. SEE TABLE	DOCUMENT NO. SDA-70400-0736-0759	SHEET NO. 1 OF 1