

RECOMMENDED PCB LAYOUT

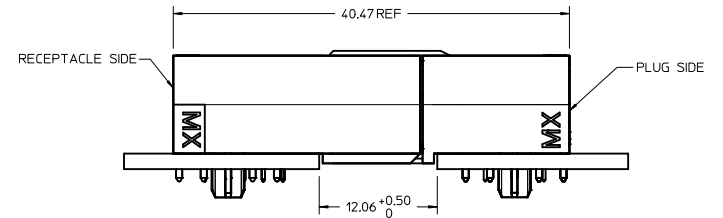

NOTES:

- MATERIAL:
  - HOUSINGS: LCP UL94, V-0, COLOR: BLACK.
  - TERMINALS: COPPER ALLOY.
  - PLATING: 0.00127 NICKEL OVERALL WITH 0.00254 SELECTIVE TIN ON SOLDER TAILS AND 0.000762 SELECTIVE GOLD ON CONTACT AREA.
- ASSEMBLIES PACKED IN TRAYS, SPO: TBD
- PC BOARD REQUIRES SOLDER THRU HOLES, REFER TO PS-46436-100 FOR DETAILS
- PRODUCT SPEC: PS-46436-100.
- APPLICATION SPEC: AS-46436-100.
- PRODUCT TO MEET ROHS REQUIREMENTS.
- ASSEMBLY MATES TO MOLEX RECEPTACLE ASSEMBLY P/N 46436-3102 OR 46562-3102

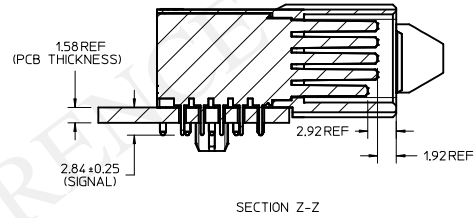
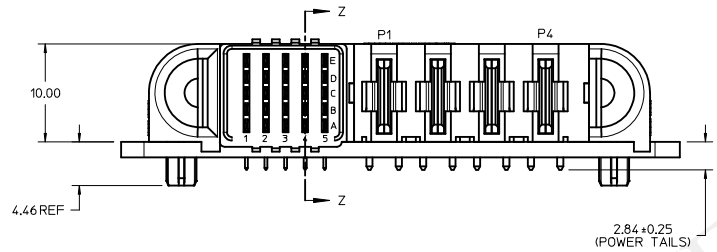
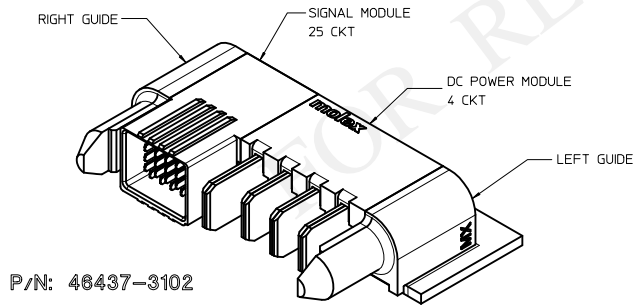

P/N: 46437-3102

|   |   |   |  |       |              |                            |
|---|---|---|--|-------|--------------|----------------------------|
| <b>PRIMARY RELEASE</b><br>IEC NO: UCP2011-1446<br>DRAWN: TMPATIL 2010/11/23<br>CHKD: J. SCHAFER<br>APPR: J. SCHAFER 2011/02/03<br>REV DESCRIPTION | QUALITY SYMBOLS   | GENERAL TOLERANCES (UNLESS SPECIFIED)   | DIMENSION STYLE  | SCALE | DESIGN UNITS | THIRD ANGLE PROJECTION     |
|   | $\nabla=0$<br>$\nabla=0$<br>$\nabla=0$  | mm INCH   | MM ONLY  | 4:1   | METRIC       |                            |
|   | 4 PLACES ± --- ± ---<br>3 PLACES ± --- ± ---<br>2 PLACES ± 0.13 ± ---<br>1 PLACE ± 0.25 ± ---<br>ANGULAR ± 1/2° | DRAWN BY DATE<br>TMPATIL 2010/11/23<br>CHECKED BY DATE<br>J. SCHAFER<br>APPROVED BY DATE<br>J. SCHAFER 2011/02/03 | TITLE  |       |              |                            |
|   | DRAFT WHERE APPLICABLE MUST REMAIN WITHIN DIMENSIONS  | MATERIAL NO.<br><b>46437-3102</b><br>DOCUMENT NO.<br><b>SD-46437-3102</b>   | <b>RA PLUG ASSY</b><br><b>25S-4P</b><br><b>TEN60 POWER FAMILY</b><br><b>MOLEX INCORPORATED</b> |       |              | SHEET NO.<br><b>1 OF 1</b> |

THIS DRAWING CONTAINS INFORMATION THAT IS PROPRIETARY TO MOLEX INCORPORATED AND SHOULD NOT BE USED WITHOUT WRITTEN PERMISSION