

MI DRG. NO.

6933-15A

REV.

**6933-15****A****TUNING ELEMENT**

## SPECIFICATIONS

FILE: AIROUT

LOW CONTACT RESISTANCE	< 0.01 OHMS
ROTATIONAL LIFE	> 1000 REVOLUTIONS
TUNING	0.3 TO 3.0 OZ. IN. (REF: 0.21 TO 2.12 Ncm)
	10 OZ. IN. MAX (REF: 7.06 Ncm)
MOUNTING	CLEARANCE HOLE $\phi$ .125 (.318) .123 (3.12)
	THREADED HOLE JMC TAP P/N 7060 (.120-80 UNS-2) TAP DRILL #36 (.1065)

## BRASS / INVAR STRUCTURE

## NOTES:

## 1. PLATING / FINISHES:

- BUSHING: JOHANSON STANDARD GOLD PLATING.
- ROTOR SCREW: JOHANSON CHROMATE CONVERSION, W/PRE-TORQUED AND LUBRICATED THREADS
- HEX NUT: JMC CHROMATE CONVERSION
- ROD: SILVER PLATED, 120  $\mu$ in (>3 $\mu$ m)

## 2. DIMENSIONS: INCHES

DIMENSIONS (mm), FOR REFERENCE

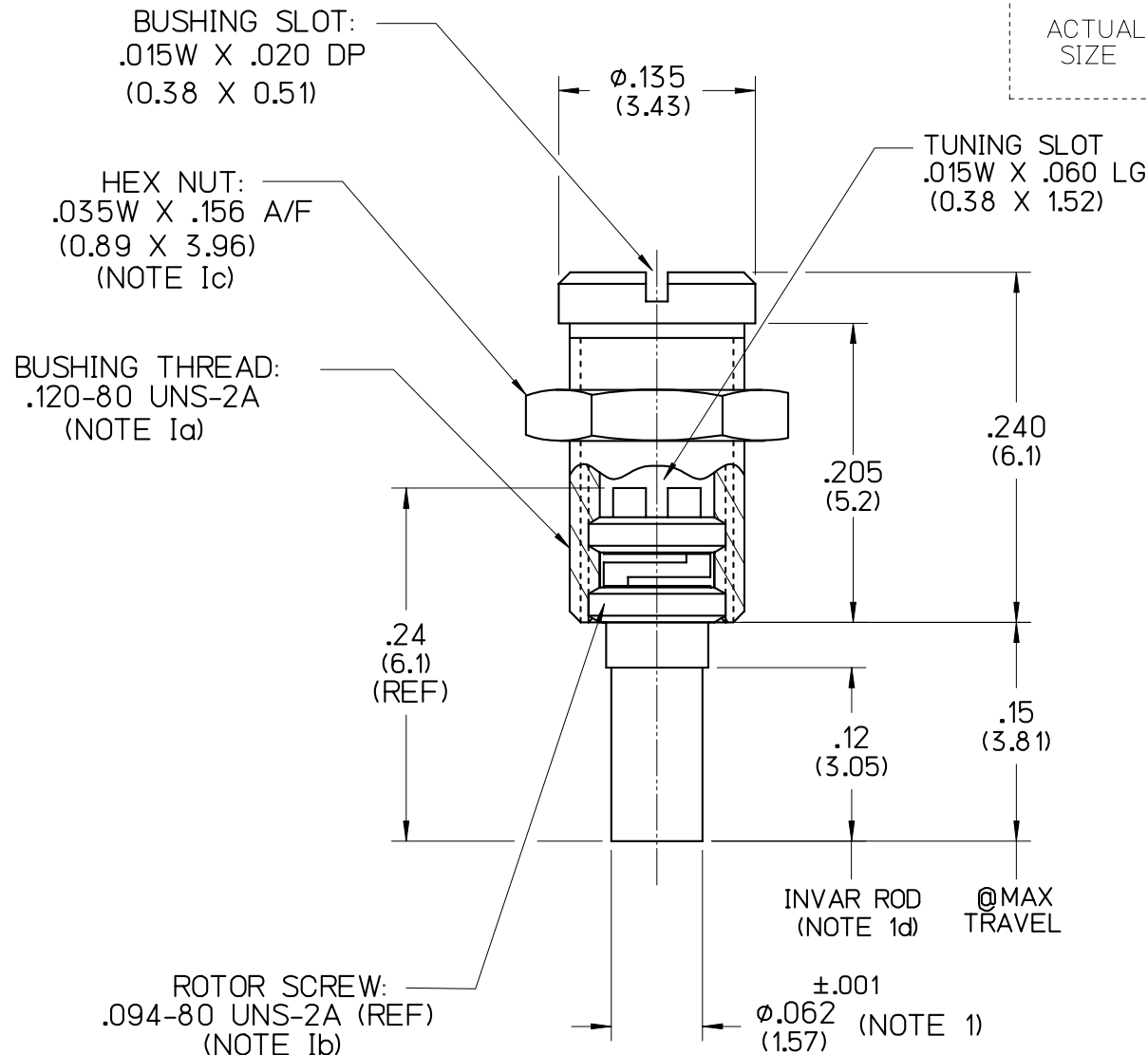

A	7/10/14	RJV	-	-	001253
LEVEL	DATE	DRN.	CHK.	APP.	ECN

## REVISIONS

DRN.	CHK.	APP.	SCALE
RJV	RJV	MAI	8" = 1"
DATE	DATE	DATE	.XX ± .015
7/10/14	7/10/14	7/10/14	.XXX ± .005

APPLICATIONS: FOR HIGH Q VARIABLE REACTANCE TUNING OF MICROWAVE CAVITIES, FILTERS, AND OTHER RESONANT STRUCTURES.

**JOHANSON MANUFACTURING CORPORATION**

ROCKAWAY VALLEY ROAD, BOONTON, N.J. 07005 (973)334-2676 FAX (973)334-2954  
ELECTRONIC ACCURACY THROUGH MECHANICAL PRECISION

PROPRIETARY INFORMATION CONTAINED NOT TO BE USED WITHOUT JOHANSON MANUFACTURING CORPORATION APPROVAL