

MMCX Straight Plug Receptacle

INCHES (MILLIMETERS)
CUSTOMER DRAWINGS AVAILABLE UPON REQUEST

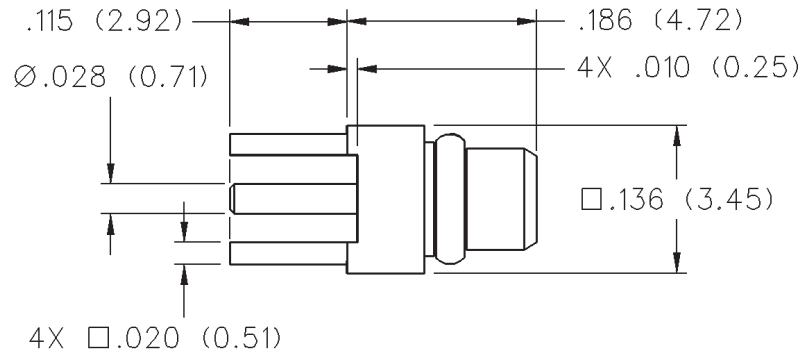

PART NUMBER
135-3801-201



Mounting Hole Layout

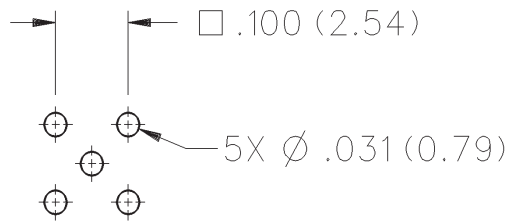

MMCX - 50 Ohm Connectors



Specifications

ELECTRICAL RATINGS

Impedance: 50 ohms

Frequency Range: Connectors 0-6 GHz
 Dummy loads 0-1 GHz

VSWR: (f = GHz)

	Straight Cabled Connectors	Right Angle Cabled Connectors
.047 dia flexible	1.20	1.14 + .07f
RG-178, RG-316, RG-316DS	1.20	1.25
.086 semi-rigid	1.15	1.15

Uncabled receptacles, dummy loads N/A

Working Voltage: Connectors 170 Vrms at sea level†
 Dummy loads N/A

Dielectric Withstanding Voltage: Connectors...500 Vrms at sea level†
 Dummy loads N/A

Insulation Resistance: 1000 megohms min

Contact Resistance: (milliohms maximum)

	Initial	After Environmental
--	---------	---------------------

Center contact (straight cabled connectors and uncabled receptacles)	5.0	8.0
--	-----	-----

Center contact (right angle cabled connectors)	5.0	15.0
--	-----	------

Outer contact (all connectors)	1.0	1.5
--------------------------------------	-----	-----

Braid to body	1.5	N/A
---------------------	-----	-----

Corona Level: Connectors 190 volts min at 70,000 feet†
 Dummy loads N/A

Insertion Loss: (dB max tested at 1 GHz)

Straight cabled connectors 0.1

Right angle cabled connectors 0.2

Uncabled receptacles, dummy loads N/A

RF Leakage: (dB minimum, tested at 2.5 GHz)

Flexible cable connectors -60 dB

.086 semi-rigid -70 dB

Dummy loads N/A

RF High Potential Withstanding Voltage: (400 Vrms at 4 and 7 MHz)†

Power Rating (Dummy Load): - 0.5 watt @ +25°C, derated to 0.25 watt @ +125°C

MECHANICAL RATINGS

Engagement Design: Series MMCX

Engagement/Disengagement Force: 8 lbs. max axial engagement
 1.4 lbs. min axial disengagement

Contact Retention: 2.0 lbs. minimum axial force

Cable Retention:	Axial Force* (pounds)	Torque (in-oz)
------------------	-----------------------	----------------

Connectors for .047 flexible	3.5	N/A
------------------------------	-----	-----

Connectors for RG-178	7.0	N/A
-----------------------	-----	-----

Connectors for RG-316	20.0	N/A
-----------------------	------	-----

Connectors for RG-316DS	25.0	N/A
-------------------------	------	-----

Connectors for .086 semi-rigid	30.0	16
--------------------------------	------	----

*Or cable breaking strength whichever is less.

Durability: 500 cycles minimum

ENVIRONMENTAL RATINGS (Meets or exceed the applicable paragraph of MIL-C-39012)

Operating Temperature: Connectors -65°C to +165°C
 Dummy loads -65°C to +125°C

Thermal Shock: Connectors: MIL-STD-202, Method 107, Condition C, except -55°C to +155°C (N/A dummy loads)

Corrosion: MIL-STD-202, Method 101, Condition B (N/A dummy loads)

Shock: MIL-STD-202, Method 213, Condition B (N/A dummy loads)

Vibration: MIL-STD-202, Method 204, Condition D (N/A dummy loads)

Moisture Resistance: MIL-STD-202, Method 106 (N/A dummy loads)

MATERIAL SPECIFICATIONS

Bodies: Brass per QQ-B-626, gold plated* per MIL-G-45204 .00001" min.

Contacts: Beryllium copper per QQ-C-530, gold plated* per MIL-G-45204 .00003" min.

Interface Spring: Beryllium copper per QQ-C-530, gold plated* per MIL-G-45204 .00003" min.

Insulators: PTFE fluorocarbon per ASTM D 1710 and ASTM D 1457

Crimp Sleeves: Copper per WW-T-799 or brass per QQ-B-626, gold plated per MIL-G-45204 .00001" min.

Mounting Hardware: Brass per QQ-B-626 or QQ-B-613, gold plated per MIL-G-45204 .00001" min.

†Avoid user injury due to misapplication.

See safety advisory definitions inside front cover.

*All gold plated parts include a .00005" min nickel barrier layer.

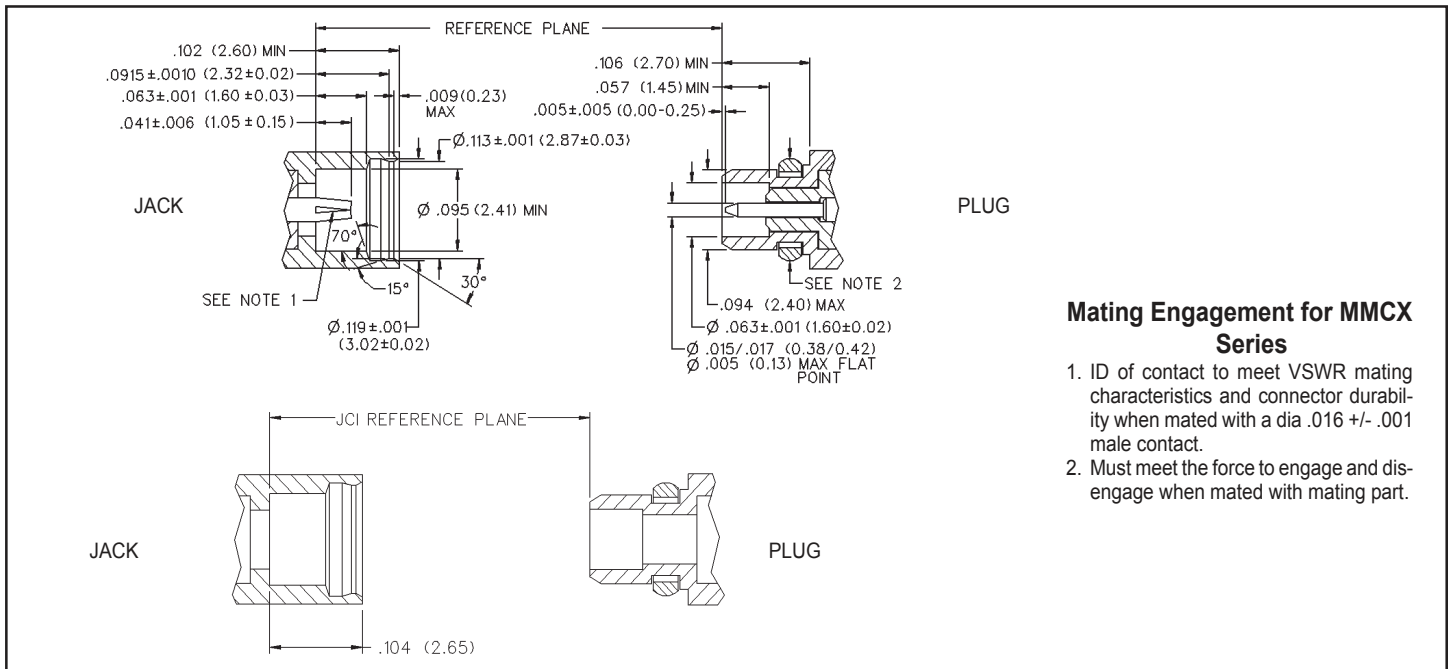

Mating Engagement for MMCX Series

1. ID of contact to meet VSWR mating characteristics and connector durability when mated with a dia .016 +/- .001 male contact.
2. Must meet the force to engage and disengage when mated with mating part.