

Spezifikation für Freigabe / specification for release

Kunde / customer :
 Artikelnummer / part number : **7498010210A**
 Bezeichnung : **LAN-Übertrager WE-RJ45LAN 10/100BaseT**
 description : **LAN-Transformer WE-RJ45LAN 10/100BaseT**



DATUM / DATE : 2014-12-17

A Mechanische Abmessungen / dimensions :

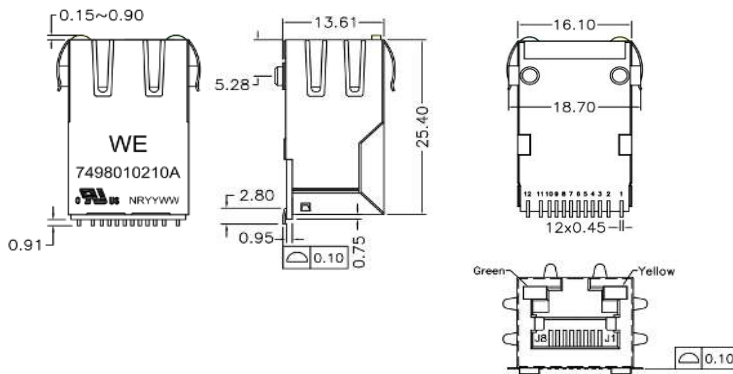

B Lötpad / soldering spec. :

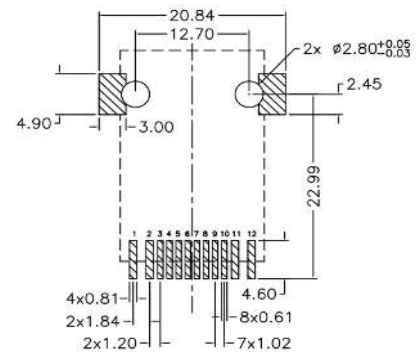

C Elektrische Eigenschaften / electrical properties :

| Eigenschaften / properties | Testbedingungen / test conditions | | Wert / value | Einheit / unit | tol. |
|--------------------------------------|-----------------------------------|-----|--------------|----------------|------|
| Induktivität / Inductance | 100kHz / 100mV @ 8mA DC-Bias | OCL | 350 | µH | min. |
| Übersetzungsverhältnis / Turns ratio | 100kHz / 100mV | TR | 1 : 1 | Tx | |
| | | | 1 : 1 | Rx | |
| Insertion Loss | 1-100MHz | IL | -1,0 | dB | max. |
| Return Loss | 1-10MHz @ 100Ω | RL | -20 | dB | min. |
| | 30MHz @ 100Ω | | -16 | | |
| | 60-80MHz @ 100Ω | | -12 | | |
| Common Mode Rejection | 1-50MHz | CMR | -30 | dB | min. |
| | 50-130MHz | | -20 | | |
| Crosstalk | 1-10MHz | CT | -40 | dB | min. |
| | 30-60MHz | | -35 | | |
| | 60-100MHz | | -30 | | |

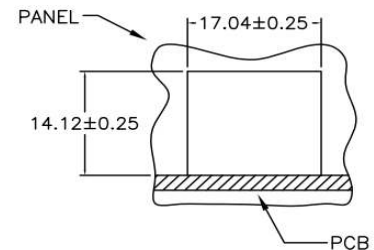

D Prüfgeräte / test equipment :

HP4395A

E Testbedingungen / test conditions :

Luftfeuchtigkeit / humidity: 33%
 Umgebungstemperatur / temperature: +25°C

F Werkstoffe & Zulassungen / material & approvals :

Basismaterial / base material: Ferrit/ ferrite
 Draht / wire: UEW 155°C
 Kontaktmaterial/ contact plating: 100% tin w. nickel underplating
 30µm gold plating on contact area
 Gehäuse / housing: Thermoplastic UL-94V0
 LED: 1,8-2,8 V/ 20mA
 Shield: 50µm nickel
 over 0.01" cooper alloy

G Eigenschaften / general specifications :

Betriebstemp. / operating temperature: -40°C - + 85°C
 Hochspannungsprüfung / Hipot test (all pins => contact fingers):
 2250VDC 1min.
 Geeignet für 10/100Base-TX gemäß IEEE 802.3u /
 Compliant with IEEE 802.3u for 10/100Base-TX-Applications
 Auto MDIX fähig / Auto MDIX capable

Freigabe erteilt / general release:

Kunde / customer

Datum / date

Unterschrift / signature

Würth Elektronik

Geprüft / checked

Kontrolliert / approved

| | | |
|------|-------------------------|--------------|
| Jliu | Rev 07 | 2014-12-17 |
| Mle | Rev 06 | 2014-01-07 |
| Mle | Rev 05 | 2012-07-18 |
| Mle | Rev 04 | 2012-06-21 |
| Mle | Rev 03 | 2011-10-21 |
| Mle | Rev 02 | 2011-09-19 |
| Mle | Rev 01 | 2012-07-18 |
| KSC | Rev 00 | 2010-06-10 |
| Name | Änderung / modification | Datum / date |

Würth Elektronik eiSos GmbH & Co.KG

D-74638 Waldenburg · Max-Eyth-Straße 1 - 3 · Germany · Telefon (+49) (0) 7942 - 945 - 0 · Telefax (+49) (0) 7942 - 945 - 400
<http://www.we-online.com>

Spezifikation für Freigabe / specification for release

Kunde / customer :
 Artikelnummer / part number : **7498010210A**
 Bezeichnung : **LAN-Übertrager WE-RJ45LAN 10/100BaseT**
 description : **LAN-Transformer WE-RJ45LAN 10/100BaseT**



DATUM / DATE : 2014-12-17

H Schaltbild / Schematics :

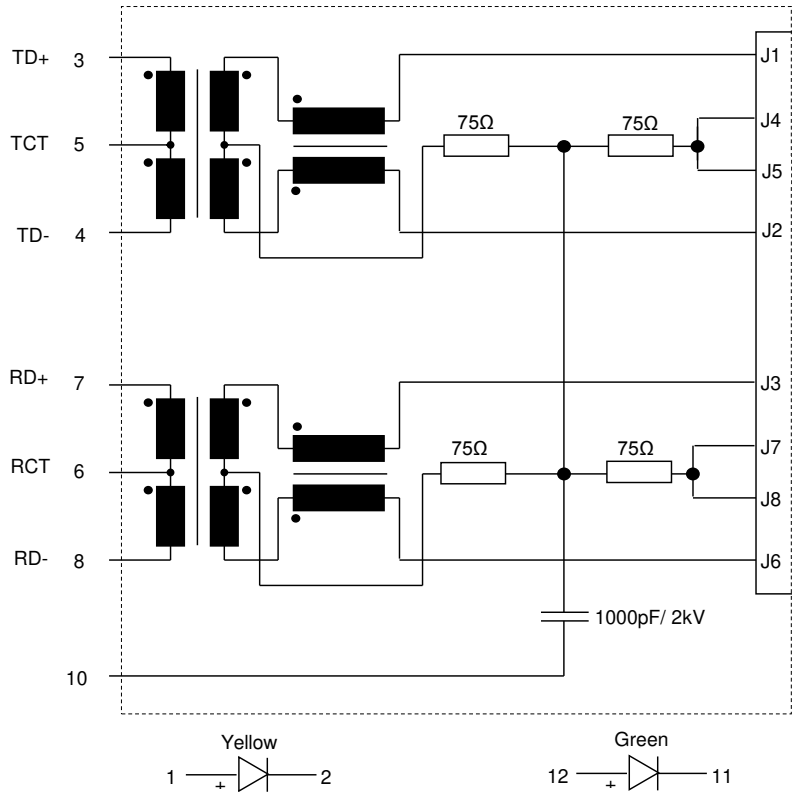

| | | | | |
|-------------------------------------|--------------------------|------|--------------------------------|--------------|
| Freigabe erteilt / general release: | Kunde / customer | | | |
| | | Jliu | Rev 07 | 2014-12-17 |
| | | Mle | Rev 06 | 2014-01-07 |
| | | Mle | Rev 05 | 2012-07-18 |
| | | Mle | Rev 04 | 2012-06-21 |
| Datum / date | Unterschrift / signature | Mle | Rev 03 | 2011-10-21 |
| | Würth Elektronik | Mle | Rev 02 | 2011-09-19 |
| | | Mle | Rev 01 | 2012-07-18 |
| | | KSC | Rev 00 | 2010-06-10 |
| Geprüft / checked | Kontrolliert / approved | Name | Änderung / modification | Datum / date |

Würth Elektronik eiSos GmbH & Co.KG

D-74638 Waldenburg · Max-Eyth-Straße 1 - 3 · Germany · Telefon (+49) (0) 7942 - 945 - 0 · Telefax (+49) (0) 7942 - 945 - 400
<http://www.we-online.com>

Spezifikation für Freigabe / specification for release

Kunde / customer :
 Artikelnummer / part number : **7498010210A**
 Bezeichnung : **LAN-Übertrager WE-RJ45LAN 10/100BaseT**
 description : **LAN-Transformer WE-RJ45LAN 10/100BaseT**



DATUM / DATE : 2014-12-17

I Verpackungsspezifikation / package specification :

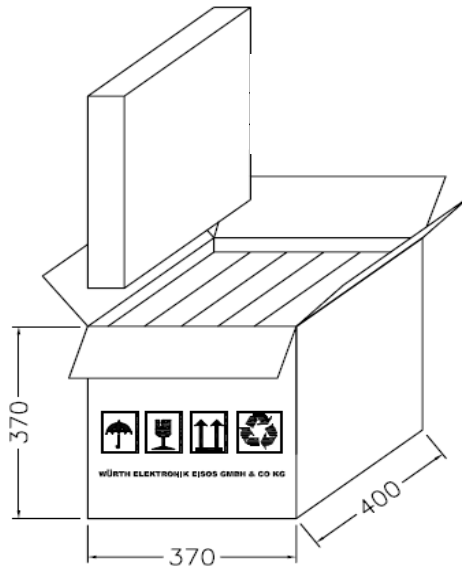
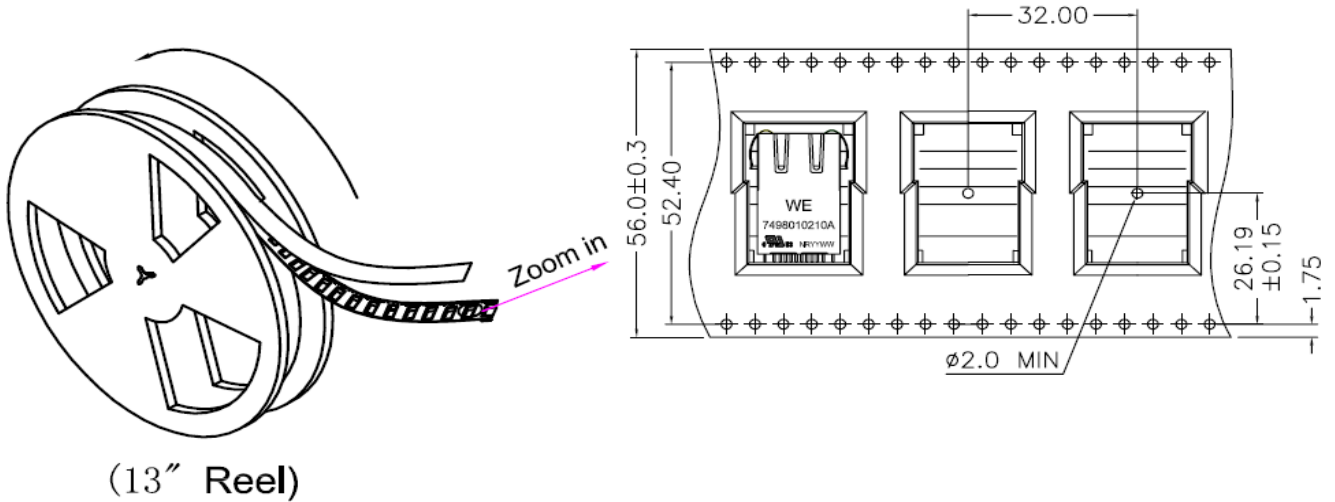

reel= 75pcs
 carton= 375pcs

dimensions in mm

| | | | | |
|-------------------------------------|--------------------------|------|-------------------------|--------------|
| Freigabe erteilt / general release: | Kunde / customer | Jliu | Rev 07 | 2014-12-17 |
| | | Mle | Rev 06 | 2014-01-07 |
| Datum / date | Unterschrift / signature | Mle | Rev 05 | 2012-07-18 |
| | | Mle | Rev 04 | 2012-06-21 |
| Geprüft / checked | Kontrolliert / approved | Mle | Rev 03 | 2011-10-21 |
| | | Mle | Rev 02 | 2011-09-19 |
| | Würth Elektronik | Mle | Rev 01 | 2012-07-18 |
| | | KSC | Rev 00 | 2010-06-10 |
| | | Name | Änderung / modification | Datum / date |

This electronic component has been designed and developed for usage in general electronic equipment. Before incorporating this component into any equipment where higher safety and reliability is especially required or if there is the possibility of direct damage or injury to human body, for example in the range of aerospace, aviation, nuclear control, submarine, transportation, (automotive control, train control, ship control), transportation signal, disaster prevention, medical, public information network etc, Würth Elektronik eiSos GmbH must be informed before the design-in stage. In addition, sufficient reliability evaluation checks for safety must be performed on every electronic component which is used in electrical circuits that require high safety and reliability functions or performance.

Würth Elektronik eiSos GmbH & Co.KG

D-74638 Waldenburg · Max-Eyth-Straße 1 - 3 · Germany · Telefon (+49) (0) 7942 - 945 - 0 · Telefax (+49) (0) 7942 - 945 - 400
<http://www.we-online.com>