

THIS DRAWING IS SUPPLIED FOR INFORMATION ONLY. DESIGN FEATURES, SPECIFICATIONS, AND PERFORMANCE DATA SHOWN HEREON ARE THE PROPERTY OF THE AMPHENOL CORPORATION. NO RIGHTS OF REPRODUCTION ARE IMPLIED. ALL DIMENSIONS ARE SUBJECT TO NORMAL MANUFACTURING VARIATIONS.

Customer Drawing

REVISIONS						
REV	ZONE	ECO	DESCRIPTION	DATE	BY	APPR
A	--	--	INITIAL RELEASE	03/13/14	RW	EC
D	--	ECNG180802	Add Metal Cover And Sealing Ring	08/21/18	Fred	JL
E	--	ECNG180802	Update Spec	08/29/18	Fred	JL
F	--	ECNG191025	更改图纸公差和注解	10/25/19	Steven	JL
G	--		Add Protection Cap	09/10/20	Steven	JL

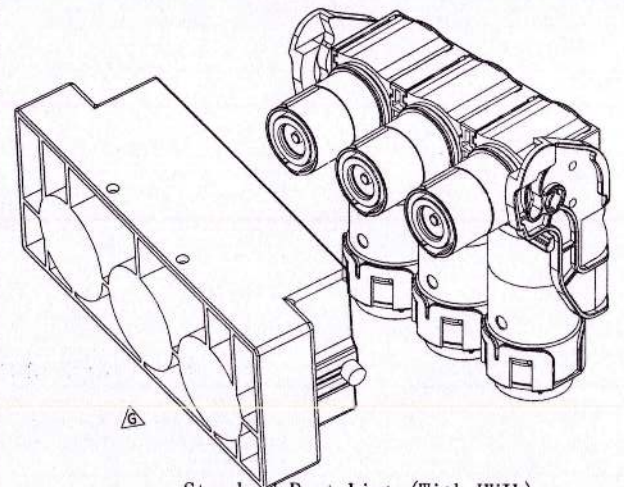
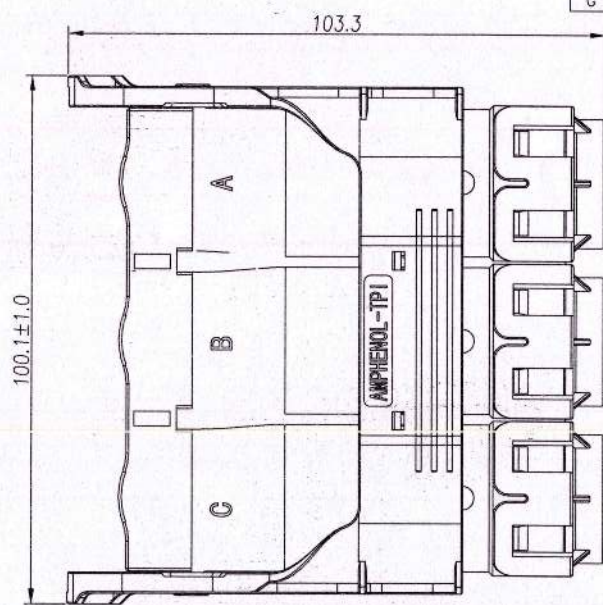
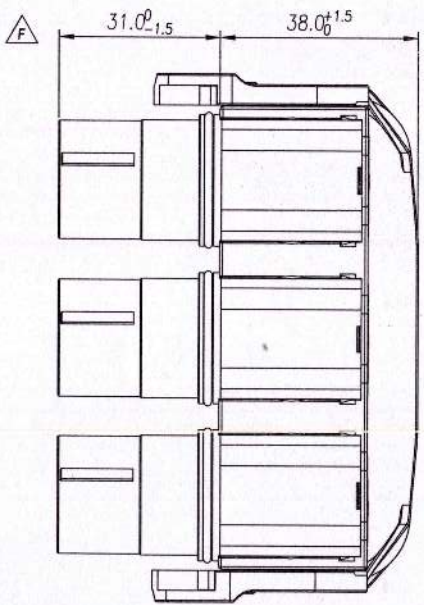

订购信息 Ordering Information

PL28 3 X - 30 1 - 70

键位及颜色 Key "X" Key "Y" Key	高压互锁 HVIL 0, 不带互锁 No HVIL 1, 带互锁 With HVIL	线缆大小 Cable Size "70"=70mm ² "50"=50mm ² "35"=35mm ²
---------------------------------	--	---

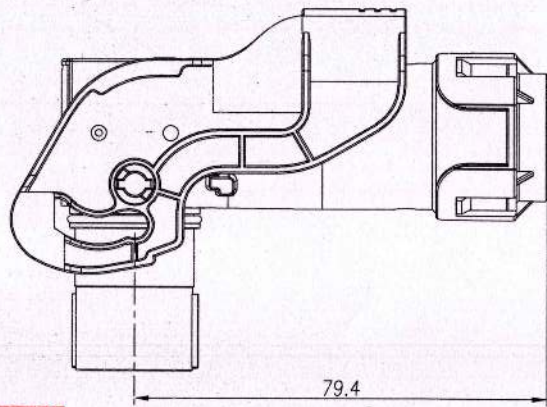

Standard Part List (With HVIL)

P/N	Model NO.	Polarization
AC-HA001120	PL283X-301-35	X
AC-HA001121	PL283Y-301-35	Y
AC-HA001122	PL283X-301-50	X
AC-HA001123	PL283Y-301-50	Y
AC-HA001124	PL283X-301-70	X
AC-HA001125	PL283Y-301-70	Y

Standard Part List (With Out HVIL)

P/N	Model NO.	Polarization
AC-HA001126	PL283X-300-35	X
AC-HA001127	PL283Y-300-35	Y
AC-HA001128	PL283X-300-50	X
AC-HA001129	PL283Y-300-50	Y
AC-HA001130	PL283X-300-70	X
AC-HA001131	PL283Y-300-70	Y

规格参数 (Spec.):

1. 工作温度 Operating temperature: -40° C~+125° C.
2. 额定电流 Current rating (Connector Only):
35mm²: 150A; 50mm²: 200A; 70mm²: 250A.
3. 额定电压 Operating voltage: 1000 VDC.
4. 耐电压 Dielectric withstanding voltage: 5000 VDC.
5. 防护等级 Protection class: IP67 & IP2X.
6. 电磁屏蔽 Shielding.
7. 机械寿命 Mating cycle: 100 Min.
8. 带自动二次锁扣 Automatic secondary lock.
9. 带高压互锁 Electrical interlock (HVIL).

Amphenol TPI
2020-09-28
REGISTERED COPY

AMPHENOL TPI	Amphenol Technical Products International Asia.			
	第三角投影 THIRD ANGLE PROJECTION	页码 SHEET	幅面 SIZE	版次 REV.
1 of 1	A3	G	比例 SCALE	
签名 SIGNATURE	日期 DATE	UNLESS OTHERWISE SPECIFIED		
制图 DRAWN Steven	09/10/20	1) All dimensions are in metric (mm).		
审核 CHECKED <i>[Signature]</i>	2020.9.10	2) Tolerances are as follows:		
批准 APPROVAL <i>[Signature]</i>	2020.9.10	0 PL DEC ±1.00 1 PL DEC ±0.50 2 PL DEC ±0.20		
		Angles ±1°		
PART NAME: PwrLok 10mm-90 3POS Plug Conn			DWG NO: PL283(-)-300	
CUST PART #: N/A			CUST REV. -	

THIS DRAWING IS SUPPLIED FOR INFORMATION ONLY. DESIGN FEATURES, SPECIFICATIONS AND PERFORMANCE DATA SHOWN HEREON ARE THE PROPERTY OF THE AMPHENOL CORPORATION. NO RIGHTS OF REPRODUCTION ARE IMPLIED. ALL DIMENSIONS ARE SUBJECT TO NORMAL MANUFACTURING VARIATIONS.

Customer Drawing

REVISIONS						
REV	ZONE	ECO	DESCRIPTION	DATE	BY	APPR
A	--	--	INITIAL RELEASE	03/13/14	RW	EC
D	--	ECNG180802	Add Metal Cover And Sealing Ring	08/21/18	Fred	JL
E	--	ECNG180802	Update Spec	08/29/18	Fred	JL
F	--	ECNG191025	更改图纸公差和注解	10/25/19	Steven	JL
G	--		Add Protection Cap	09/10/20	Steven	JL

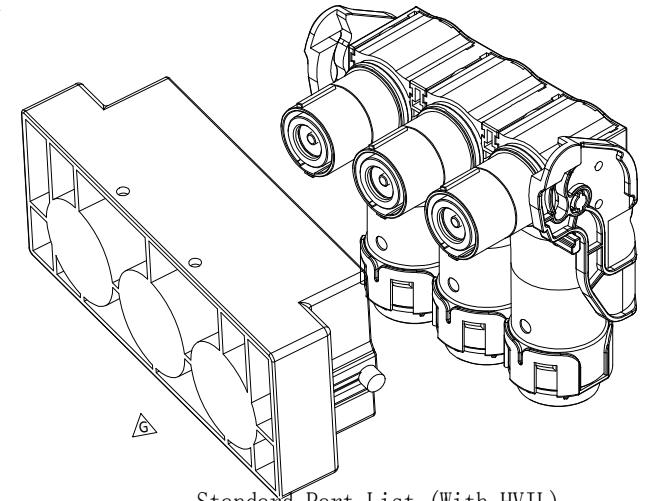
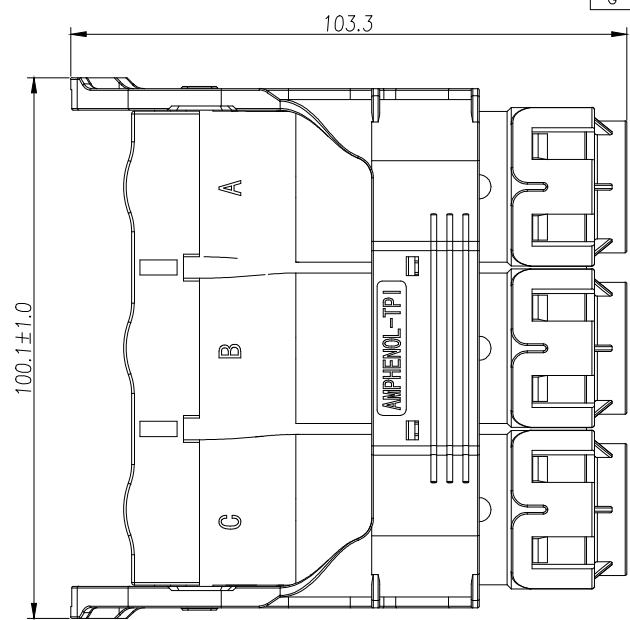
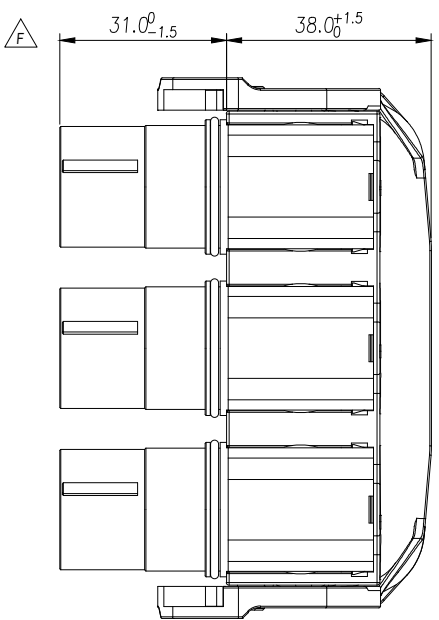

订购信息 Ordering Information

PL28 3 X - 30 1 - 70

键位及颜色 Key	高压互锁 HVIL	线缆大小 Cable Size
"X" Key	0, 不带互锁 No HVIL	"70"=70mm ²
"Y" Key	1, 带互锁 With HVIL	"50"=50mm ²
		"35"=35mm ²

Standard Part List (With HVIL)

P/N	Model NO.	Polarization
AC-HA001120	PL283X-301-35	X
AC-HA001121	PL283Y-301-35	Y
AC-HA001122	PL283X-301-50	X
AC-HA001123	PL283Y-301-50	Y
AC-HA001124	PL283X-301-70	X
AC-HA001125	PL283Y-301-70	Y

Standard Part List (With Out HVIL)

P/N	Model NO.	Polarization
AC-HA001126	PL283X-300-35	X
AC-HA001127	PL283Y-300-35	Y
AC-HA001128	PL283X-300-50	X
AC-HA001129	PL283Y-300-50	Y
AC-HA001130	PL283X-300-70	X
AC-HA001131	PL283Y-300-70	Y

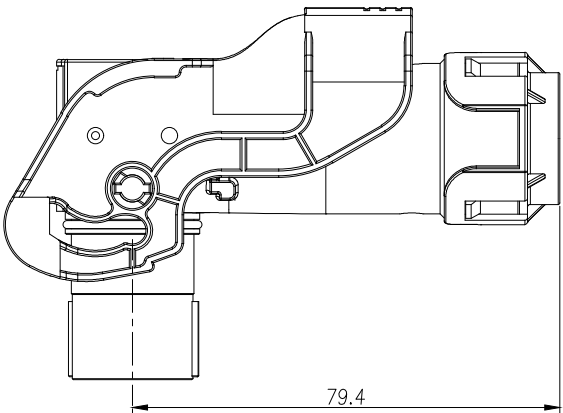

规格参数 (Spec.):

- 工作温度 Operating temperature: -40° C~+125° C.
- 额定电流 Current rating (Connector Only): 35mm²: 150A; 50mm²: 200A; 70mm²: 250A.
- 额定电压 Operating voltage: 1000 VDC.
- 耐电压 Dielectric withstanding voltage: 5000 VDC.
- 防护等级 Protection class: IP67 & IP2X.
- 电磁屏蔽 Shielding.
- 机械寿命 Mating cycle: 100 Min.
- 带自动二次锁扣 Automatic secondary lock.
- 带高压互锁 Electrical interlock (HVIL).

	Amphenol Technical Products International Asia.				
	第三角投影 THIRD ANGLE PROJECTION	页面 SHEET	幅面 SIZE	版次 REV.	比例 SCALE
签名 SIGNATURE	日期 DATE	UNLESS OTHERWISE SPECIFIED			DWG NO:
制图 DRAWN	Steven	1 OF 1	A3	G	PL283()-300
审核 CHECKED		1) All dimensions are in metric(mm). 2) Tolerances are as follows: 0 PL DEC ±1.00 1 PL DEC ±0.50 2 PL DEC ±0.20			CUST PART #:
批准 APPROVAL		Angles ±1°			N/A
					CUST REV. -