

NOTE This Instruction Sheet refers to the following AMP reference documentation:

AMP Stack Product Specification 108-22074
AMP Stack Application Specification 114-22007

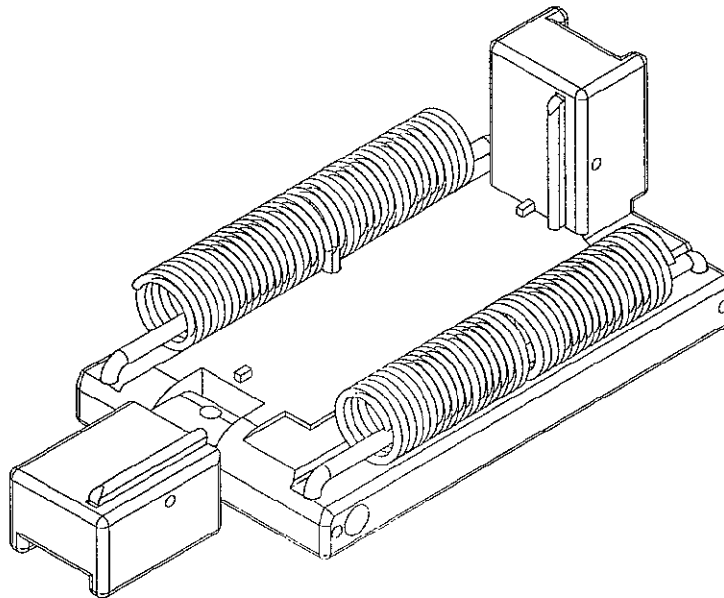

Fig 1

1. Introduction

The 10 Pair Piece-out Fixture (**Fig 1**) **1-525421-4** is designed as a substitute Splicing Head for a 10 Pair Splicing Kit **790112**, for use in situations where there is little or no slack cable available for jointing, also for Quad and Paper applications.

This procedure is usually referred to as 'Piecing-out' and should only be used to gain sufficient slack cable to enable the use of alternative jointing methods, as the ½ Tap Modules terminated will have cut wire ends exposed and must be removed subsequently (*refer to your company's jointing procedures*).

2. Description

The fixture is made from steel and has one drop down end plate so as to make insertion into tight cable as easy as possible. A ball detent arrangement holds the plate in either the horizontal position (**Fig 1**) or the vertical position

(**Fig 3**) for termination.

Two spring loaded locators provide location for the AMP Stack modules, whilst orientation is helped with visual aids.

Two rows of nylon coated springs grip individual wires providing secure insulated location during jointing.

3. Applications

It is possible to terminate / apply the following Module combinations in this fixture using the 10 Pair Splicing Kit Hand Tool:

1. ½ Tap or Straight
2. Pluggable
3. ½ Tap or Straight + Pluggable
4. Pluggable + Pluggable

Max wire conductor size Ø 0.9 mm

Max wire insulation size Ø 1.95 mm

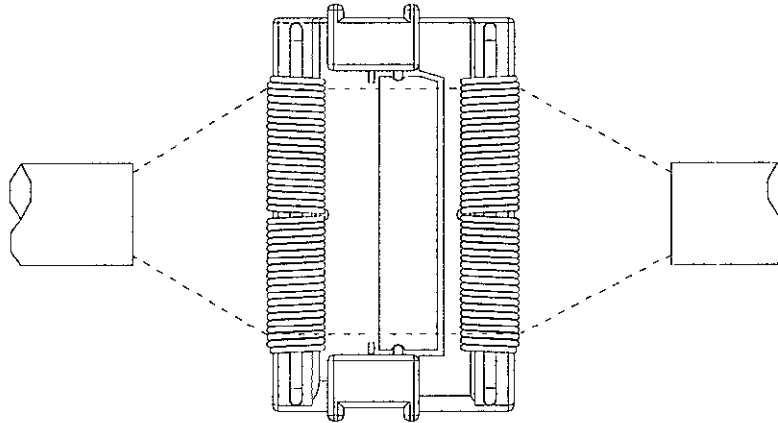
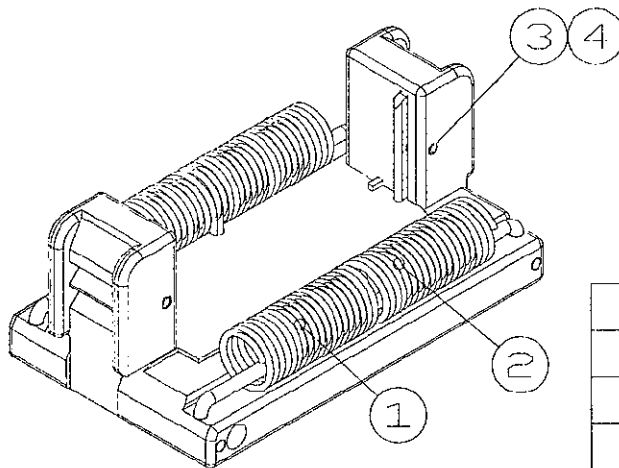

Fig 2

Operation

1. Load a 10 pair Module Base into the Piece-out Fixture taking care to align the angled end correctly with the visual aid on the fixture base (*Fig 2*), position the hinged end plate in the horizontal position and manoeuvre the fixture into the cable.
2. Align the correct pairs of wires (*refer to Product Specification 108-22074*) securing them in the location springs provided.
3. Load the ½ Tap Module (*refer to Product Specification 108-22074*).
4. Repeat step 2.
5. Fit the Module Lid (*refer to Product Specification 108-22074*).
6. Terminate the Module (*refer to Application Specification 114-22007*)



4	SPRING PIN	993111-8
3	COMPRESSION SPRING	3-23147-4
2	PVC SPRING	790117-4
1	PVC SPRING	790117-3
ITEM	DESCRIPTION	PART N°

Fig 3

Should any damage occur to the items listed above (*Fig 3*), contact AMP's technical sales department at the address below to order replacement parts.