

AE-ISP-U2

DIP28/BH10 universal adapter for in system programming.

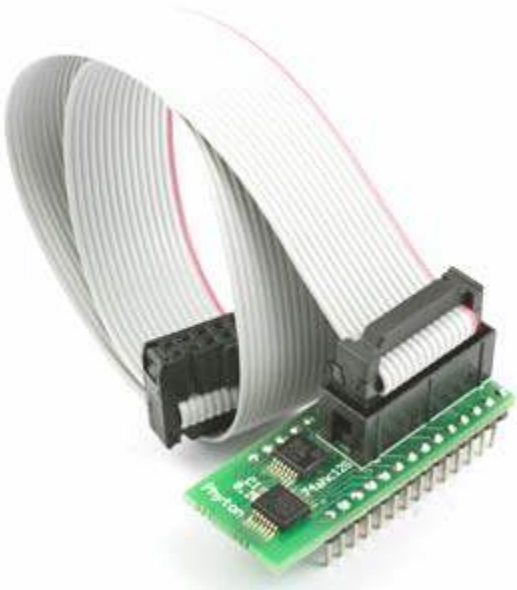

Click the programmer model below to get an appropriate list of the devices supported by the adapter:

- [ChipProg-40](#)
- [ChipProg-48, ChipProg-G4](#)

Adapter Connection Table:

DIP-28	BH10	74AC125	74AC125	C1, 0.1uF
1	1	3		
2	3	6		
3	5	8		
4	7			
5	9		3	
6		2		
7		1		
8		5		
9		14	14	2
10		9		
11		10		
12		12		
13		13		
14		7	7	1
15		4		
16			5	
17			4	
18			9	
19			10	
20			12	

21			13	
22			2	
23			1	
24	10		6	
25	8			
26	6		8	
27	4		11	
28	2	11		

[AE-ISP-U2 connection for Altera EPM3000](#)

[AE-ISP-U2 connection for LPC Flash and Firmware Hub](#)

AE-ISP-U2 connection for Altera EPM3000

Click the programmer model below to get an appropriate list of the devices supported by the adapter:

- [ChipProg-48, ChipProg-G4](#)

Recommended connection:

ISP Connector

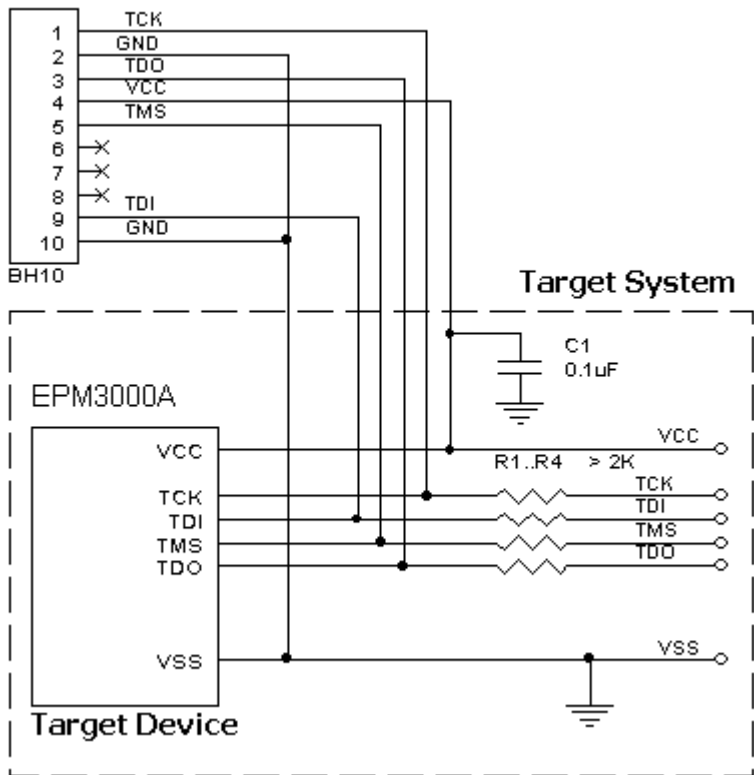

There are two alternative options for powering the targets:

1. The target gets power from the programmer (Vdd). This is possible only if the target does not consume too much energy. A capacity of the target power circuitry should not exceed 50 uF.
2. The target gets power from a built-in or external power supply. In this case the power output from the programmer should not be connected with the target. The target system should be tolerant to applying logical signals with the voltage levels exceeding the voltages on the target.

NOTE! It is strictly prohibited to power the target from both the programmer and built-in or external power supply simultaneously.

Purpose of the R1..R4 resistors is to isolate the programmed chip from rest of target system. Recommended value of resistors R1..R4 is 2k or more. You can also use jumpers instead of the resistors.

Table of connections of the adapter output socket to the device pins:

Adapter Output connector, BH-10	Target Device EPM3xxx
1	TCK
2	GND
3	TDO
4	VCC
5	TMS

6,7,8	-
9	TDI
10	GND

AE-ISP-U2 connection for LPC Flash and Firmware Hub

Click the programmer model below to get an appropriate list of the devices supported by the adapter:

- [ChipProg-40](#)
- [ChipProg-48, ChipProg-G4](#)

Recommended connection:

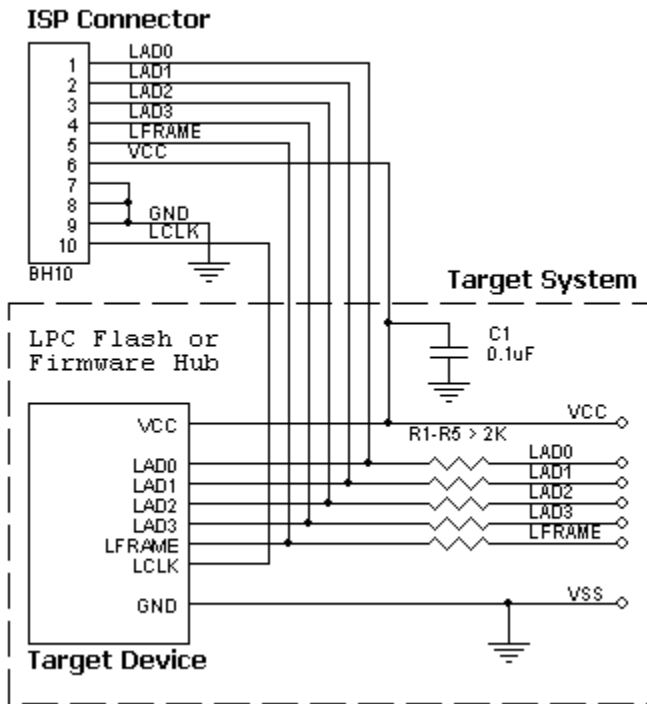

There are two alternative options for powering the targets:

1. The target gets power from the programmer (Vdd). This is possible only if the target does not consume too much energy. A capacity of the target power circuitry should not exceed 50 uF.
2. The target gets power from a built-in or external power supply. In this case the power output from the programmer should not be connected with the target. The target system should be tolerant to applying logical signals with the voltage levels exceeding the voltages on the target.

NOTE! It is strictly prohibited to power the target from both the programmer and built-in or external power supply simultaneously.

Purpose of the R1..R5 resistors is to isolate the programmed chip from rest of target system. Recommended value of resistors R1..R5 is 2k or more. You can also use jumpers instead of the resistors.

Table of connections of the adapter output socket to the device pins:

Adapter Output connector, BH-10	Target Device LPC Flash or Firmware Hub
1	LAD0
2	LAD1
3	LAD2
4	LAD3
5	LFRAME
6	VCC
7,8,9	GND
10	LCLK