

Toggles

Rockers

Pushbuttons

Illuminated PB

Programmable **E**

Keylocks

Rotaries

Slides

Tactiles

Tilt

Touch

Indicators

Accessories

Supplement

DISTINCTIVE CHARACTERISTICS

Compact Size Combined with High Resolution

- High resolution of 64 x 32 pixels
- 64 colors of backlighting can be controlled dynamically
- Pushbutton switch with LCD, RGB LED backlighting
- General brightness of backlight is dynamically controlled in eight steps from dark to bright
- Operated by commands and data supplied via serial communications (SPI)
- Can display as many as four lines of text with ten characters each
- Incorporates bitmap display function
- Programmable display graphics for alphanumeric characters and animated sequences
- Dual image VRAM for quick change of displayed images
- Low energy consumption
- Dust tight construction

Viewing area: 14.5mm x 11.8mm (horizontal x vertical)

Variety of LED backlighting with 64 colors and 8 steps brightness

Dome gives crisp tactile feedback to positively indicate circuit transfer

Epoxy sealed straight PC terminals

Snap-in standoff for easy, secure mounting and alignment



Actual Size

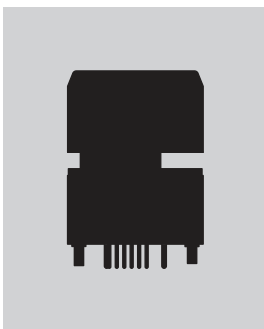

PART NUMBER & DESCRIPTION

Part Number	Switch Description	LCD Mode	LED Color
IS15ESBFP4RGB	SPST Momentary ON Gold Contacts Straight PC Terminals	Black & White FSTN Positive	Red/Green/Blue

SWITCH SPECIFICATIONS

Circuit	SPST normally open
Electrical Capacity (Resistive Load)	100mA @ 12V DC
Contact Resistance	200 milliohms maximum @ 20mV 10mA
Insulation Resistance	100 megohms minimum @ 100V DC
Dielectric Strength	125V AC for 1 minute minimum
Mechanical Endurance	1,000,000 operations minimum
Electrical Endurance	1,000,000 operations minimum
Operating Force	1.7 ± 0.5 Newtons
Total Travel	1.8mm (.071")

Absolute Maximum Ratings (Temperature at 25°C)

Items	Symbols	Ratings
Supply Voltage	V _{DD}	-0.3V to +7.0V
Input Voltage	V _I	-0.3V to V _{DD} +0.3V
Output Voltage	V _O	-0.3V to V _{DD} +0.3V

Optical Characteristics (Temperature at 25°C)

Items	Symbols	Minimum	Typical	Maximum
Contrast Ratio	Cr	—	3.0	—
Viewing Angle (Cr ≥ 1.1)	Up & Down	θ	90°	—
	Right & Left	φ	90°	—

LCD SPECIFICATIONS

Characteristics of Display

Display Operation Mode	FSTN positive; background colors, black & white
Display Condition	Transflective with built-in LED backlight
Viewing Angle Direction	6 o'clock
Viewing Area	14.5mm x 11.8mm (horizontal x vertical)
Pixel Format	64 x 32 pixels (horizontal x vertical)
Pixel Size	0.200mm x 0.285mm (horizontal x vertical)
* Operating Temp Range	-15°C ~ +50°C (+5°F ~ +122°F)
Storage Temp Range	-20°C ~ +60°C (-4°F ~ +140°F)
Backlight LED	RGB: red/green/blue

* In a low temperature environment (below 0°C), speed and contrast decrease when image changes. The non-indicator dot may become dense in a high temperature environment (about +50°C). Highest backlight brightness level should not be used for temperatures above +35°C.

Recommended Operating Conditions (Temperature at 25°C)

Items	Symbols	Minimum	Typical	Maximum
Supply Voltage	V _{DD}	4.9V	5.0V	5.1V
High Level Input Voltage	V _{IH}	0.8 V _{DD}	—	—
Low Level Input Voltage	V _{IL}	—	—	0.2V _{DD}
SPI Clock Frequency	f _{SCK}	—	—	8MHz
Current Consumption	I _{DD}	** 10mA	—	*** 60mA

** 10mA: Backlighting LED is off

*** 60mA: Backlighting LEDs (Red, Green, Blue) are maximum brightness

BLOCK DIAGRAM & PIN CONFIGURATIONS



IS15ESBFP4RGB
RGB LED Backlight
Black and White LCD

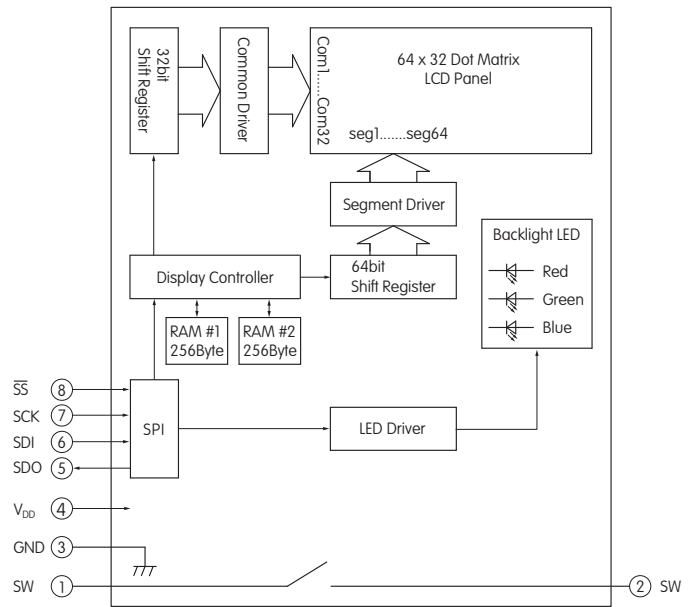

Pin No.	Symbol	Name	Function
①	SW	Terminal of Switch	Normally open
②	SW	Terminal of Switch	Normally open
③	GND	Ground	
④	V _{DD}	Power	Power source for logic circuit and LCD
⑤	SDO	Data Out	Data output line for SPI
⑥	SDI	Data In	Data input line for SPI
⑦	SCK	Serial Clock	Clock line for SPI that synchronizes commands and data
⑧	SS	Slave Select	Chip select for SPI; line is active low

TYPICAL SWITCH DIMENSIONS

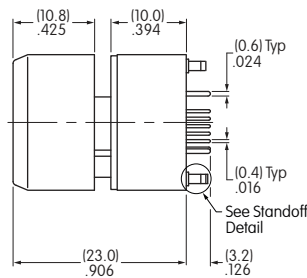
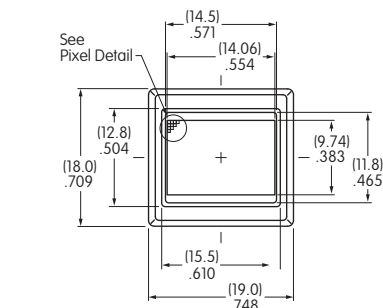

Terminal numbers are not on the switch.

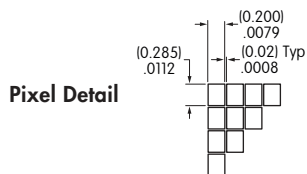
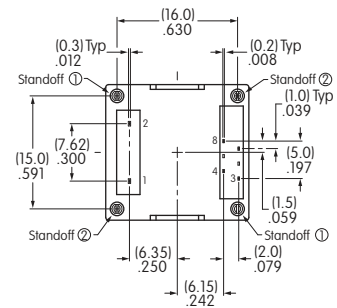

Standoff Detail

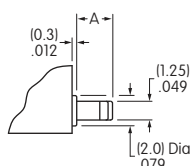

Footprint

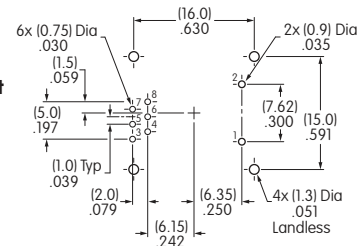

Dimension A

Standoff 1 = (2.7) .106 Standoff 2 = (2.3) .091

The Compact LCD 64 x 32 Pushbutton may utilize the same footprint as the Standard Travel LCD 64 x 32 Pushbutton.

TIMING SPECIFICATIONS FOR SWITCHES & DISPLAY

SPI Characteristics (See Timing Diagram)

(Temperature at -15°C ~ +50°C and $V_{DD} = 5.0V \pm 2\%$)

Items	Symbols	Minimum	Maximum
SPI \overline{SS} Set Up Time	t_{sSS}	10ns	
SPI \overline{SS} Hold Time	t_{hSS}	10ns	
SPI_CLK Cycle	t_{cycCK}		8MHz
SPI_CLK Width	t_{hwCK}	10ns	
SPI_DI Set Up Time	t_{sDI}	10ns	
SPI_DI Hold Time	t_{hDI}	10ns	
SPI_DO Delay Time	t_{dDO}	10ns	

SPI Timing Chart (\overline{SS} Using)

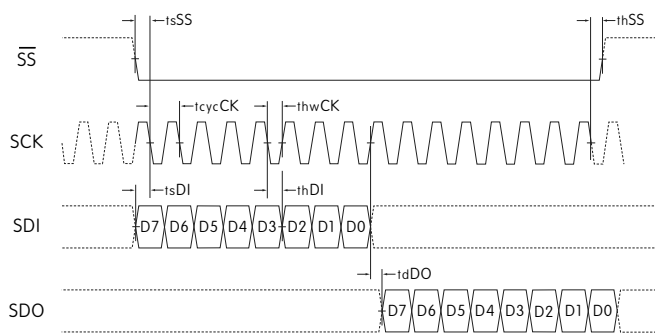

Circuit Example

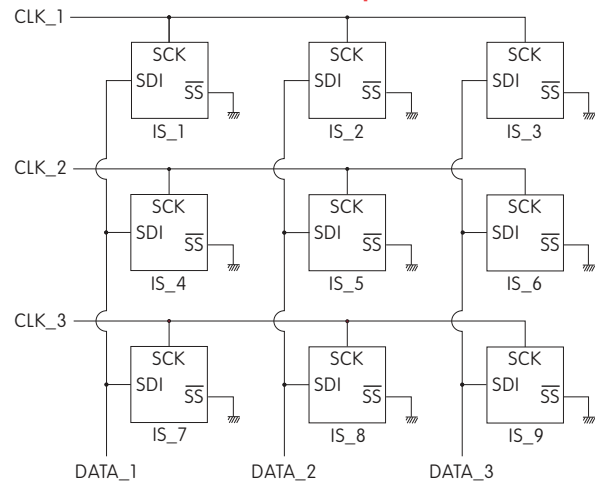

It is recommended that all \overline{SS} pins be connected to a controller pin instead of ground. A clock glitch during power up could cause the communication to fall out of sync. Toggling the \overline{SS} line resets the communication.

SPI Timing Chart (\overline{SS} Low Level Fixed)

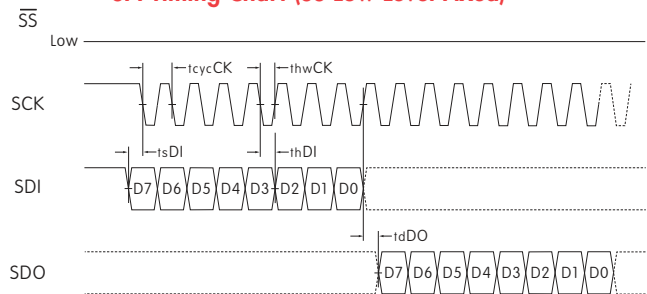

SDI and SCK shall be kept high when idle.

BITMAP

Segment

Common	1	2	3	4	5	6	7	8	9	•••	16	•••••	49	•••	56	57	58	59	60	61	62	63	64									
	Byte8								Byte7				Byte2				Byte1															
COM1	D0	D1	D2	D3	D4	D5	D6	D7	D0	•••	D7	•••	D0	•••	D7	D0	D1	D2	D3	D4	D5	D6	D7									
	Byte16																Byte9															
COM2	D0	D1	D2	D3	D4	D5	D6	D7																	D0	D1	D2	D3	D4	D5	D6	D7
•																																
•																																
•																																
	Byte256								•••				•••				Byte249															
COM32	D0	D1	D2	D3	D4	D5	D6	D7																	D0	D1	D2	D3	D4	D5	D6	D7

Transferring Display Data/Displaying LCD Command and Data Sequence

Command	Data (256 Bytes)																															
0 x 55	Byte1								Byte2 ••• Byte255																Byte256							
0 1 0 1 0 1 0 1	D7	D6	D5	D4	D3	D2	D1	D0	D7	D6	•••	D1	D0	D7	D6	D5	D4	D3	D2	D1	D0											

Notes: Display RAM has two screen areas. The first area is for the display on current LCD; the second area is for the data to be displayed next. The screens are changed when the second area is fully stored. Set an interval of 16msec or more from the end of the previous data reception to the start of the next command reception.

Toggles
 Rockers
 Pushbuttons
 Illuminated PB
E Programmable
 Keylocks
 Rotaries
 Slides
 Tactiles
 Tilt
 Touch
 Indicators
 Accessories
 Supplement

COMMANDS & DATA

- Transferring display data/displaying on LCD: command (1 Byte) + data (256 Bytes)
- Others: command (1 Byte) + data (1 Byte)
- Commands can be accepted only when all bits coincide; otherwise, they are not acknowledged
- Additional commands will not be received until the communication of commands (1 Byte) and data (256 or 1 Byte) is completed
- There is no time limit from the beginning to end of data receipt
- Commands may be executed consecutively (no need to wait between commands), except for display data
- For display data, set an interval of 16msec or more from the end of previous data reception to the start of the next command reception
- Irregular commands or data are not recognized
- Initial status at power activation: LCD display off, LED off (brightness 1/20, color off)

Transferring Display Data/Displaying on LCD

Command		Data	Remarks
Hex	Binary		
0 x 55	01010101	256 Bytes (64 x 32 = 2,048 bits)	See above for details of bitmap data

LED (Backlight) Color Set

Command		Data	Remarks
Hex	Binary		
0 x 40	01000000	R R G G B B 1 1 2 bits x 3	For each of RGB: 00 = off 10 = 1/2 01 = 1/4 11 = full

LED (Backlight) Brightness Set

Command		Data	Remarks
Hex	Binary		
0 x 41	01000001	* * * 1 1 1 1 1 3 bits	For leading 3bits: 000 = 1/20 (dark) 100 = 1/3 001 = 1/10 101 = 1/2 010 = 1/7 110 = 2/3 011 = 1/5 111 = full (bright)

Reset (Returning to Initial Status at Power Activation)

Command		Data	Remarks
Hex	Binary		
0 x 5E	01011110	0000011	Returning to initial status at power activation

PRECAUTIONS FOR HANDLING & STORAGE OF LCD 64 x 32 DEVICES

Handling

1. The IS Series devices are electrostatic sensitive.
2. Limit operating force to keytop to 100.0N maximum, as excessive pressure may damage the LCD device.
3. The IS series devices are not process sealed.
4. If the LCD is accidentally broken, avoid contact with the liquid and wash off any liquid spills to the skin or clothing.
5. Clean cap surface with dry cloth. If further cleaning is needed, wipe with dampened cloth using neutral cleanser and dry with clean cloth. Do not use organic solvent.
6. Recommended soldering time and temperature limits:
Do not exceed 60°C at the LCD level.
Wave Soldering: see Profile B in Supplement section.
Manual Soldering for Switch: see Profile A in Supplement section.
Manual Soldering for Display: see Profile B in Supplement section.
7. Excessive images may result after the same image is emitted continuously for an extended period of time.
8. The highest backlight brightness level should not be used for temperatures above +35°C.

Storage

1. Store in original container and away from direct sunlight.
2. Keep away from static electricity.
3. Avoid extreme temperatures, high humidity, gaseous substances, and all forms of chemical contamination.



OPTIONAL ACCESSORIES

AT9704-02YC Socket for Single and Bicolor LCD 36 x 24 Pushbutton

Materials:

Base - Glass Fiber Reinforced PBT
 Terminals - Brass/Beryllium Copper

- The socket permits the SmartDisplay to be plugged in after automated processing.
- Use of the socket enables easy field replacement of the device.

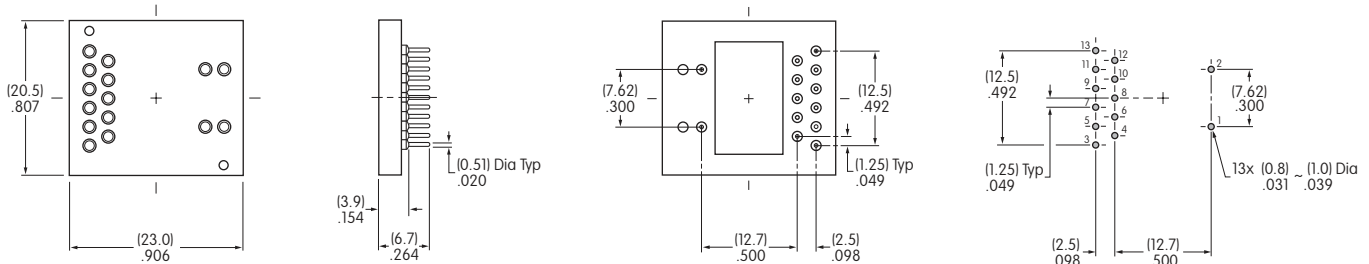

Compatible Part Number for AT9704-02YC

LCD 36 x 24

IS15BAFP4CF

AT9704-065E Socket for RGB LCD 36 x 24 Pushbutton

Materials:

Base - Glass Fiber Reinforced PBT
 Terminals - Brass/Beryllium Copper

- The socket permits the RGB SmartDisplay to be plugged in after automated processing.
- Use of the socket enables easy field replacement of the device.

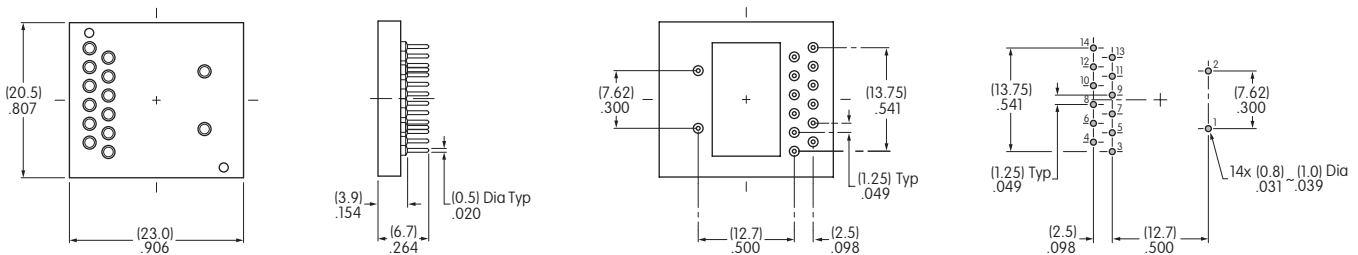

Compatible Part Numbers for AT9704-065E

RGB LCD 36 x 24

IS15BBFP4RGB

Bicolor LCD 36 x 24

* IS15BAFP4CF

* AT9704-065E Socket may be used with IS15BAFP4CF by removing pin 3.

AT9704-065F Socket for Compact Pushbutton (All Models)

Materials:

Base - Glass Fiber Reinforced PBT
 Terminals - Brass/Beryllium Copper

- The socket permits the Compact SmartDisplay to be plugged in after automated processing.
- Use of the socket enables easy field replacement of the device.

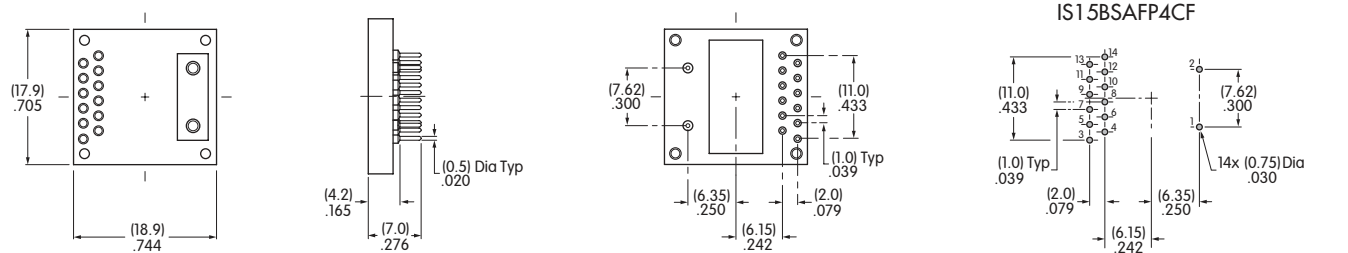

Compatible Part Numbers for AT9704-065F

LCD 64 x 32

IS15EBFP4RGB-09YN

LCD 64 x 32 Compact

IS15ESBFP4RGB

LCD 36 x 24

IS15BAFP4CF

LCD 36 x 24 Compact

IS15BSBFP4RGB

IS15BSAFP4CF

Note: AT9704-065F Socket may be used with the LCD 64 x 32 SmartDisplay by removing pins 3, 4, 11, 12, 13 and 14.