

NOTES:

1. MATERIALS AND FINISHES:  
 BODY, BULLET CONTACT, SLEEVE, INNER FERRULE  
 HEX NUT & LOCK WASHER - BRASS, GOLD PLATING  
 CONTACT - BeCu, GOLD PLATING  
 INSULATOR & INSULATOR DISC - PTFE, NATURAL  
 GASKET - SILICONE RUBBER, RED
2. ELECTRICAL:  
 A. IMPEDANCE: 50 OHM  
 B. FREQUENCY: DC - 6 GHz  
 C. VSWR: 1.30 MAX. @ DC - 3 GHz  
 1.40 MAX. @ 3 - 6 GHz  
 D. DIELECTRIC WITHSTANDING VOLTAGE: 500 VRMS, MIN.
3. MECHANICAL:  
 A. DURABILITY: 500 CYCLES, MIN.  
 B. TEMPERATURE RANGE: -65°C TO +165°C

4. PACKAGING:  
 A. QUANTITY: SINGLE PACK  
 B. MARKING: PACKAGING TO BE MARKED  
 "AMPHENOL RF, 901-10772 & DATE CODE"
5. CABLE ASSEMBLY INSTRUCTIONS:  
 A. TRIM CABLE AS SHOWN.  
 B. INSERT CABLE THROUGH INNER FERRULE AND PEEL BRAID BACK,  
 OVER INNER FERRULE  
 C. INSTALL SLEEVE AND INSULATOR DISC OVER CABLE, BOTTOMING ON  
 INNER FERRULE.  
 D. SOLDER BULLET CONTACT TO CABLE CENTER CONDUCTOR,  
 BOTTOMING ON INSULATOR DISC.  
 E. INSERT CABLE INTO CONNECTOR UNTIL IT BOTTOMS.  
 F. CRIMP BODY OVER INNER FERRULE USING 0.105" HEX.

6 SHOWS CABLE ENTRY DIMENSIONS.

REVISIONS				
REV	DESCRIPTION	DATE	ECN	BY
A	RELEASE TO MFG.	26-JAN-22	16090	SH

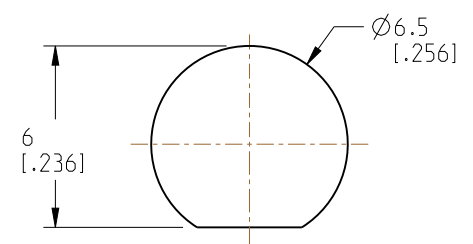

RECOMMENDED MOUNTING HOLE DIMENSIONS

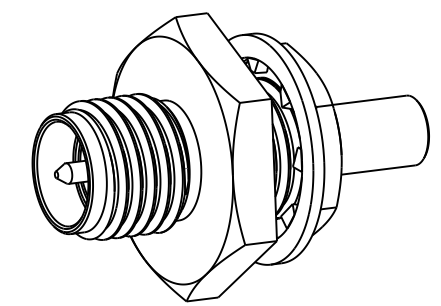

SCALE 3.000

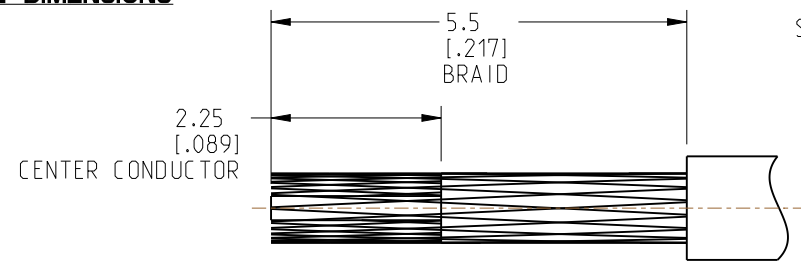

RECOMMENDED CABLE STRIPPING DIMENSIONS

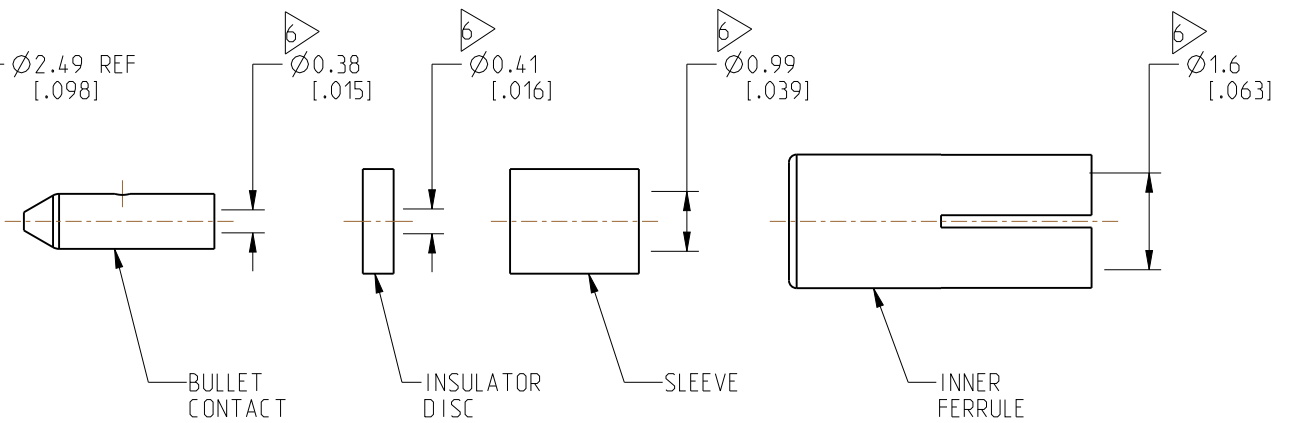
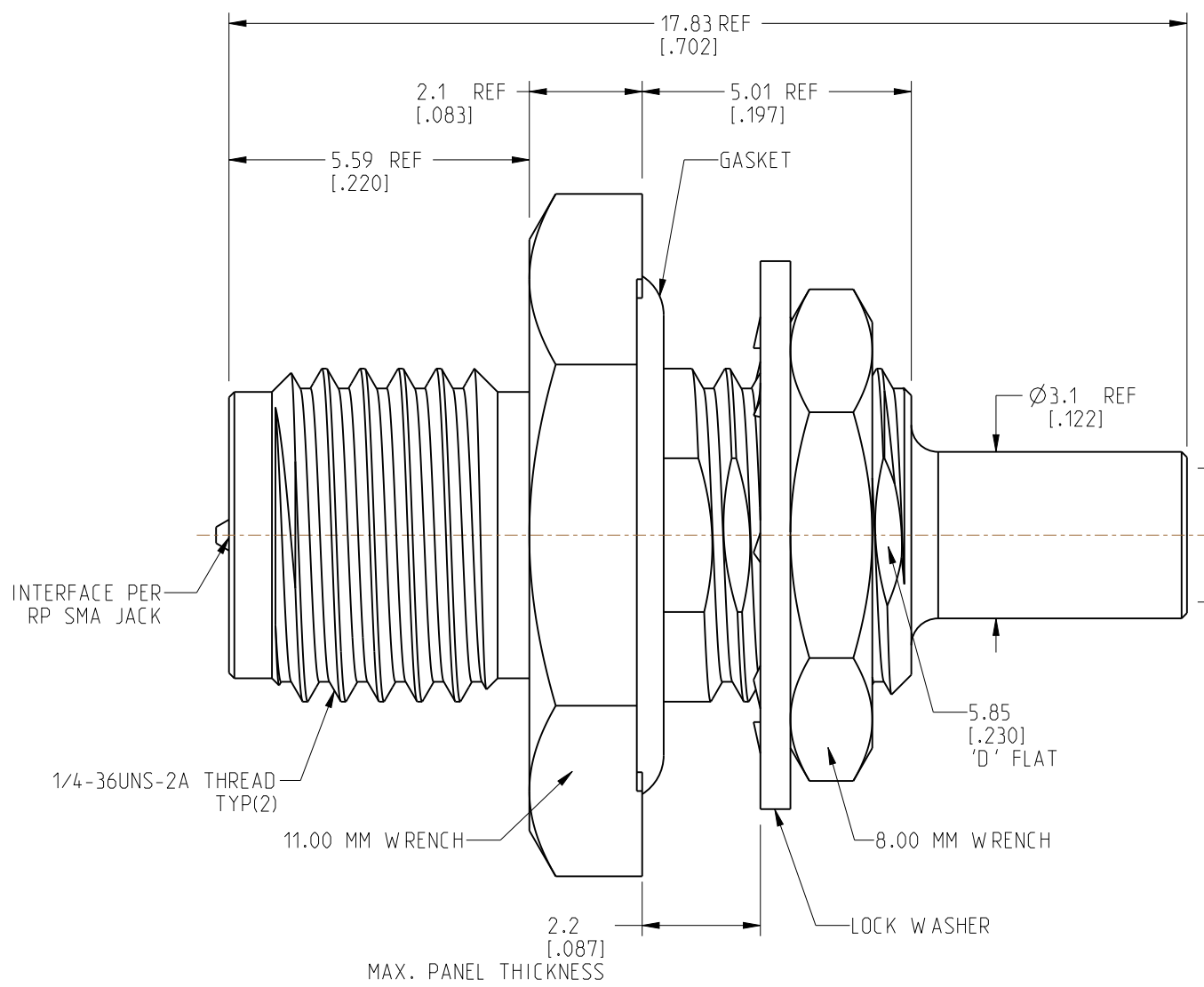

**CUSTOMER OUTLINE DRAWING**  
 ALL OTHER SHEETS ARE FOR INTERNAL USE ONLY

NOTICE: These drawings, specifications, or other data (1) are, and remain the property of Amphenol corp. (2) must be returned upon request; and (3) are confidential and not to be disclosed to any person other than those to whom they are given by Amphenol Corp. The furnishing of these drawings, specifications, or other data by Amphenol Corp., or to any other person to anyone for any purpose is not to be regarded by implication or otherwise in any manner licensing, granting rights to permitting such holder or any other person to manufacture, use or sell any product, process or design, patented or otherwise, that may in any way be related to or disclosed by said drawings, specifications, or other data.

UNLESS OTHERWISE SPECIFIED  
 DIMENSIONS ARE METRIC (INCHES) AND TOLERANCES ARE:  
 <0.5mm = ±0.05mm [-0.020 = ±0.002]  
 0.5 - 6mm = ±0.1mm [-0.020 - 0.236 = ±0.004]  
 >6.00 - 30mm = ±0.2mm [-0.236 - 1.181 = ±0.008]  
 >30.00 - 120mm = ±0.3mm [-1.181 - 4.725 = ±0.012]

ANGLES = ±1°

MATERIAL

ENGR.1 VIJAY N M ENGR.2 JACK LIANG DATE 07-JAN-21

TITLE  
 RP SMA STR BHD JACK  
 FRONT MOUNT FOR  
 1.37 MM CABLE

SHEET NO. 2 OF 2 SCALE: 8.0:1.0

**Amphenol RF**

SIZE	DRAWING NO. 901-10772	REV
	ITEM NO. 901-10772	A
	PART NO. 901-10772	