



CMOS OCTAL BUS TRANSCEIVER WITH ADJUSTABLE OUTPUT VOLTAGE, 3-STATE OUT- PUTS, 5 VOLT TOLERANT I/O

IDT74LVCC3245A

FEATURES:

- 0.5 MICRON CMOS Technology
- $V_{CCA} = 2.3V$ to $3.6V$
- $V_{CCB} = 3V$ to $5.5V$
- CMOS power levels ($0.4\mu W$ typ. static)
- Rail-to-rail output swing for increased noise margin
- All inputs, outputs, and I/O are 5V tolerant
- Supports hot insertion
- Available in SOIC, SSOP, QSOP, and TSSOP packages

DRIVE FEATURES:

- High Output Drivers: $\pm 24mA$
- Reduced system switching noise

APPLICATIONS:

- 5V and 3.3V mixed voltage systems
- Data communication and telecommunication systems

DESCRIPTION:

The LVCC3245A is manufactured using advanced dual metal CMOS technology. This 8-bit (octal) noninverting bus transceiver contains two separate supply rails. The B port is designed to track V_{CCB} , which accepts voltages from 3V to 5.5V, and the A port is designed to track V_{CCA} , which operates at 2.3V to 3.6V. This allows for translation from a 3.3V to a 5V system environment and vice-versa, or from a 2.5V to a 3.3V system environment, and vice-versa.

This LVCC3245A is ideal for asynchronous communication between two data buses (A and B). The device transmits data from A to B or from B to A, depending on the logic level at the direction-control (DIR) input. The output-enable (\overline{OE}) input can be used to disable the device so the buses are effectively isolated.

The LVCC3245A has been designed with a $\pm 24mA$ output driver. This driver is capable of driving a moderate to heavy load while maintaining speed performance.

FUNCTIONAL BLOCK DIAGRAM

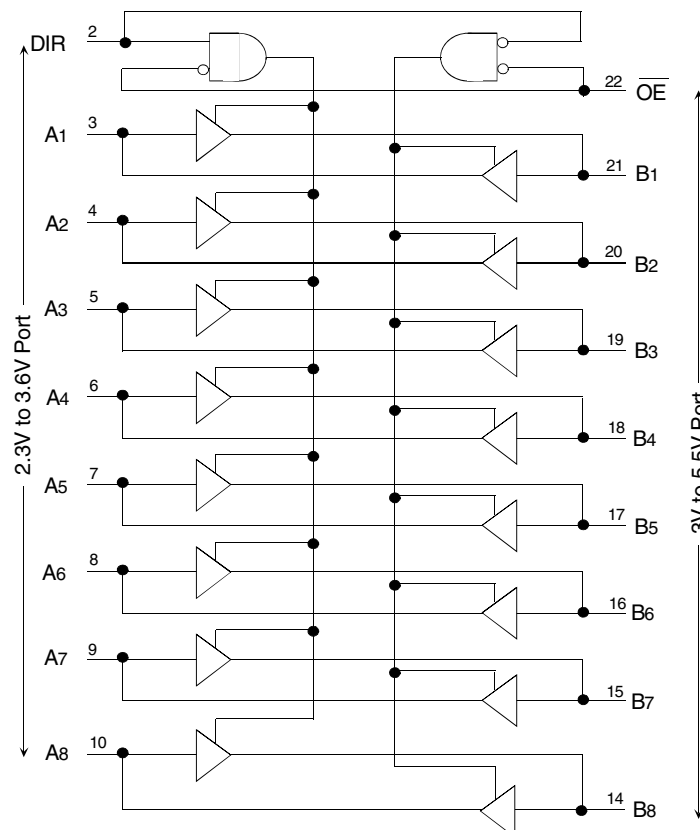

The IDT logo is a registered trademark of Integrated Device Technology, Inc.

INDUSTRIAL TEMPERATURE RANGE

JULY 2000

PIN CONFIGURATION

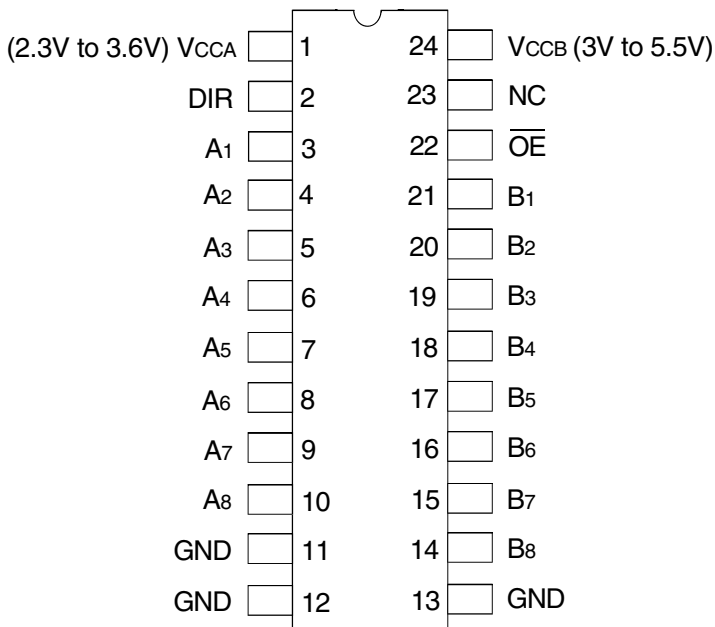

SOIC/ SSOP/ QSOP/ TSSOP
TOP VIEW

ABSOLUTE MAXIMUM RATINGS FOR V_{CCB} OR V_{CCB}(¹)

Symbol	Description	Max	Unit
V _{TERM}	Terminal Voltage with Respect to GND	-0.5 to +6	V
T _{STG}	Storage Temperature	-65 to +150	°C
I _{OUT}	DC Output Current	-50 to +50	mA
I _{IK} I _{OK}	Continuous Clamp Current, V _I < 0 or V _O < 0	-50	mA
I _{CC} I _{SS}	Continuous Current through each V _{CC} or GND	±100	mA

NOTE:

- Stresses greater than those listed under ABSOLUTE MAXIMUM RATINGS may cause permanent damage to the device. This is a stress rating only and functional operation of the device at these or any other conditions above those indicated in the operational sections of this specification is not implied. Exposure to absolute maximum rating conditions for extended periods may affect reliability.

CAPACITANCE (T_A = +25°C, F = 1.0MHz)

Symbol	Parameter ⁽¹⁾	Conditions	Typ.	Unit
C _{IN}	Input Capacitance	V _{IN} = 0V	4.5	pF
C _{I/O}	I/O Port Capacitance	V _{IN} = 0V	11	pF

NOTE:

- As applicable to the device type.

PIN DESCRIPTION

Pin Names	Description
\overline{OE}	Output Enable Input (Active LOW)
DIR	Direction Control Input
A _x	Port A Inputs or 3-State Outputs
B _x	Port B Inputs or 3-State Outputs
NC	No Internal Connection

FUNCTION TABLE⁽¹⁾

Inputs		Outputs
\overline{OE}	DIR	
L	L	Bus B Data to Bus A
L	H	Bus A Data to Bus B
H	X	High Z state

NOTE:

- H = HIGH Voltage Level
L = LOW Voltage Level
X = Don't Care

DC ELECTRICAL CHARACTERISTICS OVER OPERATING RANGE (A PORT)

Following Conditions Apply Unless Otherwise Specified:

Operating Condition: $T_A = -40^{\circ}\text{C}$ to $+85^{\circ}\text{C}$, $V_{CCA} = 2.3\text{V}$ to $3.6\text{V}^{(1)}$

Symbol	Parameter	Test Conditions		Min.	Typ. ⁽²⁾	Max.	Unit
V_{IH}	Input HIGH Voltage Level	$V_{OB} \leq 0.1\text{V}$ $V_{OB} \geq V_{CCB} - 0.1\text{V}$	$V_{CCA} = 2.3\text{V}$, $V_{CCB} = 3\text{V}$	1.7	—	—	V
			$V_{CCA} = 2.7\text{V}$ to 3.6V	2	—	—	
V_{IL}	Input LOW Voltage Level		$V_{CCA} = 2.3\text{V}$, $V_{CCB} = 3\text{V}$	—	—	0.7	V
			$V_{CCA} = 2.7\text{V}$ to 3.6V	—	—	0.8	
I_{IH} I_{IL}	Input Leakage Current	$V_{CCA} = 3.6\text{V}$	$V_i = 0$ to 5.5V	—	—	± 1	μA
I_{OZH} I_{OZL}	High Impedance Output Current (3-State Output pins)	$V_{CCA} = 3.6\text{V}$	$V_o = V_{CCA}$ or GND	—	—	± 5	μA
I_{OFF}	Input/Output Power Off Leakage	$V_{CCA} = 0\text{V}$, V_{IN} or $V_o \leq 5.5\text{V}$		—	—	± 50	μA
V_H	Input Hysteresis	$V_{CCA} = 3.3\text{V}$		—	100	—	mV
I_{CCL} I_{CCH} I_{CCZ}	Quiescent Power Supply Current	$V_{CCA} = 3.6\text{V}$	$V_{IN} = \text{GND}$ or V_{CC}	—	—	50	μA
ΔI_{CC}	Quiescent Power Supply Current Variation	One input at $V_{CCA} - 0.6$, other inputs at V_{CCA} or GND		—	—	500	μA

NOTES:

- $V_{CCB} = 3\text{V}$ to 5.5V .
- Typical values are at $V_{CC} = 3.3\text{V}$, $+25^{\circ}\text{C}$ ambient.
- This applies in the disabled state only.

DC ELECTRICAL CHARACTERISTICS OVER OPERATING RANGE (B PORT)

Following Conditions Apply Unless Otherwise Specified:

Operating Condition: $T_A = -40^{\circ}\text{C}$ to $+85^{\circ}\text{C}$, $V_{CCB} = 3\text{V}$ to $5.5\text{V}^{(1)}$

Symbol	Parameter	Test Conditions		Min.	Typ. ⁽²⁾	Max.	Unit
V_{IH}	Input HIGH Voltage Level	$V_{OA} \leq 0.1\text{V}$ $V_{OA} \geq V_{CCB} - 0.1\text{V}$	$V_{CCB} = 3\text{V}$ to 3.6V	2	—	—	V
			$V_{CCB} = 5.5\text{V}$	3.85	—	—	
V_{IL}	Input LOW Voltage Level		$V_{CCB} = 3\text{V}$ to 3.6V	—	—	0.8	V
			$V_{CCB} = 5.5\text{V}$	—	—	1.65	
I_{IH} I_{IL}	Input Leakage Current	$V_{CCB} = 3.6\text{V}$	$V_i = 0$ to 5.5V	—	—	± 1	μA
I_{OZH} I_{OZL}	High Impedance Output Current (3-State Output pins)	$V_{CCB} = 3.6\text{V}$	$V_o = V_{CCB}$ or GND	—	—	± 5	μA
I_{OFF}	Input/Output Power Off Leakage	$V_{CCB} = 0\text{V}$, V_{IN} or $V_o \leq 5.5\text{V}$		—	—	± 50	μA
V_H	Input Hysteresis	$V_{CCB} = 3.3\text{V}$		—	100	—	mV
I_{CCL} I_{CCH} I_{CCZ}	Quiescent Power Supply Current	$V_{CCB} = 3.6\text{V}$	$V_{IN} = \text{GND}$ or V_{CC}	—	—	50	μA
		$V_{CCB} = 5.5\text{V}$		—	—	80	
ΔI_{CC}	Quiescent Power Supply Current Variation	One input at $V_{CCB} - 2.1$ other inputs at V_{CCB} or GND		—	—	1.5	mA

NOTES:

- $V_{CCA} = 2.3\text{V}$ to 3.6V .
- Typical values are at $V_{CC} = 3.3\text{V}$, $+25^{\circ}\text{C}$ ambient.
- This applies in the disabled state only.

OUTPUT DRIVE CHARACTERISTICS, $V_{CCA} = 2.3V$ TO $3.6V$ (A PORT)

Symbol	Parameter	Test Conditions ⁽¹⁾			Min.	Max.	Unit
VOHA	Output HIGH Voltage (B port to A port)	$V_{CCA} = 3V$	$V_{CCB} = 3V$	$I_{OH} = -0.1mA$	2.9	—	V
		$V_{CCA} = 2.3V$	$V_{CCB} = 3V$	$I_{OH} = -8mA$	2	—	
		$V_{CCA} = 2.7V$	$V_{CCB} = 3V$	$I_{OH} = -12mA$	2.2	—	
		$V_{CCA} = 3V$	$V_{CCB} = 3V$		2.4	—	
		$V_{CCA} = 3V$	$V_{CCB} = 3V$	$I_{OH} = -24mA$	2.2	—	
		$V_{CCA} = 2.7V$	$V_{CCB} = 4.5V$		2	—	
VOLA	Output LOW Voltage (B port to A port)	$V_{CCA} = 3V$	$V_{CCB} = 3V$	$I_{OL} = 0.1mA$	—	0.1	V
		$V_{CCA} = 2.3V$	$V_{CCB} = 3V$	$I_{OL} = 8mA$	—	0.6	
		$V_{CCA} = 2.7V$	$V_{CCB} = 3V$	$I_{OL} = 12mA$	—	0.5	
		$V_{CCA} = 3V$	$V_{CCB} = 3V$	$I_{OL} = 24mA$	—	0.5	
		$V_{CCA} = 2.7V$	$V_{CCB} = 4.5V$		—	0.5	

NOTE:
1. V_{IH} and V_{IL} must be within the min. or max. range shown in the DC ELECTRICAL CHARACTERISTICS OVER OPERATING RANGE table for the appropriate V_{CC} range. $T_A = -40^{\circ}C$ to $+85^{\circ}C$, $V_{CCB} = 3V$ to $5.5V$.

OUTPUT DRIVE CHARACTERISTICS, $V_{CCB} = 3V$ TO $5.5V$ (B PORT)

Symbol	Parameter	Test Conditions ⁽¹⁾			Min.	Max.	Unit
VOHB	Output HIGH Voltage (A port to B port)	$V_{CCB} = 3V$	$V_{CCA} = 3V$	$I_{OH} = -0.1mA$	2.9	—	V
		$V_{CCB} = 3V$	$V_{CCA} = 2.3V$	$I_{OH} = -12mA$	2.4	—	
		$V_{CCB} = 3V$	$V_{CCA} = 2.7V$		2.4	—	
		$V_{CCB} = 3V$	$V_{CCA} = 3V$	$I_{OH} = -24mA$	2.2	—	
		$V_{CCB} = 4.5V$	$V_{CCA} = 2.7V$		3.2	—	
VOLB	Output LOW Voltage (A port to B port)	$V_{CCB} = 3V$	$V_{CCA} = 3V$	$I_{OL} = 0.1mA$	—	0.1	V
		$V_{CCB} = 3V$	$V_{CCA} = 2.3V$	$I_{OL} = 12mA$	—	0.4	
		$V_{CCB} = 3V$	$V_{CCA} = 3V$	$I_{OL} = 24mA$	—	0.5	
		$V_{CCB} = 4.5V$	$V_{CCA} = 3V$		—	0.5	

NOTE:
1. V_{IH} and V_{IL} must be within the min. or max. range shown in the DC ELECTRICAL CHARACTERISTICS OVER OPERATING RANGE table for the appropriate V_{CC} range. $T_A = -40^{\circ}C$ to $+85^{\circ}C$, $V_{CCA} = 2.3V$ to $3.6V$.

OPERATING CHARACTERISTICS, $T_A = 25^{\circ}C$

Symbol	Parameter	Test Conditions	$V_{CCA} = 3.3V, V_{CCB} = 5V$	Unit
			Typical	
CPD	Power Dissipation Capacitance per Transceiver Outputs enabled A to B	$C_L = 0pF, f = 10MHz$	38	pF
CPD	Power Dissipation Capacitance per Transceiver Outputs disabled B to A		36.5	

SWITCHING CHARACTERISTICS⁽¹⁾

Symbol	Parameter	V _{CCA} = 2.5V ± 0.2V		V _{CCA} = 2.7V to 3.6V				Unit
		V _{CCB} = 3.3V ± 0.3V		V _{CCB} = 5V ± 0.5V		V _{CCB} = 3.3V ± 0.3V		
		Min.	Max.	Min.	Max.	Min.	Max.	
t _{PHL}	Propagation Delay	1	9.4	1	6	1	7.1	ns
t _{PLH}	Ax to Bx	1	9.1	1	5.3	1	7.2	
t _{PHL}	Propagation Delay	1	11.2	1	5.8	1	6.4	ns
t _{PLH}	Bx to Ax	1	9.9	1	7	1	7.6	
t _{PZL}	Output Enable Time	1	13	1	8.1	1	9.2	ns
t _{PLZ}	\overline{OE} to Bx	1	12.8	1	8.4	1	9.9	
t _{PZL}	Output Enable Time	1	14.5	1	9.2	1	9.7	ns
t _{PLZ}	\overline{OE} to Ax	1	12.9	1	9.5	1	9.5	
t _{PLZ}	Output Disable Time	1	7.1	1	5.5	1	6.6	ns
t _{PHZ}	\overline{OE} to Ax	1	6.9	1	7.8	1	6.9	
t _{PLZ}	Output Disable Time	1	8.8	1	7.3	1	7.5	ns
t _{PHZ}	\overline{OE} to Bx	1	8.9	1	7	1	7.9	

NOTE:

1. See TEST CIRCUITS AND WAVEFORMS. T_A = - 40°C to + 85°C.

LOAD CIRCUIT AND VOLTAGE WAVEFORMS PARAMETER MEASUREMENT INFORMATION (A PORT)

$V_{CCA} = 2.5V \pm 0.2V$ and $V_{CCB} = 3.3V \pm 0.3V$

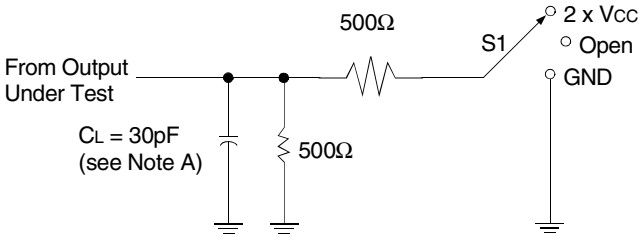

Load Circuit

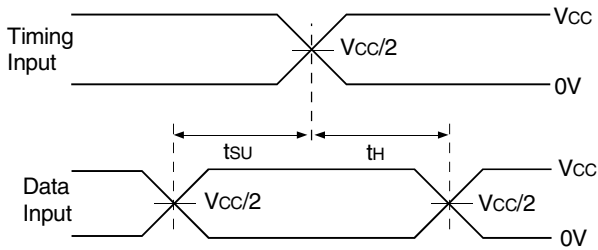

Voltage Waveforms Setup and Hold Times

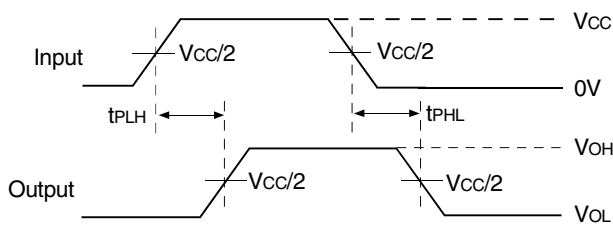

Voltage Waveforms Propagation Delay Times

TEST CONDITIONS

TEST	S1
t_{PD}	Open
t_{PLZ}/t_{PZL}	2 x V_{CC}
t_{PHZ}/t_{PZH}	GND

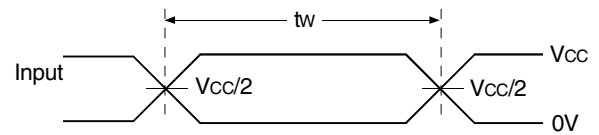

Voltage Waveforms Pulse Duration

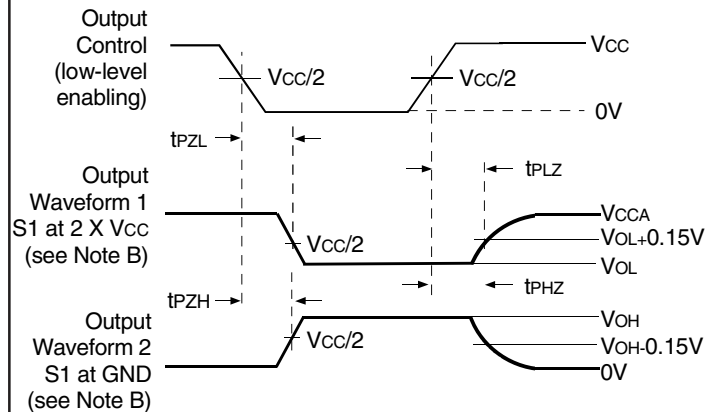

Voltage Waveforms Enable and Disable Times

NOTES:

- A. C_L includes probe and jig capacitance.
- B. Waveform 1 is for an output with internal conditions such that the output is LOW except when disabled by the output control. Waveform 2 is for an output with internal conditions such that the output is HIGH except when disabled by the output control.
- C. All input pulses are supplied by generators having the following characteristics: $PRR \leq 10MHz$; $Z_o = 50\Omega$; $t_r \leq 2ns$; $t_n \leq 2ns$.
- D. The outputs are measured one at a time with one transition per measurement.

LOAD CIRCUIT AND VOLTAGE WAVEFORMS PARAMETER MEASUREMENT INFORMATION (B PORT)

$$V_{CCA} = 2.5V \pm 0.2V \text{ and } V_{CCB} = 3.3V \pm 0.3V$$

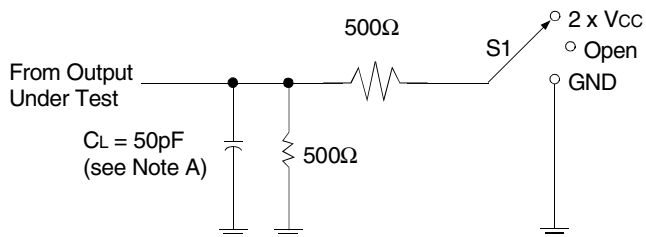

Load Circuit

TEST CONDITIONS

TEST	S1
t_{PD}	Open
t_{PLZ}/t_{PZL}	2 x V_{CC}
t_{PHZ}/t_{PZH}	GND

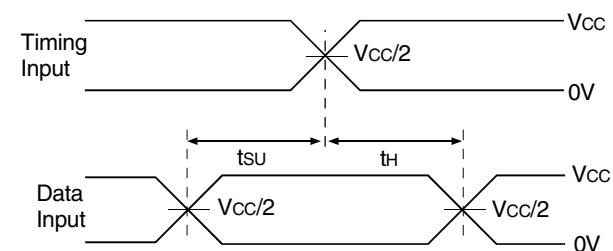

Voltage Waveforms Setup and Hold Times

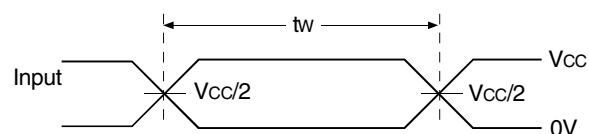

Voltage Waveforms Pulse Duration

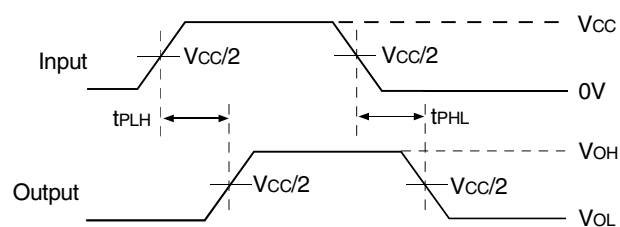

Voltage Waveforms Propagation Delay Times

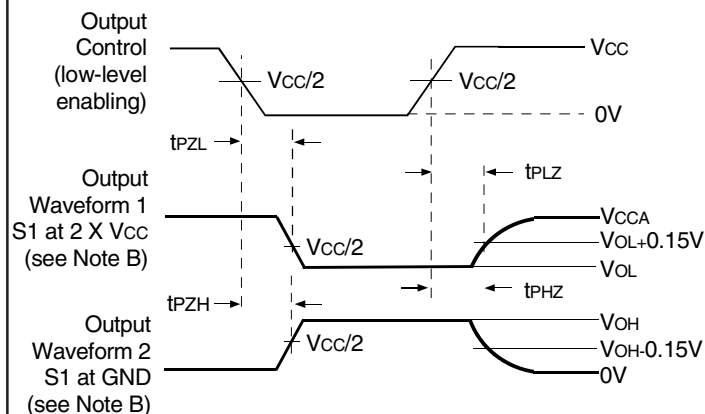

Voltage Waveforms Enable and Disable Times

NOTES:

- CL includes probe and jig capacitance.
- Waveform 1 is for an output with internal conditions such that the output is LOW except when disabled by the output control. Waveform 2 is for an output with internal conditions such that the output is HIGH except when disabled by the output control.
- All input pulses are supplied by generators having the following characteristics: $PRR \leq 10MHz$; $Z_o = 50\Omega$; $t_f \leq 2ns$; $t_r \leq 2ns$.
- The outputs are measured one at a time with one transition per measurement.

LOAD CIRCUIT AND VOLTAGE WAVEFORMS PARAMETER MEASUREMENT INFORMATION (A PORT)

$V_{CCA} = 3.6V$ and $V_{CCB} = 5.5V$

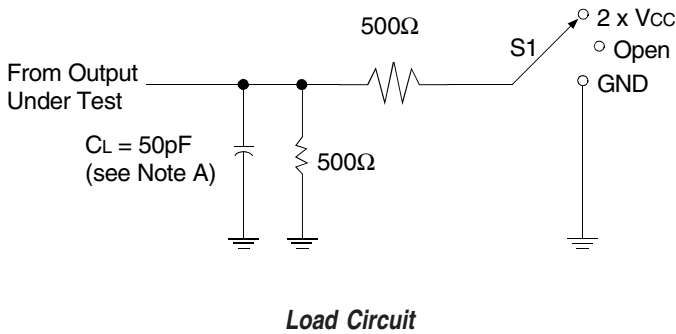

TEST CONDITIONS

TEST	S1
t_{PLH} / t_{PHL}	Open
t_{PLZ} / t_{PZL}	2 x V_{CC}
t_{PHZ} / t_{PZH}	GND

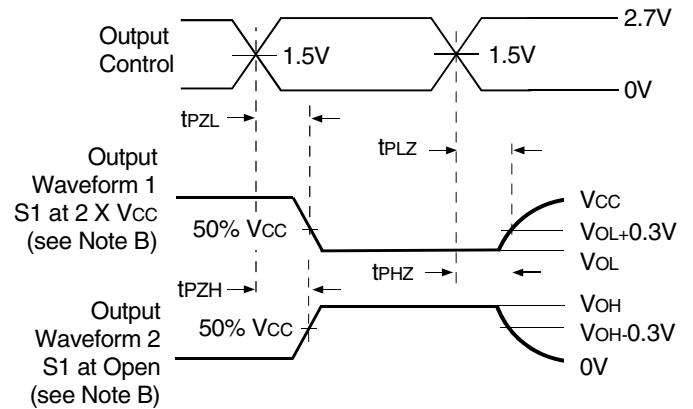
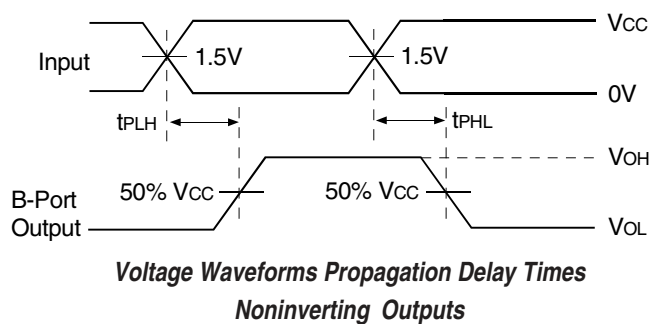
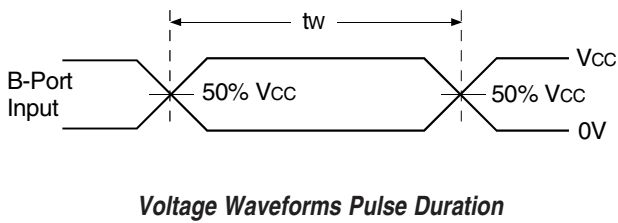

NOTES:

- C_L includes probe and jig capacitance.
- Waveform 1 is for an output with internal conditions such that the output is LOW except when disabled by the output control.
Waveform 2 is for an output with internal conditions such that the output is HIGH except when disabled by the output control.
- All input pulses are supplied by generators having the following characteristics: $PRR \leq 10MHz$; $Z_o = 50\Omega$; $t_r \leq 2.5ns$; $t_f \leq 2.5ns$.
- The outputs are measured one at a time with one transition per measurement.

LOAD CIRCUIT AND VOLTAGE WAVEFORMS PARAMETER MEASUREMENT INFORMATION (B PORT)

$V_{CCA} = 3.6V$ and $V_{CCB} = 5.5V$

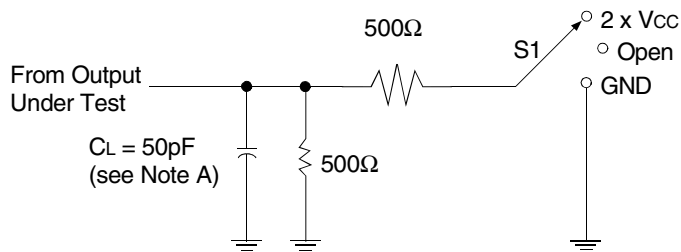

Load Circuit

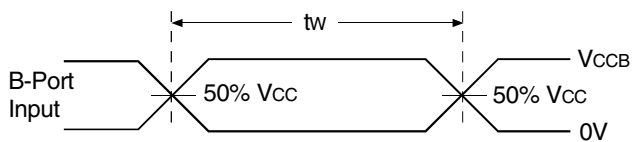

Voltage Waveforms Pulse Duration

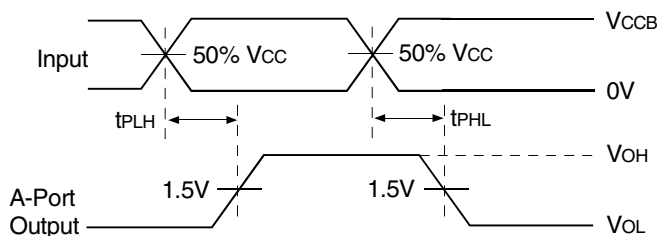

**Voltage Waveforms Propagation Delay Times
Noninverting Outputs**

TEST CONDITIONS

TEST	S1
t_{PLH}/t_{PHL}	Open
t_{PLZ}/t_{PZL}	2 x V_{CC}
t_{PHZ}/t_{PZH}	GND

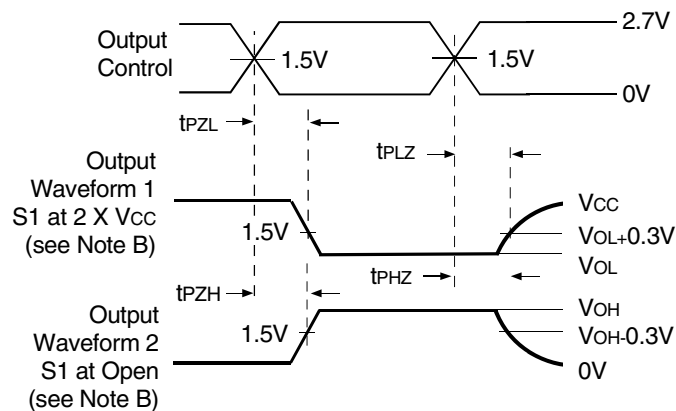

**Voltage Waveforms Enable and Disable Times
Low- and High-Level Enabling**

NOTES:

- CL includes probe and jig capacitance.
- Waveform 1 is for an output with internal conditions such that the output is LOW except when disabled by the output control.
Waveform 2 is for an output with internal conditions such that the output is HIGH except when disabled by the output control.
- All input pulses are supplied by generators having the following characteristics: $PRR \leq 10MHz$; $Z_o = 50\Omega$; $t_r \leq 2.5ns$; $t_f \leq 2.5ns$.
- The outputs are measured one at a time with one transition per measurement.

LOAD CIRCUIT AND VOLTAGE WAVEFORMS PARAMETER MEASUREMENT INFORMATION (A AND B PORT)

$V_{CCA} = \text{and } V_{CCB} = 3.6V$

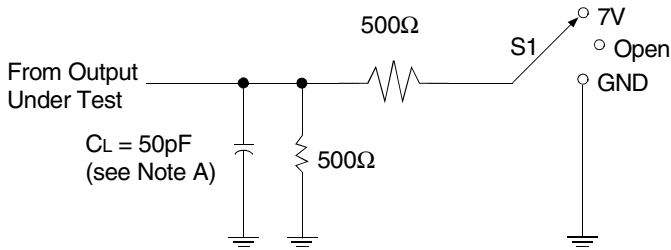

Load Circuit

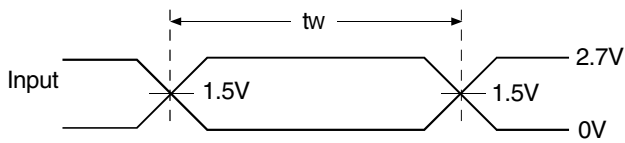

Voltage Waveforms Pulse Duration

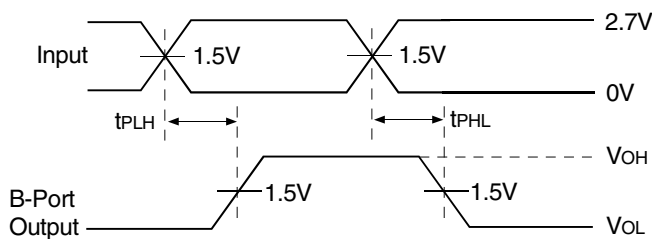

Voltage Waveforms Propagation Delay Times
Noninverting Outputs

TEST CONDITIONS

TEST	S1
t_{PLH} / t_{PHL}	Open
t_{PLZ} / t_{PZL}	7V
t_{PHZ} / t_{PZH}	GND

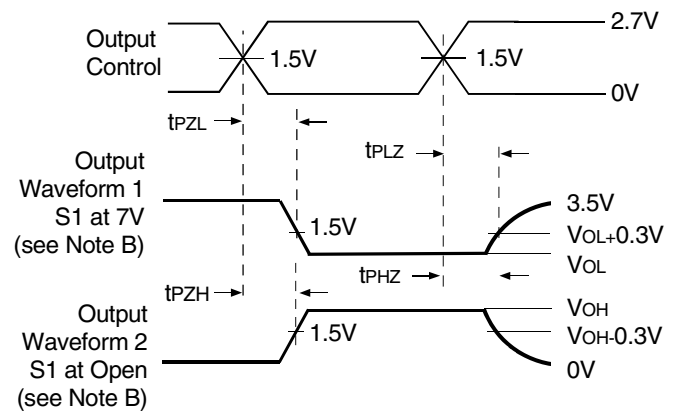

Voltage Waveforms Enable and Disable Times
Low- and High-Level Enabling

NOTES:

- C_L includes probe and jig capacitance.
- Waveform 1 is for an output with internal conditions such that the output is LOW except when disabled by the output control. Waveform 2 is for an output with internal conditions such that the output is HIGH except when disabled by the output control.
- All input pulses are supplied by generators having the following characteristics: PRR $\leq 10MHz$; $Z_o = 50\Omega$; $t_r \leq 2.5ns$; $t_f \leq 2.5ns$.
- The outputs are measured one at a time with one transition per measurement.

ORDERING INFORMATION

IDT	XX	LVC	X	XXXX	XX	
Temp. Range			Bus-Hold	Device Type	Package	
						SO Small Outline IC (gull wing)
						PY Shrink Small Outline Package
						Q Quarter Size Small Outline Package
						PG Thin Shrink Small Outline Package
						PGG TSSOP - Green
						C3245A Octal Bus Transceiver with Adjustable Output Voltage, 3-State Outputs, ±24mA
						Blank No Bus-Hold
						74 -40°C to +85°C



CORPORATE HEADQUARTERS
 6024 Silver Creek Valley Road
 San Jose, CA 95138

for SALES:
 800-345-7015 or 408-284-8200
 fax: 408-284-2775
 www.idt.com

for Tech Support:
 logichelp@idt.com