

PART NUMBER	SSL-LX5093USBC	REV.	B
DATE	E.C.N. NUMBER AND REVISION COMMENTS		REV.
05.14.01	E.C.N. #10BRDR. & REDRAWN.		A
03.28.11	E.C.N. #11703/10BRDR. & REDRAWN.		B

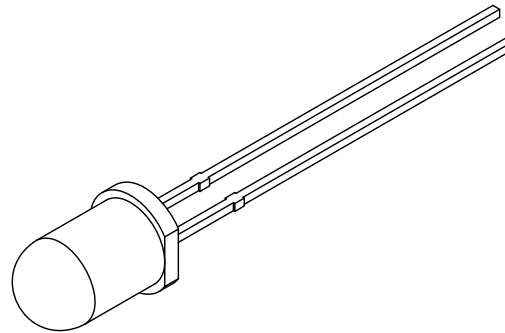
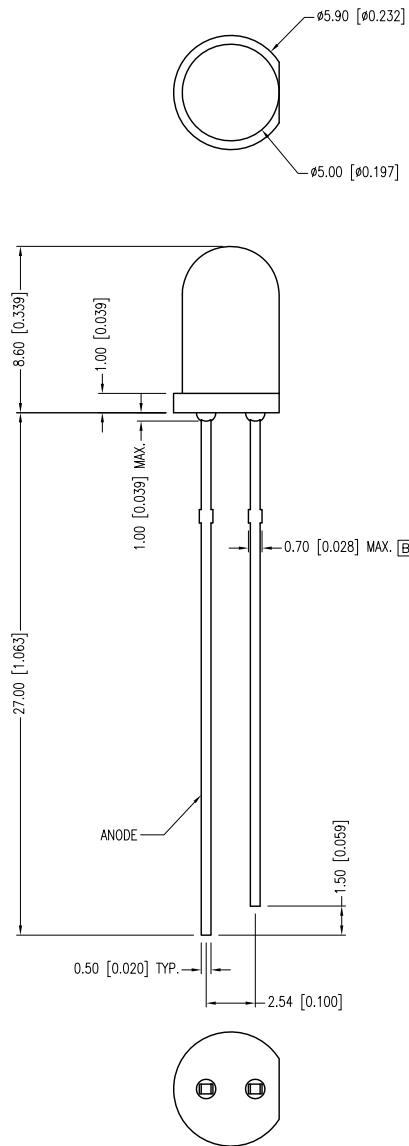

**[B] ELECTRO-OPTICAL CHARACTERISTICS  $T_a=25^{\circ}\text{C}$   $I_f=20\text{mA}$**

PARAMETER	MIN	TYP	MAX	UNITS	TEST COND
PEAK WAVELENGTH		470		nm	
FORWARD VOLTAGE		3.3	4.0	Vf	
REVERSE VOLTAGE	5.0			Vr	$I_f=100\mu\text{A}$
AXIAL INTENSITY	1900	3000		mcd	$I_f=20\text{mA}$
VIEWING ANGLE		16		2x theta	
EMITTED COLOR:	BLUE				
LENS FINISH:	WATER CLEAR				

**[B] LIMITS OF SAFE OPERATION AT 25°C**

PARAMETER	MAX	UNITS
PEAK FORWARD CURRENT*	150	mA
STEADY CURRENT	30	mA
POWER DISSIPATION	120	mW
DERATE FROM 25°C	-1.2	mW/°C
OPERATING TEMP.	-40 TO +85	°C
STORAGE TEMP.	-40 TO +85	°C
SOLDERING TEMP.	+260	°C
2.0mm FROM BODY	3	SEC.

\*  $t < 10\mu\text{s}$

CAUTION: STATIC SENSITIVE DEVICE  
FOLLOW PROPER E.S.D. HANDLING PROCEDURES  
WHEN WORKING WITH THIS PART.

\*UNLESS OTHERWISE SPECIFIED TOLERANCES PER DECIMAL PRECISION ARE: X=±1 (±0.039), X.X=±0.5 (±0.020), X.XX=±0.25 (±0.010), X.XXX=±0.127 (±0.005). LEAD SIZE=±0.05 (±0.002), LEAD LENGTH=±0.75 (±0.030). MIN= <sup>+DECIMAL PRECISION</sup> <sub>-0.00</sub> MAX.= <sup>+0.00</sup> <sub>-DECIMAL PRECISION</sub>



425 N. GARY AVE.  
CAROL STREAM, IL 60188-4900  
PHONE: +1.800.278.5666  
FAX: +1.630.315.2152  
WEB: WWW.LUMEX.COM  
MEMBER OF ITW PHOTONICS GROUP

QUASARBRITE T-5mm (T-1 3/4) 470nm ULTRA SUPER BLUE LED, WATER CLEAR LENS.

\*\*THE SPECIFICATIONS MAY CHANGE AT ANY TIME WITHOUT NOTICE DUE TO NEW MATERIALS OR PRODUCT IMPROVEMENT.\*\*

CONFIDENTIAL INFORMATION  
THE INFORMATION CONTAINED IN THIS DOCUMENT IS THE PROPERTY OF LUMEX INC. EXCEPT AS SPECIFICALLY AUTHORIZED IN WRITING BY LUMEX INC., THE HOLDER OF THIS DOCUMENT SHALL KEEP ALL INFORMATION CONTAINED HEREIN CONFIDENTIAL AND SHALL PROTECT SAME IN WHOLE OR IN PART FROM DISCLOSURE AND DISSEMINATION TO ALL THIRD PARTIES.

DATE:	03.28.11	DRAWN BY:	AB
PAGE:	1 OF 1	CHKD BY:	BC
SCALE:	NTS	APRVD BY:	BC
UNIT:	mm [INCH]		Ⓟ