

APPROVAL SHEET

WLSN073D Series SMD Unshielded Power Inductor



*Contents in this sheet are subject to change without prior notice.

Features

1. Unshielded power inductor.
2. Wide inductance range.

Applications

1. Inductor in DC/DC converter.
2. Use in STB 、 PDA 、 Notebook.

Shape and Dimension

Unit: mm

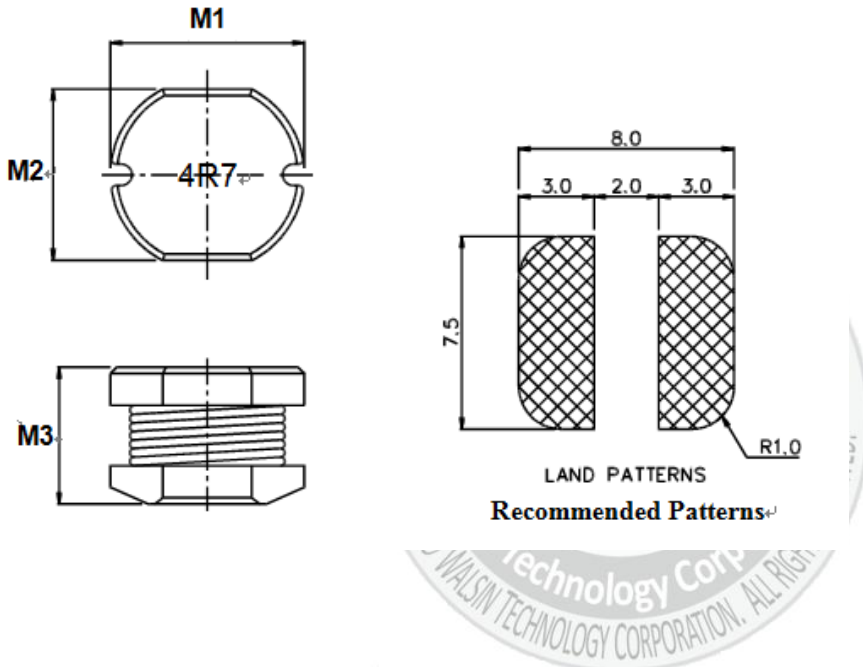

	DIM.	TOL.
M1	7.8	±0.3
M2	7.0	±0.3
M3	3.5	±0.5

Ordering Information

WL	SN	073D	Z0	M	1R0	L	B
Product Code	Series	Dimensions	Series extension	Tolerance	Value	Packing Code	
WL: Inductor	SMD Unshielded Power Inductors	7.8 * 7.0 mm	Z0:STD	M: ± 20% K : ± 10%	100 = 10.0uH 101 = 100uH	L=13" Reeled (Embossed tape)	B:STD

Electrical Characteristics

WLSN073D Series	Marking	L (uH)	Inductance Tolerance	Test Freq (KHz)	DCR (Ω) MAX.	Rated Current (A)
WLSN073DZ0M100LB	100	10	$\pm 20\%$	100	0.0803	1.44
WLSN073DZ0M120LB	120	12	$\pm 20\%$	100	0.0897	1.39
WLSN073DZ0M150LB	150	15	$\pm 20\%$	100	0.104	1.24
WLSN073DZ0M180LB	180	18	$\pm 20\%$	100	0.111	1.12
WLSN073DZ0M220LB	220	22	$\pm 20\%$	100	0.129	1.07
WLSN073DZ0M270LB	270	27	$\pm 20\%$	100	0.153	0.94
WLSN073DZ0M330LB	330	33	$\pm 20\%$	100	0.170	0.85
WLSN073DZ0M390LB	390	39	$\pm 20\%$	100	0.217	0.74
WLSN073DZ0M470LB	470	47	$\pm 20\%$	100	0.252	0.68
WLSN073DZ0K560LB	560	56	$\pm 10\%$	100	0.282	0.64
WLSN073DZ0K680LB	680	68	$\pm 10\%$	100	0.332	0.59
WLSN073DZ0K820LB	820	82	$\pm 10\%$	100	0.406	0.54
WLSN073DZ0K101LB	101	100	$\pm 10\%$	10	0.481	0.51
WLSN073DZ0K121LB	121	120	$\pm 10\%$	10	0.536	0.49
WLSN073DZ0K151LB	151	150	$\pm 10\%$	10	0.755	0.40
WLSN073DZ0K181LB	181	180	$\pm 10\%$	10	1.022	0.36
WLSN073DZ0K221LB	221	220	$\pm 10\%$	10	1.200	0.31
WLSN073DZ0K271LB	271	270	$\pm 10\%$	10	1.306	0.29
WLSN073DZ0K331LB	331	330	$\pm 10\%$	10	1.495	0.28

TOLERANCE : M: $\pm 20\%$, L: $\pm 15\%$, K: $\pm 10\%$

TEST INSTRUMENT: HP4285A/ Chroma 3302,1320.16502

* * Inductance drops no more than 20% at rated current applied or temperature rises $\Delta t \leq 40^\circ\text{C}$

* MSL:LEVEL 1

TYPICAL RoHS REFLOW PROFILE

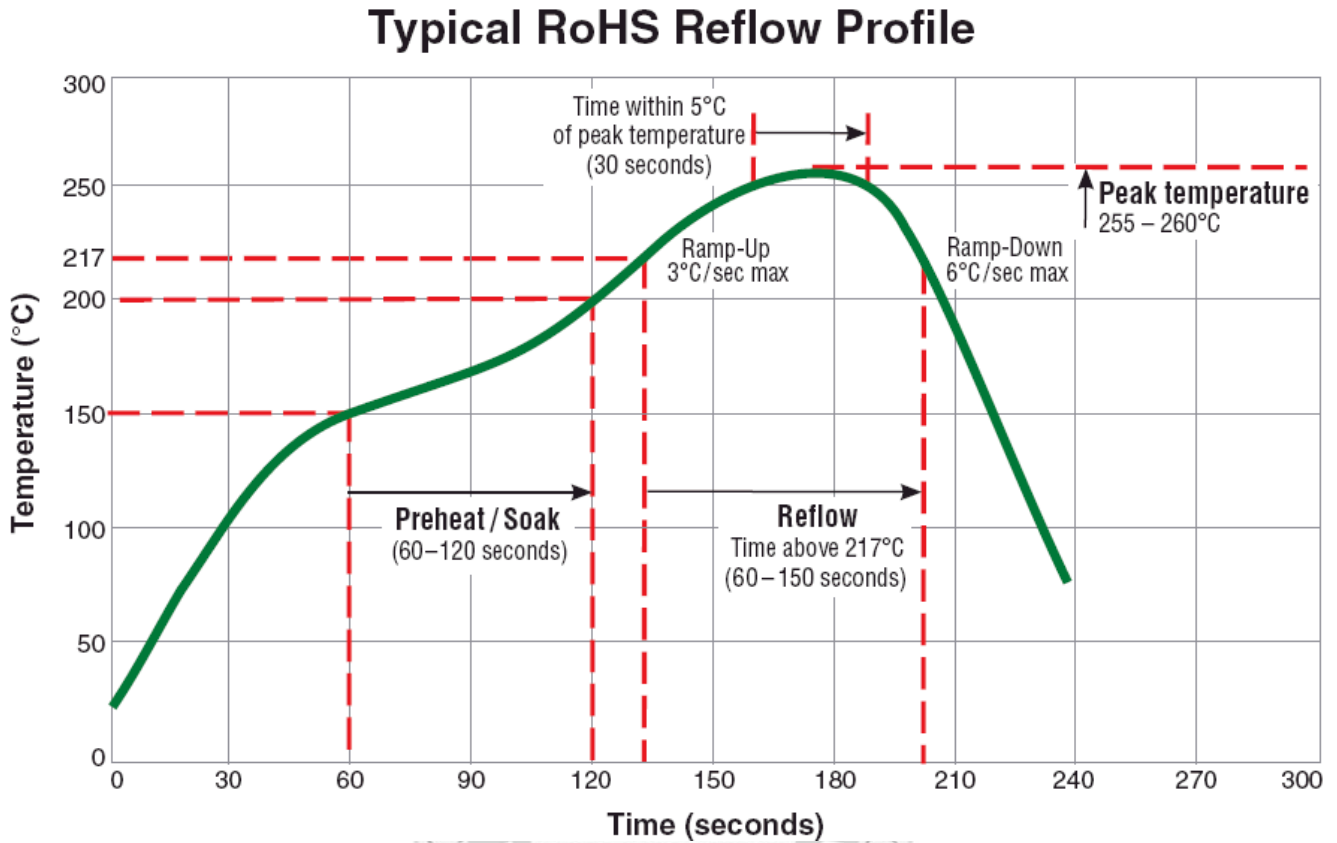

RELIABILITY PERFORMANCE

Reliability Experiment For Electrical

Test Item	Test Condition	Standard Source
Humidity Test	+40°C ± 2°C, humidity of 90% ± 5% (total 96 hours).	MIL-STD-202G Method 103B Test Condition B
High Temperature Test	1. Temperature: +125°C ± 2°C 2. Test time: 48 ± 2hrs	IEC 68-2 Test Condition B
Low Temperature Test	1. Temperature: -40°C ± 2°C 2. Test time: 48 ± 2hrs	IEC 68-2 Test Condition A
Thermal Shock	+125°C ± 5°C (30 minutes) ~ -40 ± 5°C (30 minutes), temperature switch time: 5 minutes (total 50 cycles).	MIL-STD-202G Method 107G Test Condition B-2
Life Test	+70°C ± 5°C (250Hours)	MIL-STD-202G Method 108A Test Condition B

Reliability Experiment For Physical

Test Item	Test Condition	Standard Source
Vibration Test	10-55-10HZ, amplitude: 1.5mm, direction: X, Y, Z axes, each axis 2 hours (total 6 hours).	MIL-STD-202G Method 201A
Solder Heat Resistance Test	IR/convection reflow: Peak Temp 250 ± 5°C for 5Sec in air, Through 2 Cycle. Temperature Ramp: +1~4°C/sec; Above 183°C, must keep 90 s - 120 s	MIL-STD-202G Method 210F Test Condition (Reflow)
Solder Ability Test	Soak in 245 °C solder pot of 3Sec, PAD must have 95% above coverage.	J-STD-003B

Tape & Reel Packaging Dimensions:

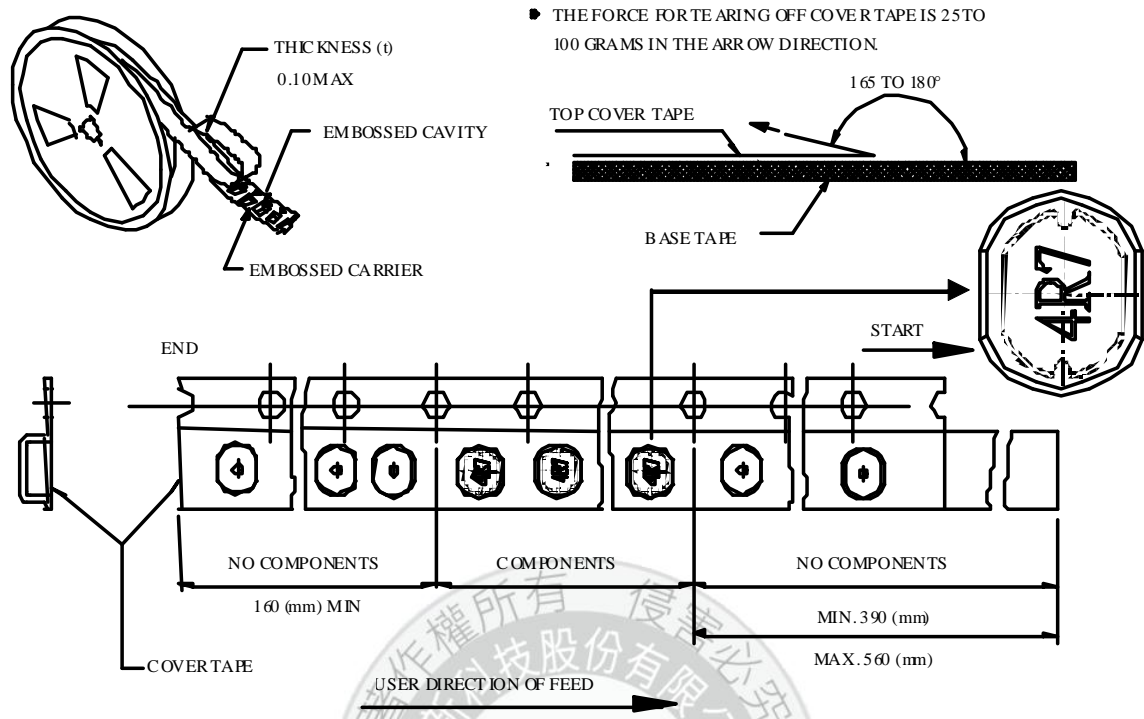

THE FORCE FOR TEARING OFF COVER TAPE IS 25 TO 100 GRAMS IN THE ARROW DIRECTION

■ CARRIER TAPE REELS (mm)

MATERIAL: PLASTIC

■ DIMENSIONS OF CARRIER TAPE (mm)

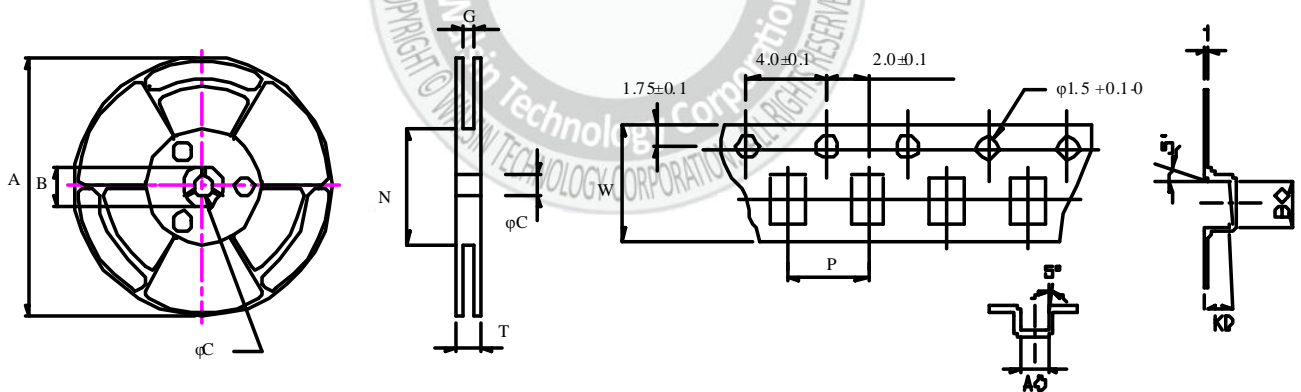

	A	B	C	G	N	P	T	W	t	AO	BO	KO
DIM.	340	21.0	13	16.4	100	12.0	22.4	16.0	0.35	7.3	8.0	4.3
TOL.	MAX	±0.8	±0.5	±0.2	MIN.	±0.10	MAX.	±0.3	±0.05	±0.10	±0.10	±0.10

Quantity per reel : 1K pcs