

REV.	DESCRIPTION	DATE	APPROVED
A	Engineering Update w/o Changes	03/01/04	M. C.

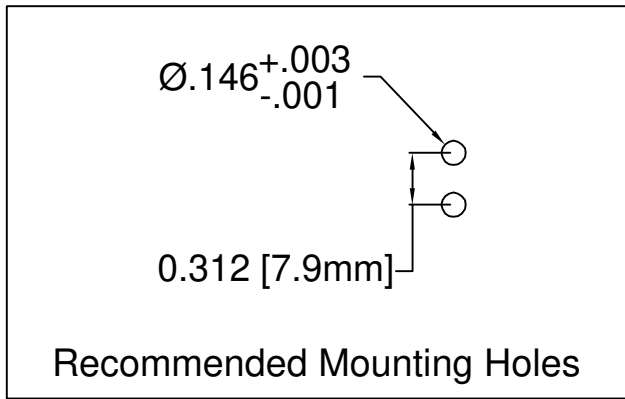
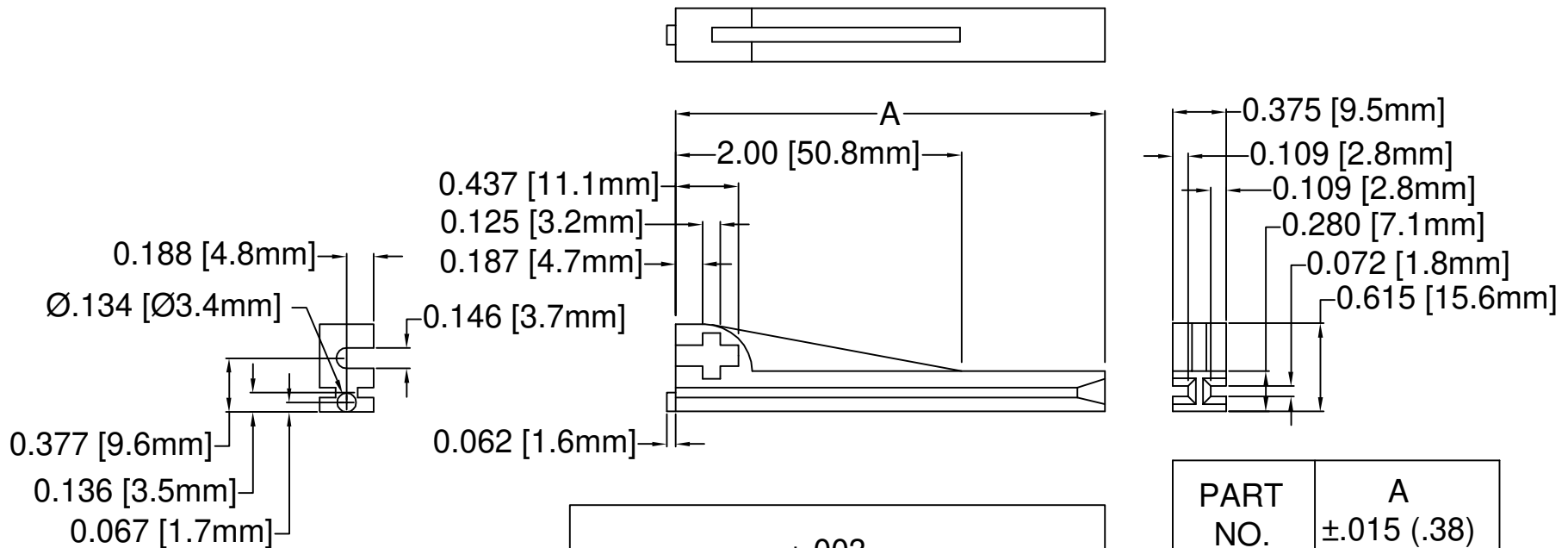

PART NO.	A
VG3-3	±.015 (.38)
VG3-35	3.0 (76.2)
VG3-4	3.5 (88.9)
VG3-45	4.0 (101.6)
VG3-5	4.5 (114.3)
VG3-55	5.0 (127.0)
VG3-6	5.5 (139.7)
VG3-6	6.0 (152.4)

2. MATERIAL: NYLON 6, 10% GLASS, 94V-0, BLACK. BIVAR MATERIAL CODE 12-BK. RTP 299A X 59354CFR, BLACK OR MODIFIED PLASTICS MN6-FG10SE BK.
1. GENERAL SPECIFICATIONS: BIVAR MOLDED COMPONENT SPECIFICATION BV00-E101.

STANDARD TOLERANCE (UNLESS OTHERWISE SPECIFIED)	
DECIMALS	ANGULAR
.X ±.1	X° ± 1°
.XX ±.01	
.XXX ±.005	

**BIVAR®**  
 4 THOMAS, IRVINE, CA. 92618  
 TEL: (949) 951-8808 FAX: (949) 951-3974

**TITLE:** VERT-O-GUIDE

<b>DESIGNED:</b> Shane Irving	<b>DATE:</b> 11/22/00	<b>PART NO:</b> VG3-XX	<b>REVISION:</b> A
<b>CHECKED:</b> D. Green	<b>DATE:</b> 03/01/04	<b>CAGE CODE :</b> 32559	<b>SHEET #</b> 1 <b>OF</b> 1

CAD GENERATED DOCUMENT, DO NOT MEASURE DRAWING.