

THIS DRAWING IS UNPUBLISHED. RELEASED FOR PUBLICATION  
 © COPYRIGHT - By - ALL RIGHTS RESERVED.

LOC	DIST	REVISIONS					
		P	LTR	DESCRIPTION	DATE	DWN	APVD
		H2		REVISED PER ECO-11-004587	11MAR11	RK	HMR

D

C

B

A

-	-	-	-	-	-	-	-	-	-	-	-	-	-	-	-	-	-	180.7	188.2	18	1-1546306-8	
-	-	-	-	-	-	-	-	-	-	-	-	-	-	-	-	-	-	-	171.2	178.7	17	1-1546306-7
-	-	-	-	-	-	-	-	-	-	-	-	-	-	-	-	-	-	-	161.7	169.2	16	1-1546306-6
△△△△	-	-	-	-	-	-	-	-	-	-	-	-	-	-	-	-	-	-	152.2	159.7	15	6-1546306-2
-	-	-	-	-	-	-	-	-	-	-	-	-	-	-	-	-	-	-	152.2	159.7	15	1-1546306-5
-	-	-	-	-	-	-	-	-	-	-	-	-	-	-	-	-	-	-	142.7	150.2	14	1-1546306-4
-	-	-	-	-	-	-	-	-	-	-	-	-	-	-	-	-	-	-	133.2	140.7	13	1-1546306-3
△△	-	-	-	-	-	-	-	-	-	-	-	-	-	-	-	-	-	-	123.7	131.2	12	4-1546306-0
△△	-	-	-	-	-	-	-	-	-	-	-	-	-	-	-	-	-	-	123.7	131.2	12	3-1546306-3
-	-	-	-	-	-	-	-	-	-	-	-	-	-	-	-	-	-	-	123.7	131.2	12	1-1546306-2
△	-	-	-	11	-	-	-	-	-	-	-	-	-	-	-	-	-	-	114.2	121.7	11	5-1546306-2
△△	-	-	-	-	2	-	-	-	-	-	-	11	-	-	-	-	-	-	114.2	121.7	11	3-1546306-4
△	-	-	-	-	-	-	-	-	-	-	-	11	-	-	-	-	-	-	114.2	121.7	11	3-1546306-1
-	-	-	-	-	-	-	-	-	-	-	-	-	-	-	-	-	-	-	114.2	121.7	11	1-1546306-1
△	-	-	-	-	-	-	-	-	-	-	10	3	-	-	-	-	-	-	104.7	112.2	10	6-1546306-0
△△	-	-	-	-	-	-	-	-	-	-	-	-	-	-	-	-	-	-	104.7	112.2	10	5-1546306-8
-	-	-	-	-	-	-	-	-	-	-	-	-	-	-	-	-	-	-	104.7	112.2	10	1-1546306-0
△△△	-	4	9	-	-	-	-	-	-	-	-	-	-	-	-	-	-	-	95.2	102.7	9	6-1546306-3
△△	-	-	-	-	-	-	-	-	-	-	-	-	-	-	-	-	-	-	95.2	102.7	9	5-1546306-6
-	-	-	-	-	-	-	-	-	-	-	-	-	-	-	-	-	-	-	95.2	102.7	9	1546306-9
-	-	-	-	-	-	-	-	-	-	-	8	-	-	-	-	-	-	-	85.7	93.2	8	5-1546306-9
△△	-	-	-	-	-	-	-	-	-	-	-	-	-	-	-	-	-	-	85.7	93.2	8	3-1546306-9
-	-	-	-	-	-	-	-	-	-	-	-	-	-	-	-	-	-	-	85.7	93.2	8	1546306-8
△△	-	-	-	-	-	-	-	-	-	-	-	-	-	-	-	-	-	-	76.2	83.7	7	5-1546306-5
△	-	-	-	-	1	-	-	-	-	7	-	-	-	-	-	-	-	-	76.2	83.7	7	5-1546306-0
-	-	-	-	-	-	-	-	-	-	-	-	-	-	-	-	7	7	7	76.2	83.7	7	4-1546306-5
△	-	-	-	-	-	-	-	-	-	-	-	-	-	-	-	-	-	-	76.2	83.7	7	3-1546306-7
-	-	-	-	-	-	-	-	-	-	-	-	-	-	-	-	-	-	-	76.2	83.7	7	1546306-7
△△	-	-	-	-	-	-	-	-	-	-	-	-	-	-	-	-	-	-	66.7	74.2	6	5-1546306-4
△△	-	-	-	-	-	-	-	-	-	-	-	-	-	-	-	-	-	-	66.7	74.2	6	4-1546306-9
-	-	-	-	-	-	-	-	-	-	-	-	-	-	-	-	-	-	-	66.7	74.2	6	4-1546306-8
-	-	-	-	-	-	-	-	-	-	-	-	-	-	-	-	6	6	6	66.7	74.2	6	4-1546306-4
△	-	-	-	-	-	-	-	-	-	-	-	-	-	-	-	-	-	-	66.7	74.2	6	3-1546306-6
-	-	-	-	-	-	-	-	-	-	-	-	-	-	-	-	-	-	-	66.7	74.2	6	1546306-6
△	-	-	-	-	-	-	-	-	-	-	5	-	-	-	-	-	-	-	57.2	64.7	5	5-1546306-7
△	-	5	5	-	-	-	-	-	-	-	-	-	-	-	-	-	-	-	57.2	64.7	5	5-1546306-3
△△ SCREW ON ONE SIDE	-	-	-	-	-	-	-	-	-	-	-	-	-	-	-	-	-	-	57.2	64.7	5	4-1546306-7
-	-	-	-	-	-	-	-	-	-	-	-	-	-	-	-	5	5	5	57.2	64.7	5	4-1546306-3
△	-	-	-	-	-	-	-	-	-	-	-	-	-	-	-	-	-	-	57.2	64.7	5	3-1546306-5
-	-	-	-	-	-	-	-	-	-	-	-	-	-	-	-	-	-	-	57.2	64.7	5	1546306-5
△△	-	-	-	-	-	-	-	-	-	-	-	-	-	-	-	-	-	-	47.7	55.2	4	4-1546306-2
-	-	-	-	-	-	-	-	-	-	-	-	-	-	-	-	-	-	-	47.7	55.2	4	3-1546306-8
-	-	-	-	-	-	-	-	-	-	-	-	-	-	-	-	-	-	-	47.7	55.2	4	1546306-4
-	3	3	-	-	-	-	-	-	-	-	-	-	-	-	-	-	-	-	38.2	45.7	3	6-1546306-1
-	-	-	-	-	-	-	-	-	-	-	-	-	-	-	-	-	-	-	38.2	45.7	3	5-1546306-1
-	-	-	-	-	-	-	-	-	-	-	-	-	-	-	-	-	-	-	38.2	45.7	3	1546306-3
△	-	-	-	-	-	-	-	-	-	-	2	2	2	-	-	-	-	-	28.7	36.2	2	4-1546306-6
-	-	-	-	-	-	-	-	-	-	-	-	-	-	-	-	-	-	-	28.7	36.2	2	4-1546306-1
-	-	-	-	-	-	-	-	-	-	-	-	-	-	-	-	-	-	-	28.7	36.2	2	1546306-2

NOTES	13	12	11	10	9	8	7	6	5	4	3	2	1	DIM B	DIM A	NO. OF POS.	PART NO.
	QC TAB .187 SS FLAT	QC TAB .187 SS FLAT	QC TAB .187 SS 90°	JUMPER	QC TAB DBL SIDE 90° .250	QC TAB DBL SIDE 45° .250	QC TAB DBL SIDE FLAT .250	QC TAB DBL SIDE 90° .187	QC TAB DBL SIDE 45° .187	QC TAB DBL SIDE FLAT .187	QC TAB SGL SIDE .250	QC TAB SGL SIDE 45° .250	QC TAB SGL SIDE FLAT .250				

THIS DRAWING IS A CONTROLLED DOCUMENT.		DWN S SCHLEGEL 20AUG2002	TE Connectivity	
DIMENSIONS: MM		CHK C RICHARD 8/20/02		
TOLERANCES UNLESS OTHERWISE SPECIFIED:		APVD C RICHARD 8/20/02	NAME 9.50MM (.374) DBL ROW BARRIER STRIP W/O WASHER	
0 PLC ± -		PRODUCT SPEC	SIZE	
1 PLC ± 0.3		APPLICATION SPEC	CAGE CODE	
2 PLC ± 0.25			DRAWING NO	
3 PLC ± -			RESTRICTED TO	
4 PLC ± -			SCALE	
ANGLES ± 2°			SHEET	
MATERIAL	FINISH	WEIGHT	REV	
			CUSTOMER DRAWING	
			SCALE NTS SHEET 1 OF 3 REV H2	

THIS DRAWING IS UNPUBLISHED. RELEASED FOR PUBLICATION  
 © COPYRIGHT - By - ALL RIGHTS RESERVED.

LOC		DIST		REVISIONS			
P	LTR	DESCRIPTION	DATE	DWN	APVD		
-	-	SEE SHEET 1	-	-	-		

PHYSICAL PROPERTIES:  
 HOUSING MATERIAL: THERMOPLASTIC, PC  
 FLAMMABILITY: UL94V-0 COLOR: BLACK  
 MAX BOW/WARP: .0056 IN/IN.

TERMINAL:  
 TERMINALS: BRASS, TIN PLATED  
 SCREWS: 6-32, STEEL, NICKEL PLATED

MECHANICAL:  
 PITCH (TERMINAL SPACING): 9.50mm(.374")  
 WIRE RANGE: 12-22 AWG  
 RECOMMENDED TIGHTENING TORQUE: 12IN-LBS MAX.

ELECTRICAL PROPERTIES:  
 MAXIMUM CURRENT: 20A  
 OPERATING VOLTAGE: 300V

ENVIRONMENTAL PROPERTIES:  
 OPERATING TEMP RANGE: -40°C TO +120°C.

- 1 SEE FIGURE.
- 2 MARKED WITH WHITE INK.
- 3 PRELIMINARY PART NUMBER.
- 4 SCREWS AND TERMINALS ARE NICKEL PLATED BRASS.
- 5 STAINLESS STEEL SCREWS.
- 6 SCREWS ARE NICKEL PLATED BRASS.
- 7 WIRE CLAMP SCREWS TO BE USED ONLY ON SIDE OPPOSITE QC TABS.
- 8 TE CONNECTIVITY LOGO LOCATED APPROXIMATE AREA SHOWN.

-- SELECT LOAD CHART --

-	-	4-5,5-6	-	-	-	-	ALL	-	-	-	-	11	3-1546306-4												
-	-	-	-	-	-	ALL	1-3	-	-	-	-	10	6-1546306-0												
-	-	1,2	-	-	ALL	-	-	-	-	-	-	7	5-1546306-0												
-	-	-	-	1	ALL	-	-	-	-	-	-	6	4-1546306-9												
12	QC TAB .187 SS FLAT	11	QC TAB .187 SS 90°	10	JUMPER	9	QC TAB DBL SIDE 90° .250	8	QC TAB DBL SIDE 45° .250	7	QC TAB DBL SIDE FLAT .250	6	QC TAB DBL SIDE 90° .187	5	QC TAB DBL SIDE 45° .187	4	QC TAB DBL SIDE FLAT .187	3	QC TAB SGL SIDE 90° .250	2	QC TAB SGL SIDE 45° .250	1	QC TAB SGL SIDE FLAT .250	NO. OF POS.	PART NUMBER
POSITIONS LOADED																									

-	-	-	-	-	-	-	-	-	-	-	-	-	-	-	-	-	-	294.7	302.2	30	3-1546306-0									
-	-	-	-	-	-	-	-	-	-	-	-	-	-	-	-	-	-	285.2	292.7	29	2-1546306-9									
-	-	-	-	-	-	-	-	-	-	-	-	-	-	-	-	-	-	275.7	283.2	28	2-1546306-8									
-	-	-	-	-	-	-	-	-	-	-	-	-	-	-	-	-	-	266.2	273.7	27	2-1546306-7									
-	-	-	-	-	-	-	-	-	-	-	-	-	-	-	-	-	-	256.7	264.2	26	2-1546306-6									
-	-	-	-	-	-	-	-	-	-	-	-	-	-	-	-	-	-	247.2	254.7	25	2-1546306-5									
-	-	-	-	-	-	-	-	-	-	-	-	-	-	-	-	-	-	237.7	245.2	24	2-1546306-4									
-	-	-	-	-	-	-	-	-	-	-	-	-	-	-	-	-	-	228.2	235.7	23	2-1546306-3									
-	-	-	-	-	-	-	-	-	-	-	-	-	-	-	-	-	-	218.7	226.2	22	2-1546306-2									
-	-	-	-	-	-	-	-	-	-	-	-	-	-	-	-	-	-	209.2	216.7	21	2-1546306-1									
1	SPL MARKING	-	-	-	-	-	-	-	-	-	-	-	-	-	-	-	-	199.7	207.2	20	3-1546306-2									
-	-	-	-	-	-	-	-	-	-	-	-	-	-	-	-	-	-	199.7	207.2	20	2-1546306-0									
-	-	-	-	-	-	-	-	-	-	-	-	-	-	-	-	-	-	190.2	197.7	19	1-1546306-9									
NOTES	13	QC TAB .187 SS FLAT	12	QC TAB .187 SS FLAT	11	QC TAB .187 SS 90°	10	JUMPER	9	QC TAB DBL SIDE 90° .250	8	QC TAB DBL SIDE 45° .250	7	QC TAB DBL SIDE FLAT .250	6	QC TAB DBL SIDE 90° .187	5	QC TAB DBL SIDE 45° .187	4	QC TAB DBL SIDE FLAT .187	3	QC TAB SGL SIDE 90° .250	2	QC TAB SGL SIDE 45° .250	1	QC TAB SGL SIDE FLAT .250	DIM B	DIM A	NO. OF POS.	PART NO.

THIS DRAWING IS A CONTROLLED DOCUMENT.		DWN S SCHLEGEL 20AUG2002	 TE Connectivity	
DIMENSIONS: MM		CHK C RICHARD 8/20/02		
TOLERANCES UNLESS OTHERWISE SPECIFIED:		APVD C RICHARD 8/20/02	NAME 9.50MM (.374) DBL ROW BARRIER STRIP W/O WASHER	
0 PLC ± - 1 PLC ± 0.3 2 PLC ± 0.25 3 PLC ± - 4 PLC ± - ANGLES ± 2°		PRODUCT SPEC -	SIZE A2	
MATERIAL		APPLICATION SPEC -	CAGE CODE 00779	DRAWING NO 1546306
FINISH		WEIGHT -	RESTRICTED TO -	SCALE NTS
		CUSTOMER DRAWING	SHEET 2 of 3	REV H2

THIS DRAWING IS UNPUBLISHED. RELEASED FOR PUBLICATION  
 © COPYRIGHT - By - ALL RIGHTS RESERVED.

LOC		DIST		REVISIONS			
P	LTR	DESCRIPTION	DATE	DWN	APVD		
-	-	SEE SHEET 1	-	-	-		

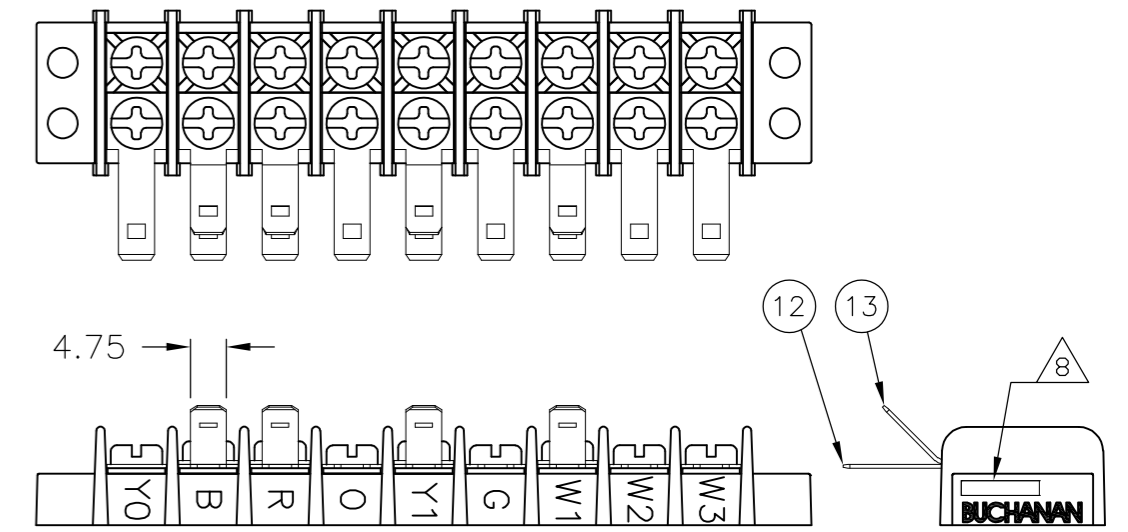
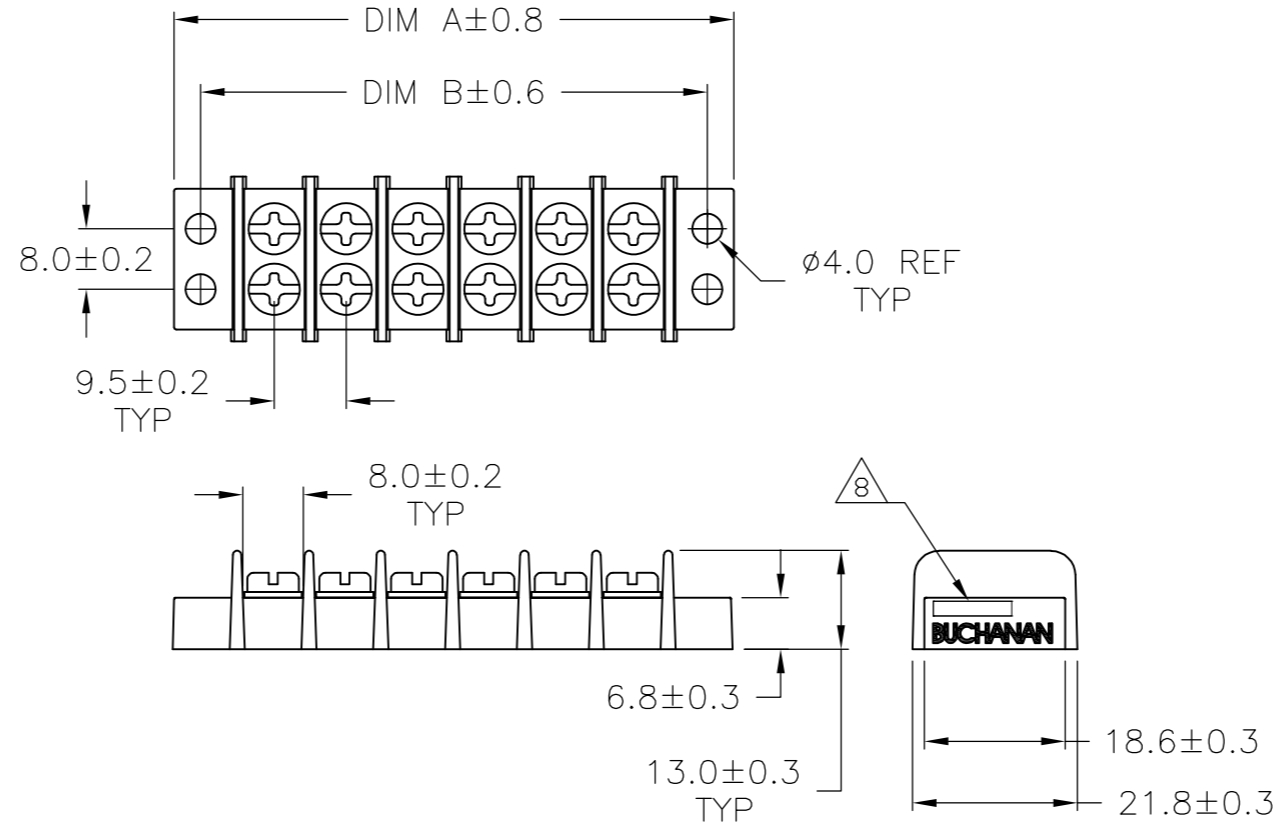
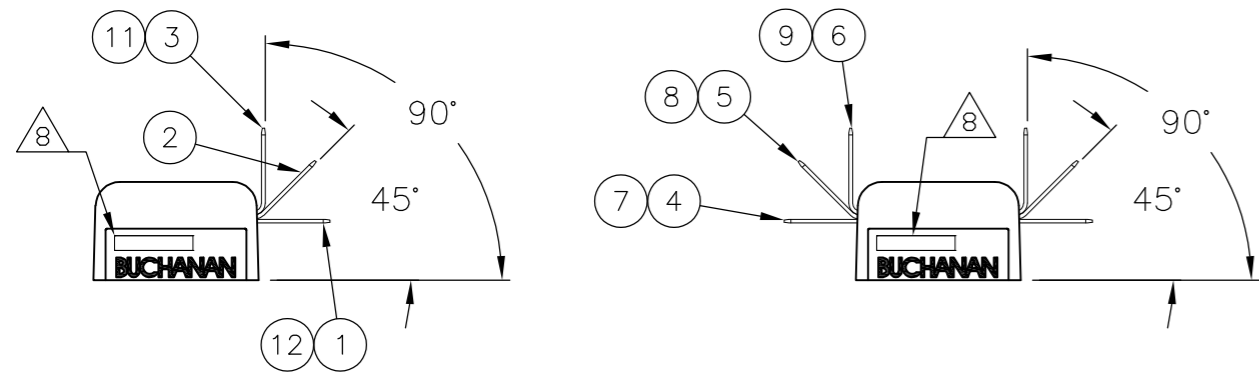

6-1546306-3

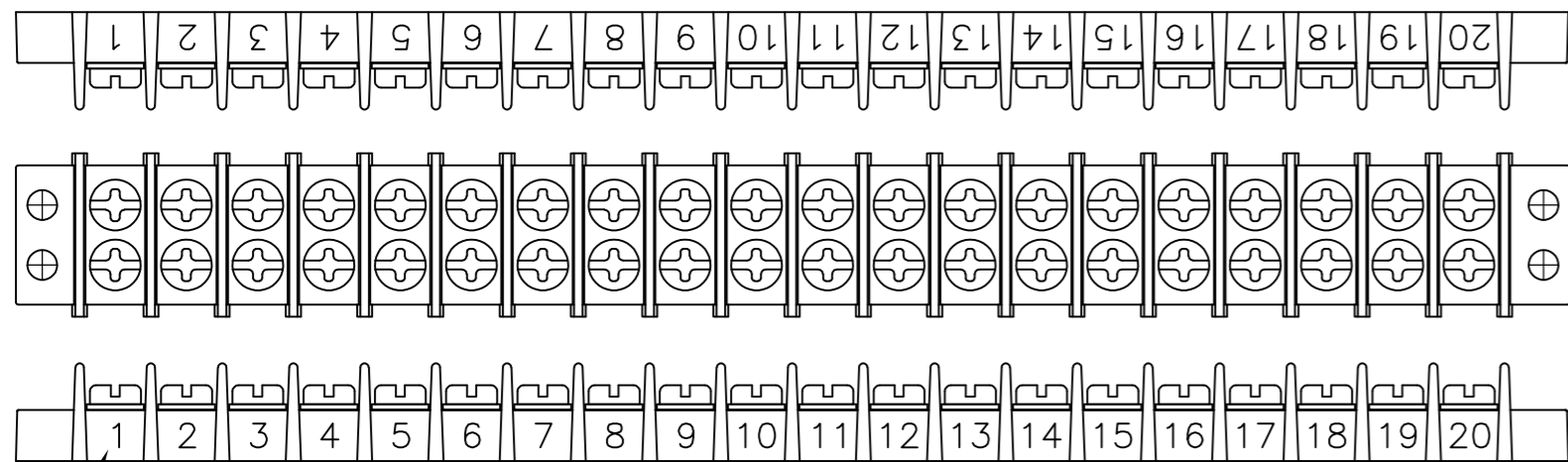

3-1546306-2

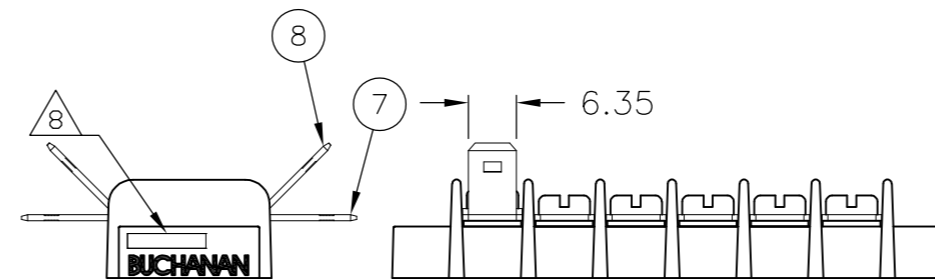

4-1546306-9

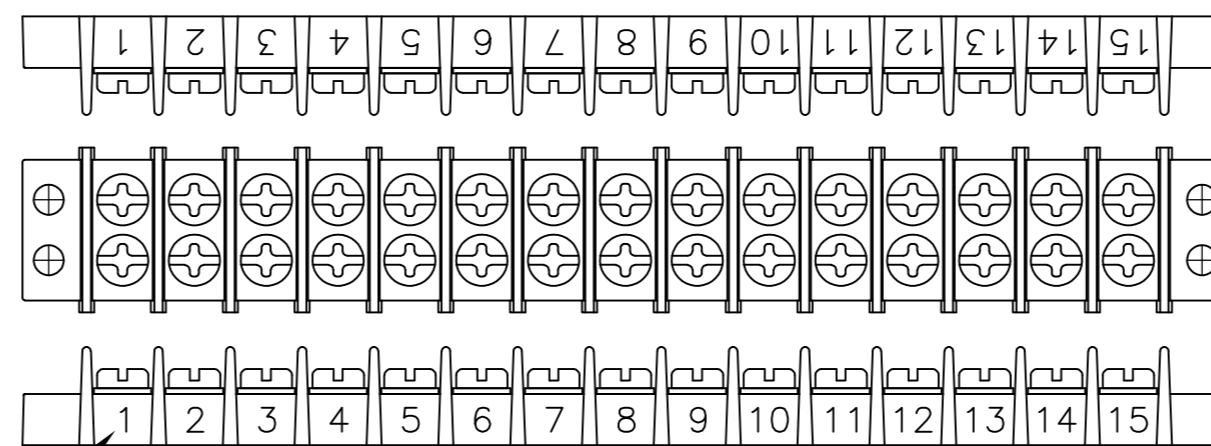

6-1546306-2

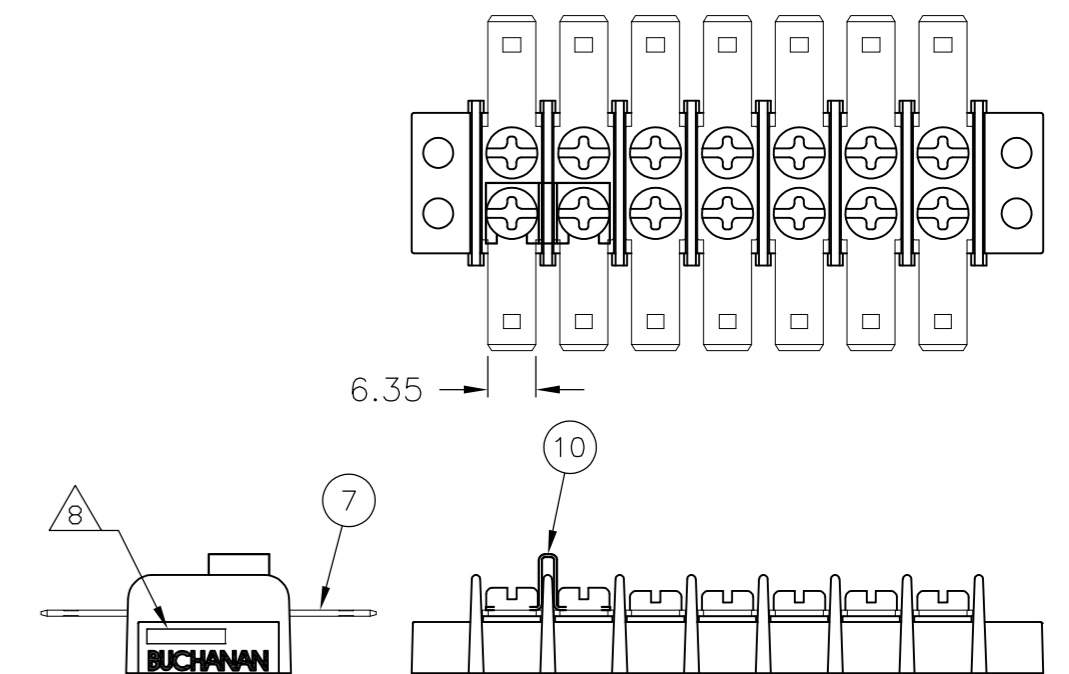

5-1546306-0

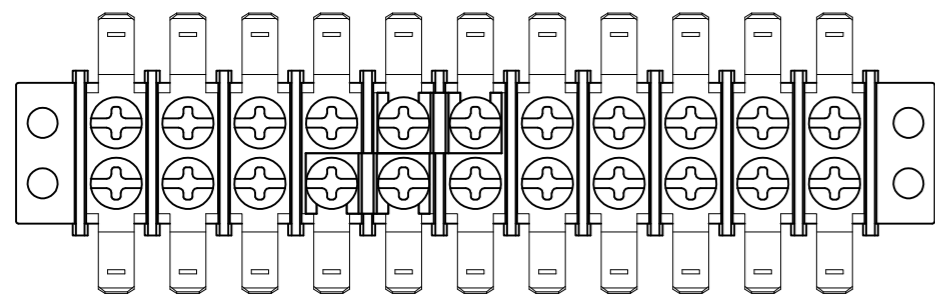

3-1546306-4

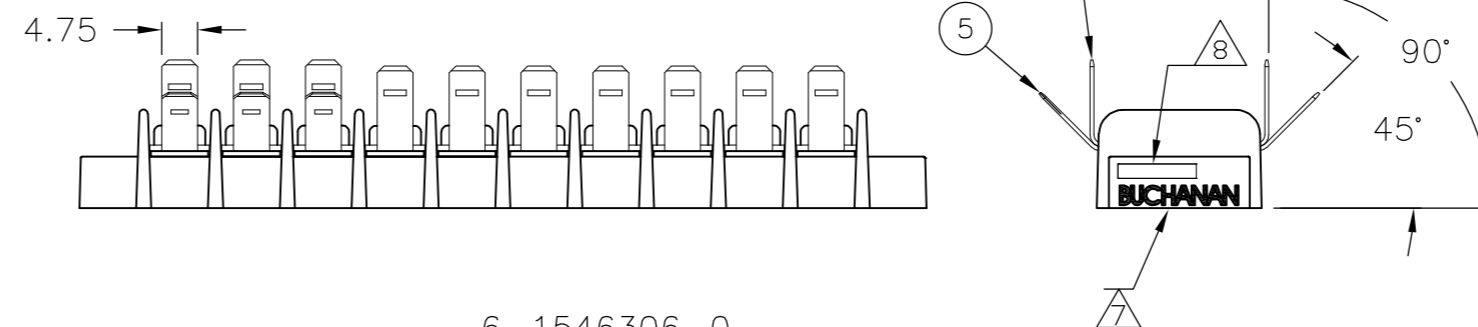
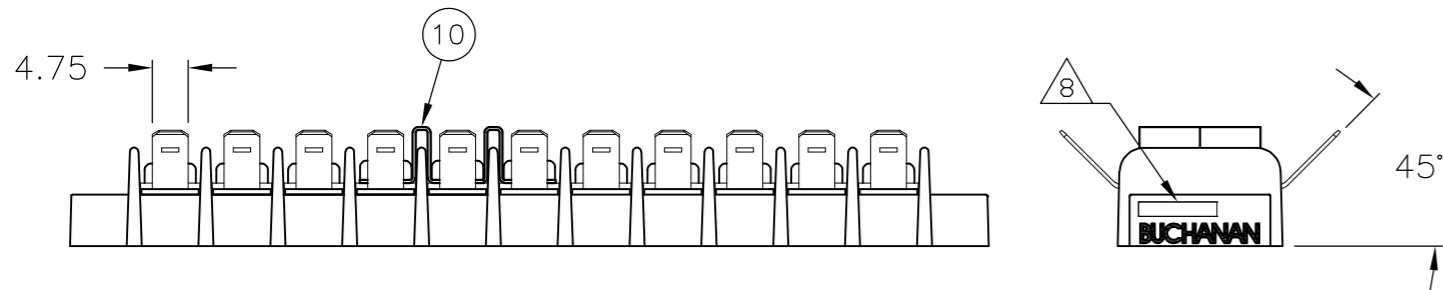

6-1546306-0

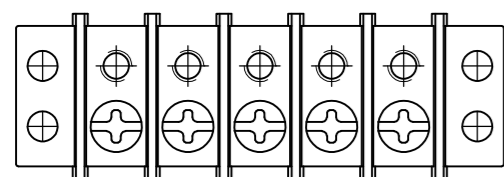

4-1546306-7

THIS DRAWING IS A CONTROLLED DOCUMENT.		DWN S SCHLEGEL 20AUG2002	TE Connectivity	
DIMENSIONS: MM		CHK C RICHARD 8/20/02		
TOLERANCES UNLESS OTHERWISE SPECIFIED:		APVD C RICHARD 8/20/02	NAME 9.50MM (.374) DBL ROW BARRIER STRIP W/O WASHER	
0 PLC ± -		PRODUCT SPEC	SIZE A2	
1 PLC ± 0.3		APPLICATION SPEC	CAGE CODE 00779	DRAWING NO C=1546306
2 PLC ± 0.25		WEIGHT	RESTRICTED TO	
3 PLC ± -		CUSTOMER DRAWING	SCALE NTS	SHEET 3 OF 3
4 PLC ± -			REV H2	
ANGLES ± 2°				
FINISH				