

Absolute maximum ratings

($T_a=25^\circ\text{C}$)

Symbol	Ratings	Unit
V_{CBO}	60±10	V
V_{CEO}	60±10	V
V_{EBO}	6	V
I_C	4	A
I_{CP}	8 (PW≤10ms, $D_u\leq 50\%$)	A
P_T	3 ($T_a=25^\circ\text{C}$)	W
	15 ($T_c=25^\circ\text{C}$)	
T_j	150	$^\circ\text{C}$
T_{stg}	-40 to +150	$^\circ\text{C}$

Electrical characteristics

($T_a=25^\circ\text{C}$)

Symbol	Specification			Unit	Conditions
	min	typ	max		
I_{CBO}			100	μA	$V_{CB}=50\text{V}$
I_{EBO}			10	mA	$V_{EB}=6\text{V}$
V_{CEO}	50	60	70	V	$I_C=10\text{mA}$
h_{FE}	1000				$V_{CE}=4\text{V}$, $I_C=3\text{A}$
$V_{CE(sat)}$			2.0	V	$I_C=3\text{A}$, $I_B=10\text{mA}$
t_{on}		1.0		μs	$V_{CC}\doteq 30\text{V}$, $I_C=3\text{A}$, $I_{B1}=-I_{B2}=10\text{mA}$
t_{stg}		4.0		μs	
t_f		1.5		μs	

Equivalent circuit diagram

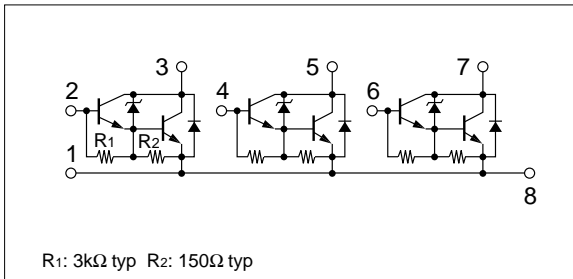

I_C - V_{CE} Characteristics (Typical)

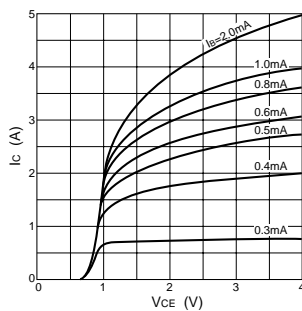

h_{FE} - I_C Characteristics (Typical)

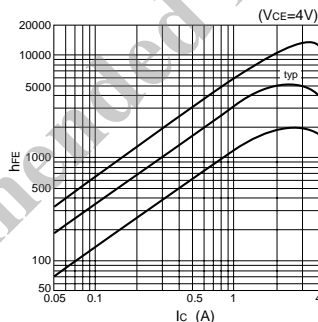

h_{FE} - I_C Temperature Characteristics (Typical)

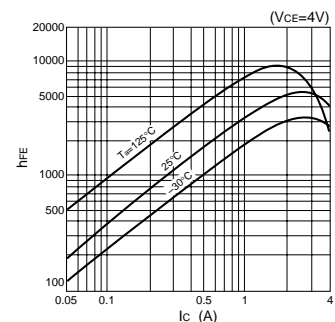

$V_{CE(sat)}$ - I_C Temperature Characteristics (Typical)

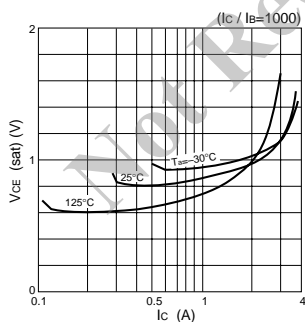

$V_{CE(sat)}$ - I_B Characteristics (Typical)

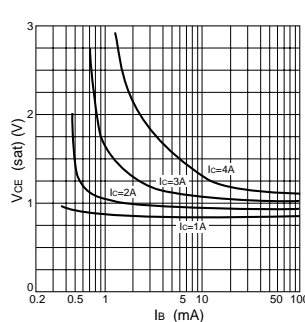

I_C - V_{BE} Temperature Characteristics (Typical)

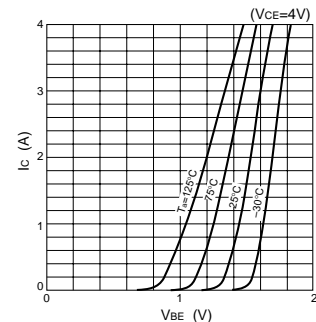

θ_{j-a} -PW Characteristics

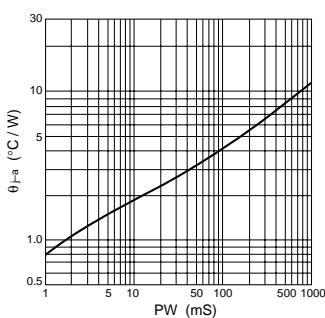

P_T - T_a Characteristics

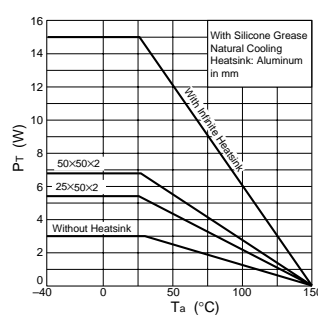

Safe Operating Area (SOA)

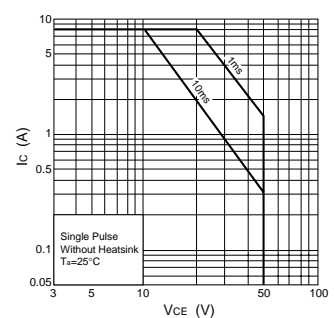

• SIP 8 (STA8Pin)

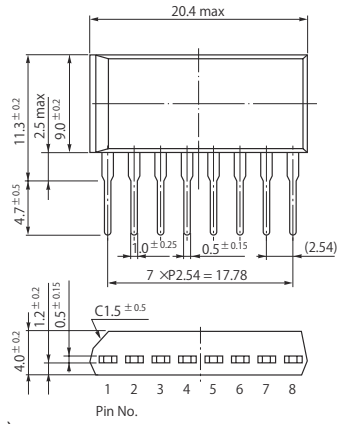

• SIP 10 (STA10Pin)

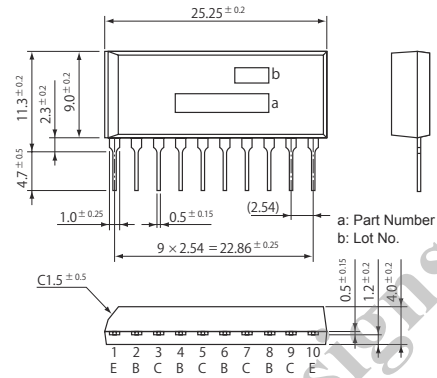

• SIP 12 (SMA12Pin)

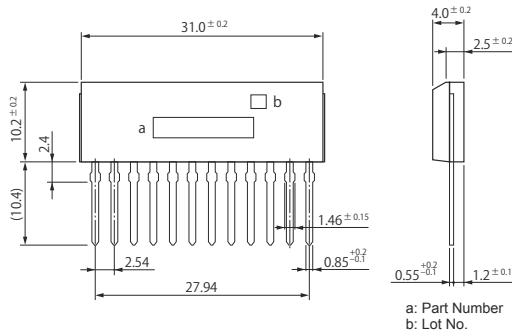

• SIP 15 (SMA15Pin)

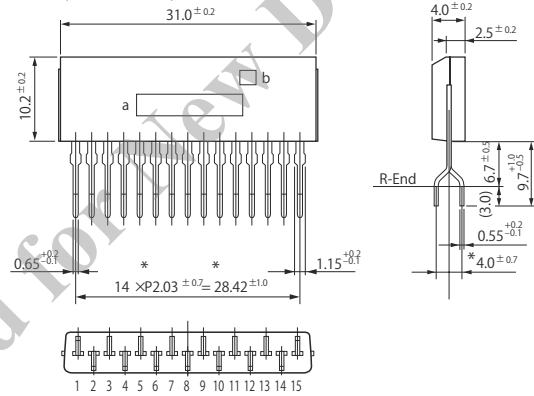

• SIP 12 with Fin (SLA12Pin)

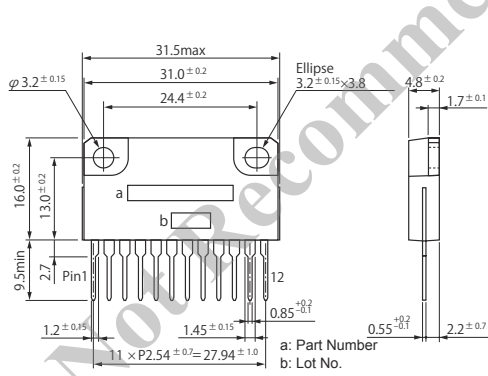

• SIP 15 with Fin (SLA15Pin)

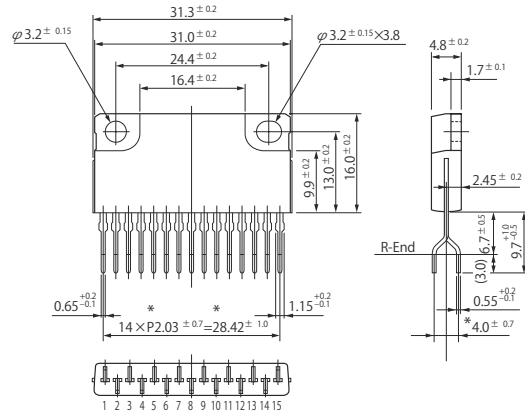

• SIP 21 with Fin (SLA21Pin)

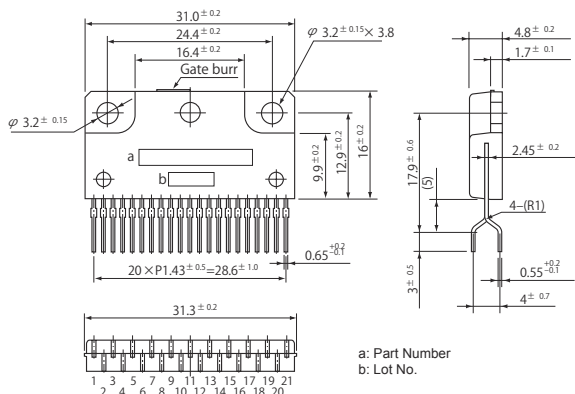

(Unit:mm)