

PART NUMBER	CKT SIZE
87635-1001	40

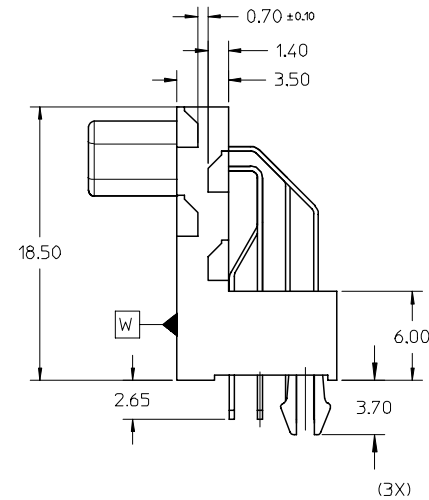
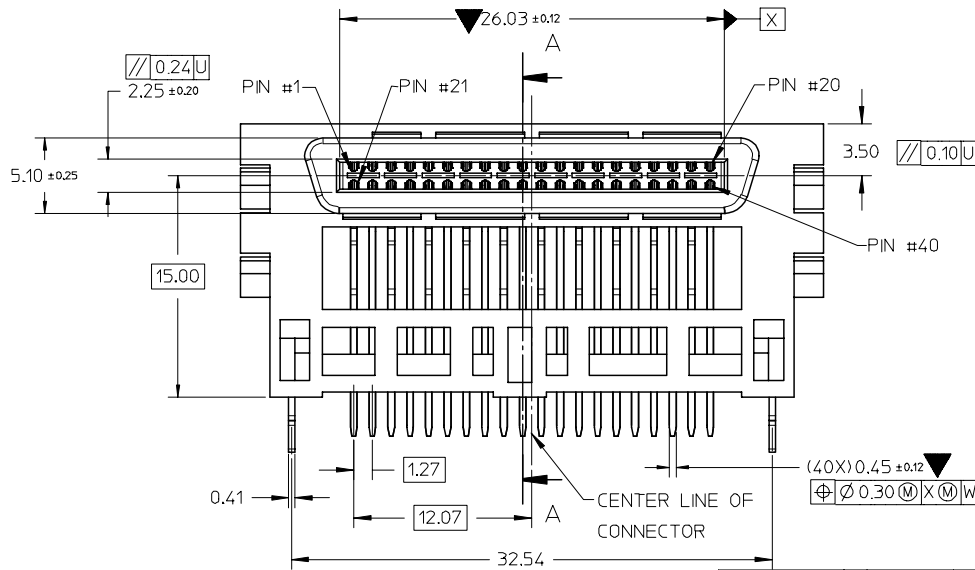
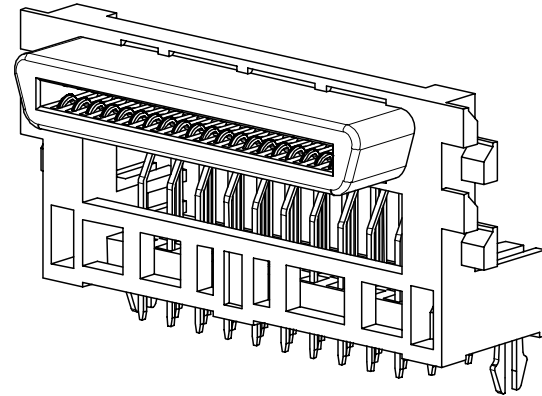
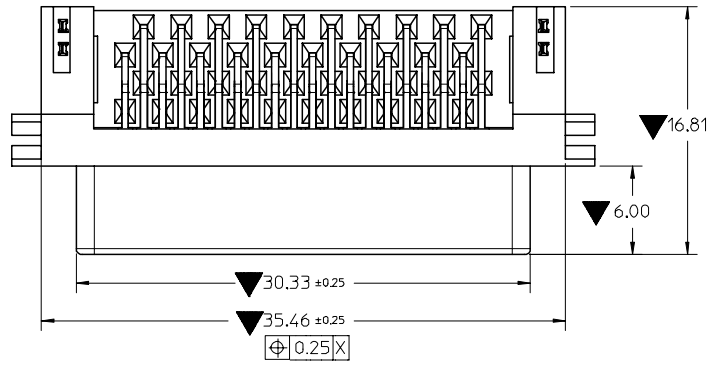

NOTES PLEASE SEE SHEET 2.

OBS	TIN/LEAD P/N
EC NO	S2006-0729
DRWN:MLONG	2006/02/27
CHKD:SHONG	2006/02/27
APPR:KCLING	2006/02/28
REV	DESCRIPTION

QUALITY SYMBOLS	▽=6
	▽=0

GENERAL TOLERANCES (UNLESS SPECIFIED)	
	mm
	INCH
4 PLACES	± ---
3 PLACES	± ---
2 PLACES	± 0.2
1 PLACE	± ---
ANGULAR ± 1 °	
DRAFT WHERE APPLICABLE MUST REMAIN WITHIN DIMENSIONS	

DIMENSION STYLE	
MM ONLY	
DRAWN BY	DATE
RSHAN	2000/09/28
CHECKED BY	DATE
SQUEK	2000/11/01
APPROVED BY	DATE
SKTOH	2000/11/02
MATERIAL NO.	
SEE TABLE	

SCALE	DESIGN UNITS	THIRD ANGLE PROJECTION	
NTS	METRIC		
TITLE			
LIO CONNECTOR, 40 CKTS			
R/A, T/H			
MOLEX INCORPORATED		SHEET NO.	
DOCUMENT NO.		1 OF 2	
SD-87635-001			
THIS DRAWING CONTAINS INFORMATION THAT IS PROPRIETARY TO MOLEX INCORPORATED AND SHOULD NOT BE USED WITHOUT WRITTEN PERMISSION			

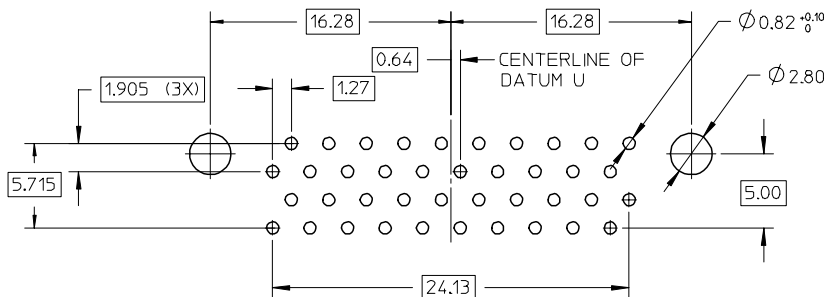
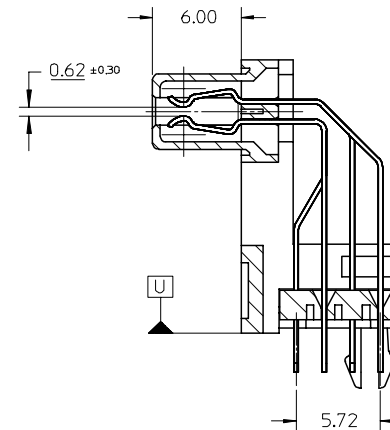
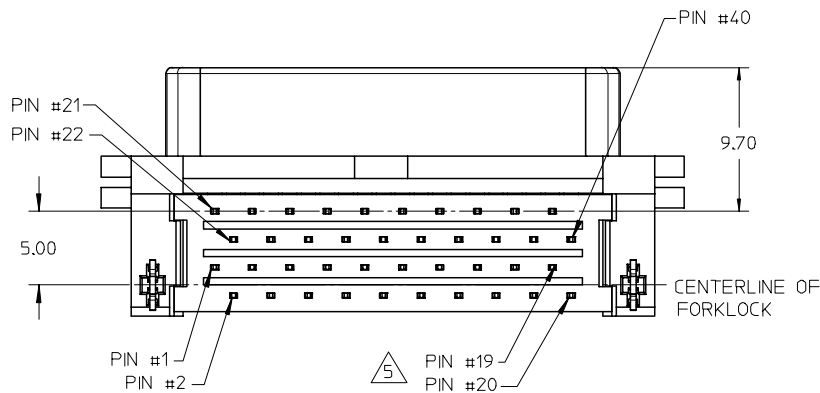

RECOMMENDED PCB LAYOUT  
(COMPONENT SIDE, THICKNESS 1.60)

SECTION A-A

NOTES:

- MATERIAL:  
HOUSING: THERMOPLASTIC, UL 94V-0, COLOR: MOLDED BLACK  
SPACER: THERMOPLASTIC, UL 94-0, COLOR: MOLDED BLACK  
CONTACT: COPPER ALLOY  
BOARDLOCK: COPPER ALLOY
  - FINISH:  
CONTACT : 1.27µm MIN. NICKEL UNDERPLATED OVERALL, TIN PLATED 100µin TO 200µin AT SOLDER TAIL AND GOLD PLATED 30µin AT CONTACT AREA  
BOARDLOCK: 0.76µm MIN. NICKEL UNDERPLATED OVERALL, TIN PLATED 100µin TO 200µin
  - HEIGHT OF GATE MARK SHOULD BE WITHIN 0.10MM
  - FLASH 0.10 MAX, PARTING LINE MISMATCH 0.1 MAX
- △ SOLDER TAIL POSITION SHALL BE CHECKED WITH GAUGE.

OBS TIN/LEAD P/N EC NO: S2006-0729 DRWN:MLONG CHKD:SHONG APPR:KCLING	2006/02/27 2006/02/27 2006/02/28	DESCRIPTION	QUALITY SYMBOLS	GENERAL TOLERANCES (UNLESS SPECIFIED)	DIMENSION STYLE	SCALE	DESIGN UNITS	THIRD ANGLE PROJECTION		
			▽=0 ∇=0	mm INCH	MM ONLY	NTS	METRIC	⊕ □		
				4 PLACES ± --- ± --- 3 PLACES ± --- ± --- 2 PLACES ± 0.2 ± --- 1 PLACE ± --- ± ---	DRAWN BY DATE RSHAN 2000/09/28	TITLE	LIO CONNECTOR, 40 CKTS R/A, T/H			
				ANGULAR ± 1 °	CHECKED BY DATE SQUEK 2000/11/01	APPROVED BY DATE SKTOH 2000/11/02				
		DRAFT WHERE APPLICABLE MUST REMAIN WITHIN DIMENSIONS		SEE TABLE	MATERIAL NO.	DOCUMENT NO.	SHEET NO.			
					SD-87635-001	2 OF 2				