

SFP-25GB-DW-C-15-I-EN-C

LG-Ericsson® Compatible TAA 10/25GBase-DWDM SFP28 Transceiver Dual-Rate 100GHz (SMF, Tunable, 15km, LC, DOM, -40 to 85C)

Features:

- SFF-8402 and SFF-8690 Compliant
- Duplex LC Connector
- 100GHz Channel Spacing
- Supports 9.8Gb/s to 25.78Gb/s
- Industrial Temperature -40 to 85 Celsius
- Single-mode Fiber
- Hot Pluggable
- Excellent ESD Protection
- Metal with Lower EMI
- RoHS Compliant and Lead Free



Applications:

- 25GBase
- Access, Metro and Enterprise

Product Description

This LG-Ericsson® SFP28 transceiver provides 10/25GBase-DWDM throughput up to 15km over single-mode fiber (SMF) using a tunable wavelength via an LC connector. It is guaranteed to be 100% compatible with the equivalent LG-Ericsson® transceiver. This easy to install, hot swappable transceiver has been programmed, uniquely serialized and data-traffic and application tested to ensure that it will initialize and perform identically. Digital optical monitoring (DOM) support is also present to allow access to real-time operating parameters. This transceiver is Trade Agreements Act (TAA) compliant. We stand behind the quality of our products and proudly offer a limited lifetime warranty.

ProLabs' transceivers are RoHS compliant and lead-free.

TAA refers to the Trade Agreements Act (19 U.S.C. & 2501-2581), which is intended to foster fair and open international trade. TAA requires that the U.S. Government may acquire only "U.S. – made or designated country end products."



Regulatory Compliance

- ESD to the Electrical PINs: compatible with MIL-STD-883E Method 3015.4.
- ESD to the LC Receptacle: compatible with IEC 61000-4-3.
- EMI/EMC: compatible with FCC Part 15 Subpart B Rules, EN55022:2010.
- Laser Eye Safety: compatible with FDA 21CFR, EN60950-1& EN (IEC) 60825-1, 2.
- RoHS: compliant with EU RoHS 2.0 directive 2015/863/EU.

DWDM Wavelength ITU Channels - 100 GHz Spacing

ITU Channel	Center Wavelength (nm)	Frequency (THz)	ITU Channel	Center Wavelength (nm)	Frequency (THz)
14	1566.31	191.4	38	1546.92	193.8
15	1565.50	191.5	39	1546.12	193.9
16	1564.68	191.6	40	1545.32	194.0
17	1563.86	191.7	41	1544.53	194.1
18	1563.05	191.8	42	1543.73	194.2
19	1562.23	191.9	43	1542.94	194.3
20	1561.42	192.0	44	1542.14	194.4
21	1560.61	192.1	45	1541.35	194.5
22	1559.79	192.2	46	1540.56	194.6
23	1558.98	192.3	47	1539.77	194.7
24	1558.17	192.4	48	1538.98	194.8
25	1557.36	192.5	49	1538.19	194.9
26	1556.55	192.6	50	1537.4	195.0
27	1555.75	192.7	51	1536.61	195.1
28	1554.94	192.8	52	1535.82	195.2
29	1554.13	192.9	53	1535.04	195.3
30	1553.33	193.0	54	1534.25	195.4
31	1552.52	193.1	55	1533.47	195.5
32	1551.72	193.2	56	1532.68	195.6
33	1550.92	193.3	57	1531.9	195.7
34	1550.12	193.4	58	1531.12	195.8
35	1549.32	193.5	59	1530.33	195.9
36	1548.51	193.6	60	1529.55	196.0
37	1547.72	193.7	61	1528.77	196.1

Absolute Maximum Ratings

Parameter	Symbol	Min.	Typ.	Max.	Unit	Notes
Maximum Supply Voltage	Vcc	0		4	V	
Storage Temperature	Tstg	-40		85	°C	
Operating Case Temperature	Tc	-40		85	°C	
Ambient Humidity	RH	5		95	%	w/o dew
Data Rate	DR ₂₅	24.3		25.78	Gbps	
	DR ₁₀	9.8	10.3	12.5	Gbps	
Receiver Damage Threshold	THd	3			dBm	

Electrical Characteristics

Parameter	Symbol	Min.	Typ.	Max.	Unit	Notes	
Power Supply Voltage	Vcc	+3.135	+3.3	+3.465	V		
Power Dissipation	P _{DISS}			2.5	W	1	
Power Supply Noise Tolerance	PSNT			66	mVp-p	2	
Transmitter							
Data Rate	DR ₂₅	24.3		25.78	Gbps	RS1 High Logic	
	DR ₁₀	9.8	10.3	12.5	Gbps	RS1 Low Logic	
Differential Input Voltage	VIN	190		700	mV	AC Coupled	
Differential Input Impedance	ZIN	90	100	110	Ω		
Tx_Disable	Input_Low	VIL	-0.3		0.8	V	3
	Input_High	VIH	2.0		Vcc+0.3	V	3
	Assert Time	tOFF			100	us	High
	Negate Time	tON			2.0	ms	Low
Tx_Disable to Start Reset	tReset	10			us	High	
Time to Initialize	tInit			90	s	4	
Tx_Fault	Output_Low	VFOL	-0.3		0.4	V	LVTTTL - Low is Normal
	Output_High	IFOH	-50		37.5	uA	
RS1 (Rate Select for Tx)	VIL	-0.3		0.8	V	Internally pulled down	
	VIH	2.0		Vcc+0.3	V		
Receiver							
Data Rate	DR ₂₅	24.3		25.78	Gbps	RS0 High Logic	
	DR ₁₀	9.8	10.3	12.5	Gbps	RS0 Low Logic	
Differential Output Voltage	VOUT	300		850	mV	AC Coupled	
Differential Output Impedance	ZOUT	90	100	110	Ω		

Rx_LOS (Loss of Signal)	Output_Low	V _{LOSL}	-0.3		0.4	V	LVTTL - Low is Normal
	Output_High	I _{LOSH}	-50		37.5	uA	
	Assert Time	t _{LOS-ON}			100	us	High@S
	De-Assert Time	t _{LOS-OFF}			100	us	Low@S
RS0 (Rate Select for Rx)		VIL	-0.3		0.8	V	Internally pulled down
		VIH	2		Vcc+0.3	V	

Notes:

1. Conditions: @3.3V and -40°C to 85°C.
2. From 10Hz to 10MHz.
3. LVTTL – “Low” at normal operation and “High” at shutdown (Poff).
4. Including reset of Tx_Fault.

Optical Characteristics

Parameter		Symbol	Min.	Typ.	Max.	Unit	Notes
Transmitter							
Average Launch Power		Pavg	-1.0		+3.0	dBm	
Optical Power Flatness		ΔPO	-1.0		+1.0	dB	All Channels
Transmitter Disabled Power		Poff			-30	dBm	@Tx_Disable is High
Optical Center Wavelength		λC	1528.77		1566.31	nm	1
Optical Center Frequency			191.40		196.10	THz	1
Center Wavelength Spacing			100			GHz	1
Wavelength Stability	Beginning of Life	λ _{p_BOL}	-1.7	λC	+1.7	GHz	2
	End of Life	λ _{p_EOL}	-2.5	λC	+2.5	GHz	2
Wavelength Tuning Speed		T _{TUNE}			30	ms	3
Spectral Width		σ			0.5	nm	@-20dB
Side-Mode Suppression Ratio		SMSR	30			dB	
Extinction Ratio		ER	8.0			dB	PRBS 2 ³¹ -1
Relative Intensity Noise		RIN _{20OMA}			-130.0	dB/Hz	
Optical Return Loss Tolerance		ORLT			20.0	dB	
Transmitter Reflectance					-26.0	dB	
Optical Eye Mask			IEEE 802.3cc 114.6 25GBASE- LR/ER {X1, X2, X3, Y1, Y2, Y3} = {0.31, 0.40, 0.45, 0.34, 0.38, 0.40}				Hit ratio 5E ⁻⁵

Receiver							
Optical Sensitivity	25.78Gbps or 24.33Gbps	S1			-19.0		4
	10.7Gbps, 10.3Gbps, 9.8Gbps	S2			-19.0		5
	11.3 - 11.1Gbps	S3			-19.0		6
Optical Overload			-4.0			dBm	7
Operating Wavelength		λ	1525		1575	nm	
Rx_LOS (Loss of Signal)	Assert	LOSA	-30.0			dBm	Rx Squelch Activated
	De-Assert	LOSD			-23.0	dBm	
	Hysteresis	LOSH	0.5		5.0	dB	
Return Loss of Receiver					-26.0	dB	
Auxiliary Management and Control Channel							
Bit Rate		BR _{AMCC}		1200		bps	
Modulation Depth		AMCC _{MD}	5		10	%	
Dynamic Range		DR _{AMCC}	-4		-24	dBm	8

Notes:

1. ITU-T 694.1 Grid Wavelength.
2. λ_C = ITU Grid Wavelength.
3. From any CH to any other CH. ASP Disable.
4. PRBS 2^{31} , BER 5×10^{-5} , Source ER=8.0dB, SMF 15km, G.652.
5. PRBS 2^{31} , BER 5×10^{-12} , Source ER=8.0dB, SMF 15km, G.652.
6. PRBS 2^{31} , BER 1×10^{-4} , Source ER=8.0dB, SMF 15km, G.652.
7. PRBS 2^{31} , Source ER=8.0dB.
8. AMCC_{MD} : 5%, 1200bps.

Pin Descriptions

Pin	Symbol	Name	Ref.
1	VeeT	Transmitter Ground.	1
2	Tx_Fault	Transmitter Fault Indication.	
3	Tx_Disable	Disables the transmitter or laser output.	2
4	SDA	2-Wire Serial Interface Data.	2
5	SCL	2-Wire Serial Interface Clock.	2
6	Mod_ABS	Indicates the module online state. This pin is connected to the VeeT or VeeR pin.	
7	RS0	Selects a rate for the module. This pin is connected to the 33kΩ resistor.	
8	LOS	Indicates a loss of received signals.	2
9	RS1	Selects a rate for the module. This pin is connected to the 33kΩ resistor.	
10	VeeR	Receiver Ground.	1
11	VeeR	Receiver Ground 1.	1
12	RD-	Inverse Received Data Output.	
13	RD+	Received Data Output.	
14	VeeR	Receiver Ground.	1
15	VccR	+3.3V Receiver Power.	1
16	VccT	+3.3V Transmitter Power.	1
17	VeeT	Transmitter Ground.	1
18	TD+	Transmit Data Input.	
19	TD-	Inverse Transmit Data Input.	
20	VeeT	Transmitter Ground.	1

Notes:

1. The ground of the module (operating module ground) and that of the module shell are separate from each other.
2. 4.7kΩ–10kΩ resistor is used on the module to pull the output up to 3.15–3.45V.

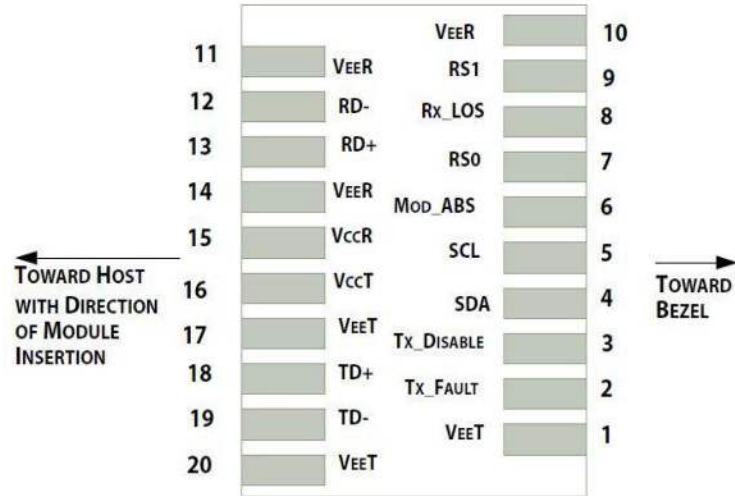

Pin-Out of Connector Block on the Host Board

Recommended Circuit Schematic

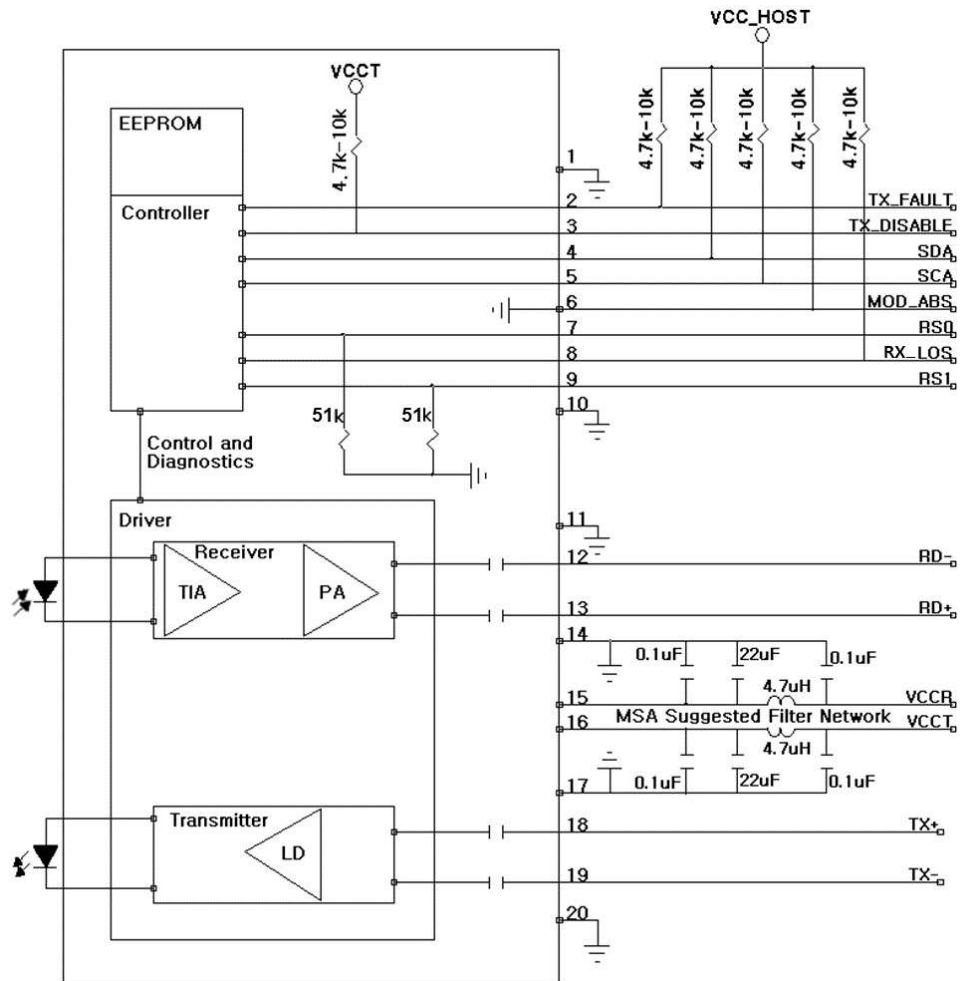

Mechanical Specifications

Small Form Factor Pluggable (SFP) transceivers are compatible with the dimensions defined by the SFP Multi-Sourcing Agreement (MSA).

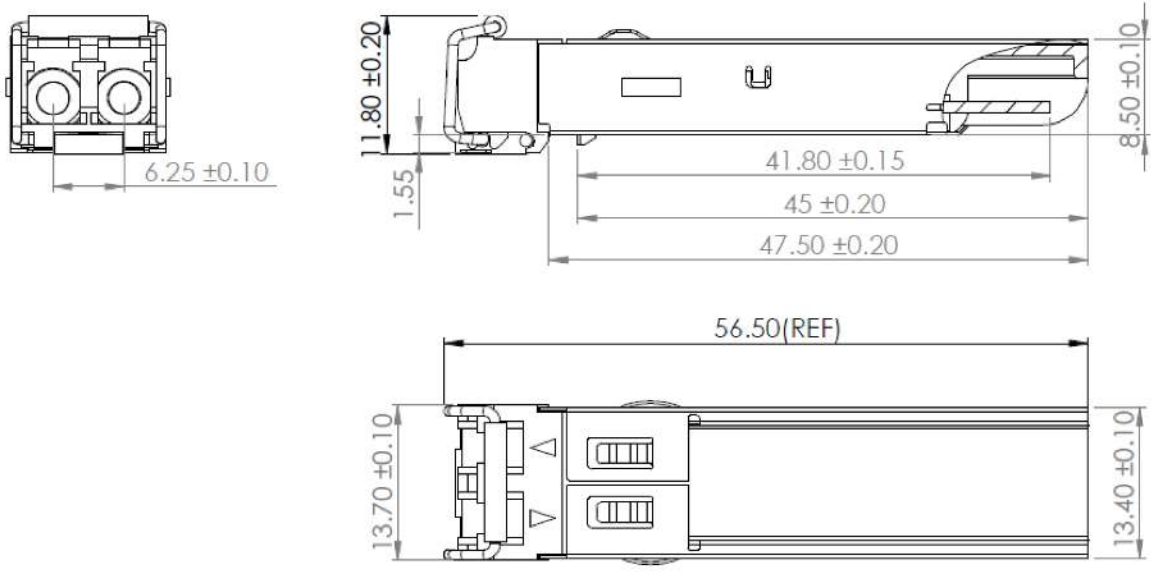

EEPROM Information

EEPROM memory map-specific data field description is as below:

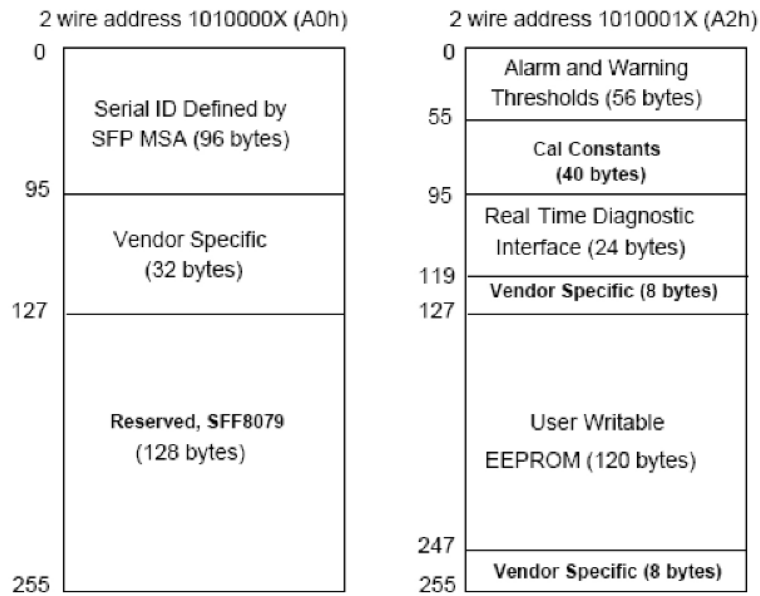

About ProLabs

Our experience comes as standard; for over 15 years ProLabs has delivered optical connectivity solutions that give our customers freedom and choice through our ability to provide seamless interoperability. At the heart of our company is the ability to provide state-of-the-art optical transport and connectivity solutions that are compatible with over 90 optical switching and transport platforms.

Complete Portfolio of Network Solutions

ProLabs is focused on innovations in optical transport and connectivity. The combination of our knowledge of optics and networking equipment enables ProLabs to be your single source for optical transport and connectivity solutions from 100Mb to 400G while providing innovative solutions that increase network efficiency. We provide the optical connectivity expertise that is compatible with and enhances your switching and transport equipment.

Trusted Partner

Customer service is our number one value. ProLabs has invested in people, labs and manufacturing capacity to ensure that you get immediate answers to your questions and compatible product when needed. With Engineering and Manufacturing offices in the U.K. and U.S. augmented by field offices throughout the U.S., U.K. and Asia, ProLabs is able to be our customers best advocate 24 hours a day.

Contact Information

ProLabs US

Email: sales@prolabs.com

Telephone: 952-852-0252

ProLabs UK

Email: salessupport@prolabs.com

Telephone: +44 1285 719 600