

Optional super bright LEDs



Optional Green LED Display

3 1/2 DIGIT with 0.56" LEDs in a NEMA type 1 Style Case

UM-35-DCA

20/50/100/200mV DC Full Scale Meter

Measuring DC signals as low as 20mV full scale, this meter is ideal for high DC current measurement using low voltage drop current shunts, or for other precision low DC mV measurements.

General Features

The UM-35-DCA is an cost-effective, low DC voltage measuring meter with four header selectable full scale ranges of 20mV, 50mV, 100mV and 200mV which facilitate scaling in engineering units. The meter is particularly suited for measuring DC current using 50mV standard current shunts.

Typical Application Connections

DC Current measurement using a 50mV Shunt.
Easily user scaled to display currents up to 1999 Amps.

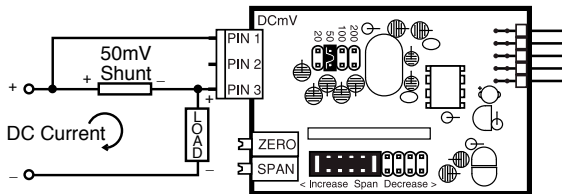

Shunt may be in Hi or Lo side of Load.

DC mV measurement with a resolution of 100 microVolts.
Easily user scaled to display voltages up to 199.9 mV.

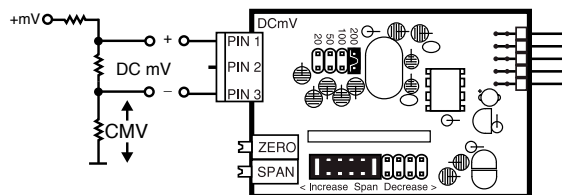

Can be used to measure single-ended or differential inputs.
Max CMV (common mode voltage) is 50V*.
Because CMV is common with meter ground, higher CMV inputs to a max of 1KV require mechanical isolation of all contactable meter parts.

Specifications

- Input Configuration:**.....Single-ended, however isolated power supply enables differential measurements up to a maximum common mode of 50V.*
A Zero Potentiometer is provided that can offset the displayed reading ± 500 counts.
- Full Scale Ranges:**Four header selectable ranges of ± 20 mV DC, ± 50 mV DC, ± 100 mV DC & ± 200 mV DC full scale
- Input Impedance:**.....50K Ω /100K Ω /65K Ω in 50/100/200 ranges
- A/D Converter:**12 Bit Dual Slope
- Accuracy:** $\pm(0.05\%$ of reading + 2 counts)
- Temperature Coefficient:** 100 ppm/ $^{\circ}$ C (Typical)
- Warm Up Time:**2 minutes to specified accuracy
- Conversion Rate:**.....3 conversions per second (Typical)
- Display:**.....3 1/2 digit 0.56" Red LED display (std), Green or Super Bright Red are optional.
Range -1999 to 1999 counts.
- Decimal Selection:**Header under face plate, X•X•X•X•
- Over-range Indication:**....1 (MSD) displayed all other digits blank
- Power Supply (PS6 std):**..Auto-sensing 85-305VAC or 120-430VDC, 50/60Hz App. 1W
(PS7 opt.) .Isolated (1.5kV) auto-sensing 9-36 VDC 1W
(PS11 opt.)..Isolated (1.5kV) auto-sensing 36-75 VDC 1W
(PS8 opt.)....5VDC/200mA
- Operating Temperature:**...-10 to 50 $^{\circ}$ C
- Storage Temperature:**-20 to 70 $^{\circ}$ C.
- Relative Humidity:**95% (non-condensing)
- Case Dimensions:**Bezel 3.78"Wx1.89"H (96mm x 48mm)
Depth behind bezel 3.36" (83.5mm) Plus 0.5 to .9" (12.7 to 22.8mm) depending on connector used.
- Weight:**NW. 12oz (0.34kg)
15.6oz (0.44kg). when packed.

UM-Series utility meters for switchboard and process indication

- UM-35-ACA**AC amps, True RMS, (1 or 5 Amp internal shunt), 3.5 digit.
- UM-35-ACV**AC volts, True RMS. 199.9V AC/700V AC header selectable ranges, 3.5 digit.
- UM-35-DCA**DC mV ± 20 mV/ ± 50 mV/ ± 100 mV/ ± 200 mV header selectable ranges, 3.5 digit
- UM-35-DCV**DC Volts ± 2 V/ ± 20 V/ ± 200 V DC header selectable ranges, 3.5 digit.
- UM-40-ACV**AC volts, True RMS. 199.9V AC/700V AC header selectable ranges,4.0 digit.
- UM-45-DCA**DC mV ± 20 mV/ ± 50 mV/ ± 100 mV/ ± 200 mV header selectable ranges, 4.5 digit
- UM-45-DCV**DC Volts ± 2 V/ ± 20 V/ ± 200 V DC Header selectable ranges, 4.5 digit.

- UM-35-CL**Process 4 to 20mA (100.0), easily user scalable in engineering units from -1999 to +1999. 3.5 digit
- UM-35-HZ**15Hz to 199.9Hz or optional 40Hz to 400Hz up to 500V AC , 3.5 digit.
- UM-35-SG**Pressure, strain gage and load cell, 4 and 6 wire, 5V DC excitation, Header Selectable Sensitivity 2mV/V, 5mV/V, 10mV/V, 20mV/V. 3.5 digit
- UM-35-JF**J thermocouple input, 1 $^{\circ}$ resolution, order $^{\circ}$ C or $^{\circ}$ F, 3.5 digit
- UM-35-KF**K thermocouple input, 1 $^{\circ}$ resolution, order $^{\circ}$ C or $^{\circ}$ F, 3.5 digit
- UM-35-RTD**100 Ω platinum RTD, 3 or 4 wire, order $^{\circ}$ C or $^{\circ}$ F and 0.1 $^{\circ}$ or 1 $^{\circ}$, 3.5 digit
- UM-45-CL**Process 4 to 20mA (100.0), easily user scalable in engineering units from -19999 to +19999. 4.5 digit

Calibration Procedure

1. Select the required full scale voltage range, by repositioning the jumper clip on the range select header.
2. Apply an input of 0 millivolts. Adjust the zero offset pot until the meter reads 000.
4. Apply a known high input signal that is within the full scale voltage range selected.
5. Adjust the Span Pot until the meter displays the required reading for the signal being applied.
6. The UM-35-DCA is now calibrated and ready for use.
(Whenever a new range is selected, re-calibration is required to meet the specified accuracy).

Decimal Point Selection

Decimal selection is made by moving the jumper to the indicated position on the header for the decimal required on the front of the display board.

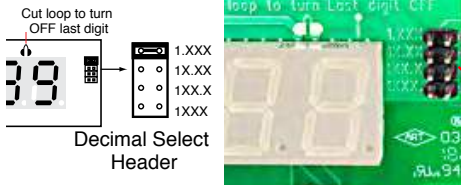

To open meter, insert a flat head screwdriver or similar instrument in both slots on the side of the cover and pry open. The UM-Series meters slide out from the front of the case as a complete assembly.

Signal Conditioning Components

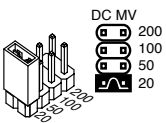

INPUT RANGE Header

Range values are marked on the PCB. After selecting a new range with the single jumper clip, recalibration is required.

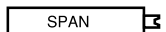

SPAN Potentiometer (Pot)

To the Right Front
Turn Clockwise to Increase Reading

The 15 turn SPAN pot is always on the right side (as viewed from the front of the meter). Typical adjustment is 100% of the input signal range.

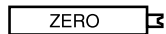

ZERO Potentiometer (Pot)

To the Left Front
Turn Clockwise to Increase Reading

The Optional ZERO pot when installed is always to the left of the SPAN pot (as viewed from the front of the meter). Typically it enables the displayed reading to be offset ± 100 counts.

Optional Face Plate Descriptors

AC	V	1V	KVAR	1000	Hz	RPM
V	mV	100V	PF	%	C	Case
DC	1000V	1A	PSIG	mS	1000	100
KW	W	KWH	pH	%	K	RPS
A	1000A	mA	NMM	KA	RPS	1000
mWs	µm	KWs	l	1/sep	ml	cm
DRP	mm/s	1/min	mm	1/sep	1/s	cm
100	1000	10000	10000	10000	100	dB

To customize the face plate, clear adhesive label containing various popular descriptors may be ordered. Choose the descriptor desired, peel off the adhesive backing and align the descriptor in the center right of the faceplate.

P.N.: 75-DESCRIPTR

Component Layout

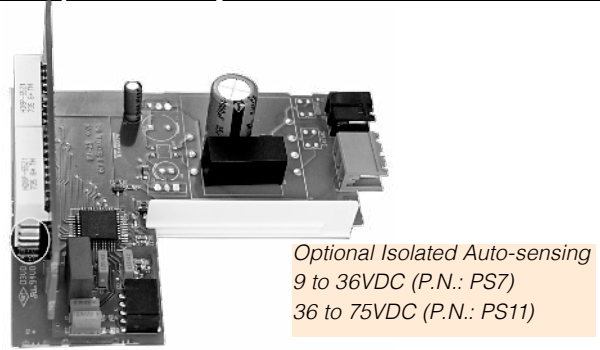

Optional Isolated Auto-sensing
9 to 36VDC (P.N.: PS7)
36 to 75VDC (P.N.: PS11)

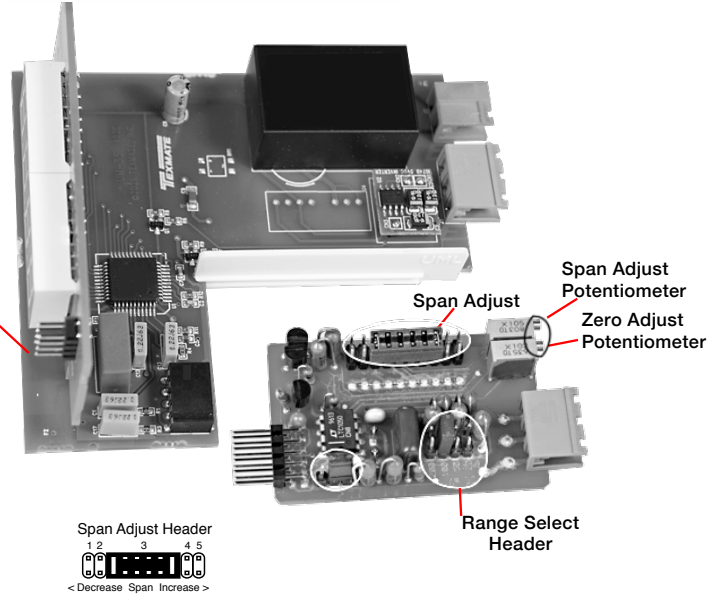

SPAN Adjust Header position	1	2	3	4	5
SPAN Pot %	10%	10%	10%	10%	10%
Signal Span %	20%	40%	60%	80%	100%

Connector Pinouts

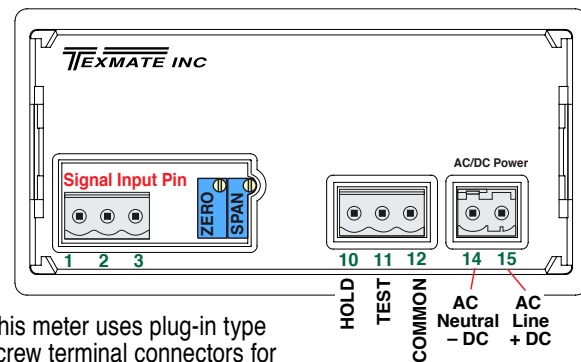

This meter uses plug-in type screw terminal connectors for all connections.

Connectors

This meter uses plug-in type screw terminal connectors for all input and output connections. The power supply connections (pins 14 and 15) have a unique plug and socket outline to prevent cross connection. The main board uses standard right-angled connectors.

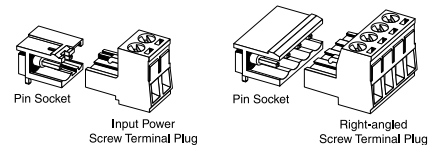

WARNING: AC and DC input signals and power supply voltages can be hazardous. Do Not connect live wires to screw terminal plugs, and do not insert, remove or handle screw terminal plugs with live wires connected.

UM Case Dimensions and Panel Cutouts

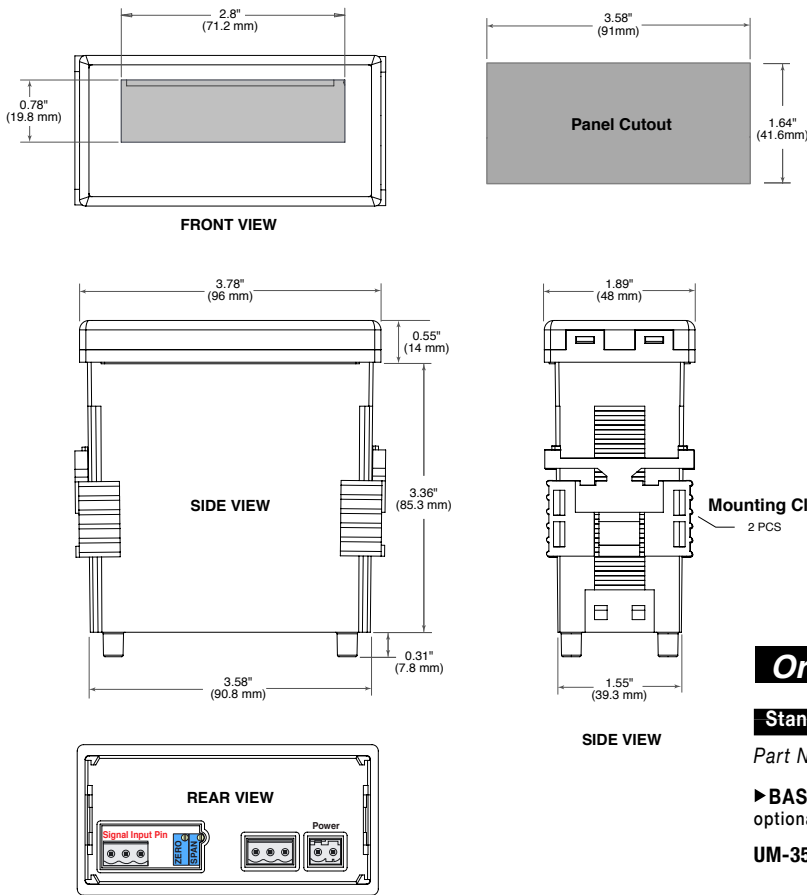

Clear Lockable Water-proof Cover

The clear lockable cover is designed to be dust and waterproof to NEMA-4X, IP65 standards. The assembly consists of a base and a cover with a cam hinge and key-lock fastening mechanism. An O-ring, or neoprene gasket forms a seal between the base and the panel. The cam hinge prevents the cover from closing when opened until pushed closed. The cover has a tapered recess that, when closed, forms a seal with a tapered spigot on the base. A key-lock employs a cam locking device to force the spigot into the recess, ensuring seal integrity. A safety catch keeps the cover closed even when the key is removed, preventing unauthorized opening.

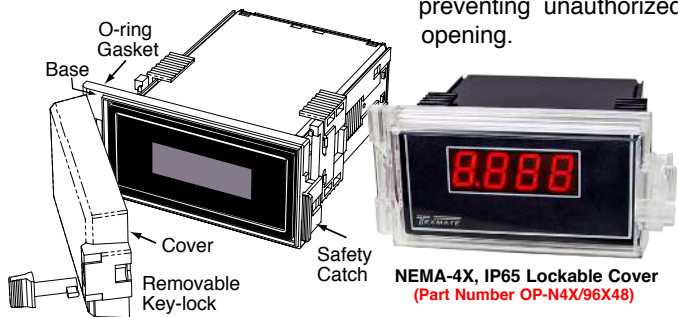

1934 Kellogg Ave., Carlsbad, CA 92008
Tel: 1-760-598-9899 • 1-800-TEXMATE • Email: orders@texmate.com

Warranty and User's Responsibility

WARRANTY

Texmate warrants that its products are free from defects in material and workmanship under normal use and service for a period of one year from date of shipment. Texmate's obligations under this warranty are limited to replacement or repair, at its option, at its factory, of any of the products which shall, within the applicable period after shipment, be returned to Texmate's facility, transportation charges pre-paid, and which are, after examination, disclosed to the satisfaction of Texmate to be thus defective. The warranty shall not apply to any equipment which shall have been repaired or altered, except by Texmate, or which shall have been subjected to misuse, negligence, or accident. In no case shall Texmate's liability exceed the original purchase price. The aforementioned provisions do not extend the original warranty period of any product which has been either repaired or replaced by Texmate.

USER'S RESPONSIBILITY

We are pleased to offer suggestions on the use of our various products either by way of printed matter or through direct contact with our sales/application engineering staff. However, since we have no control over the use of our products once they are shipped, NO WARRANTY WHETHER OF MERCHANTABILITY, FITNESS FOR PURPOSE, OR OTHERWISE is made beyond the repair, replacement, or refund of purchase price at the sole discretion of Texmate. Users shall determine the suitability of the product for the intended application before using, and the users assume all risk and liability whatsoever in connection therewith, regardless of any of our suggestions or statements as to application or construction. In no event shall Texmate's liability, in law or otherwise, be in excess of the purchase price of the product.

Texmate cannot assume responsibility for any circuitry described. No circuit patent or software licenses are implied. Texmate reserves the right to change circuitry, operating software, specifications, and prices without notice at any time.

Ordering Information

Standard Options for this Model Number

Part Number Description

► **BASIC MODEL NUMBER** standard display and standard power supply unless optional versions are ordered.

UM-35-DCA..... DPM, DC mV ± 20 mV, ± 50 mV, ± 100 mV, ± 200 mV
Header selectable ranges (ID02)

► DISPLAY

DR0.56" Red LEDs

UM-BRIGHT.....Super bright Red LEDs, 0.56 inch high

UM-GREEN.....Green LEDs, 0.56 inch high

► POWER SUPPLY

PS6 (Std.).....85-305VAC or 120-430VDC, 50/60Hz, Approx.1W . . .

PS7.....Isolated (1.5kV) 9-36VDC Approx.1W

PS11.....Isolated (1.5kV) 36-75VDC Approx.1W

PS8......5 VDC /200mA

Special Options and Accessories

Part Number Description

► SPECIAL OPTIONS (Specify Inputs & Req. Reading)

ZR.....Input Range Change to another Standard Range

ZRS-SMUM.....Non-standard range change and/or Scale change

► ACCESSORIES

OP-N4X/96X48.96x48mm clear lockable front cover NEMA 4X, splash proof

CASE.RPUM. . .Case: Replacement with Accessories

ART-NRC-DEC.NRC for Artwork & set-up Custom Faceplate and/or Descriptor

ART-FS1Produce & Install Custom Faceplate per meter - 1 color no-min

ART-FS2Produce & Install Custom Faceplate per meter - 2 color no-min

ART-FS3Produce & Install Custom Faceplate per meter - 3 color no-min

75-DESCRIPTR Clear adhesive descriptors label for face plate

Custom Face Plates

Texmate Produces Thousands of Custom OEM Face Plates. Have Texmate Design and produce a Custom Face Plate for your next project!

• Custom face plates have a non-recurring artwork charge. A serial number is then assigned to each artwork to facilitate reordering.

UM-35-DCA Technical Manual Copyright © 2022 Texmate Inc. All rights reserved. Published by: Texmate Inc. USA. Information in this Technical Manual is subject to change without notice due to correction or enhancement. The information described in this manual is proprietary to Texmate, Inc. and may not be copied, reproduced or transmitted, in whole or in part, in connection with the design, manufacture, or sale of apparatus, device or private label product without the express written consent of Texmate, Inc.