

Panasonic

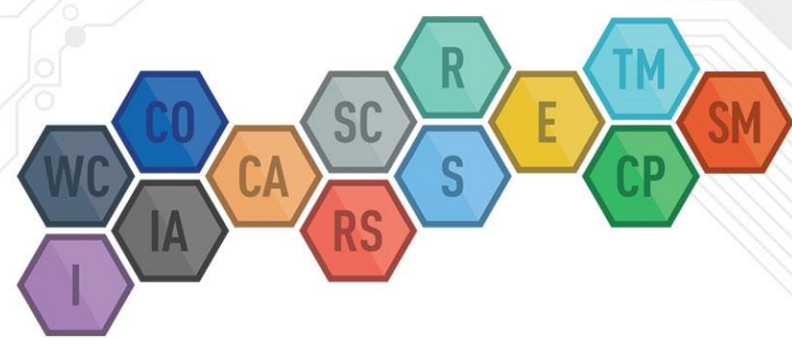

PAN1760A & PAN1762

Product Highlights

BLE Market Comparison

development

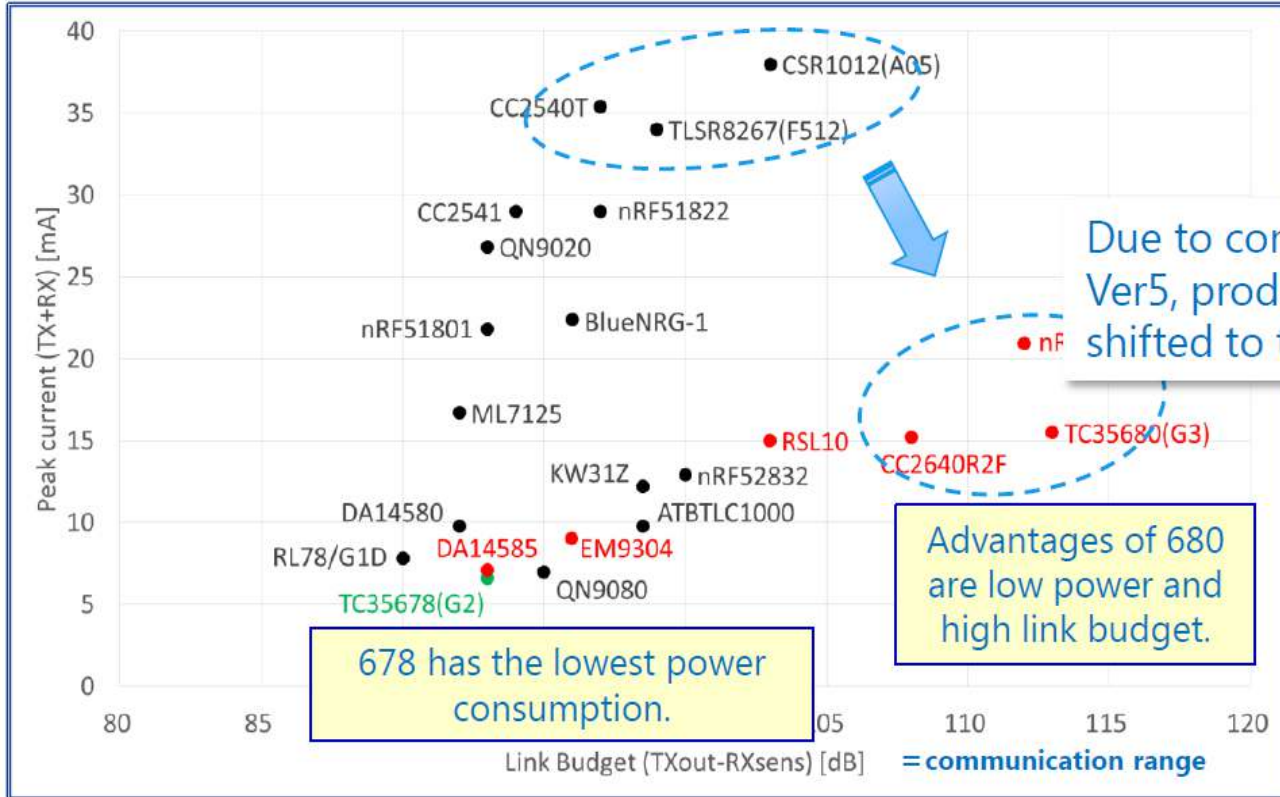

PAN1760A is based on Toshiba TC35678

PAN1762 is based on Toshiba TC35680



PAN1760A (BLE 4.2)

Best in Class Power Consumption



- Toshiba TC35678
- MESH 1.0 (BT SIG Approved)
- Bluetooth® Core spec V4.2
- AT Commands



-
- Ultra Low Power
 - Peak current 3.6mA (TX 0dBm@3.0V)
 - Sleep current < 1.2uA (Advertise)
 - Interfaces
 - UART/SPI/I²C/GPIOs
 - User Memory:
 - 80 kByte SRAM
 - 256 kByte Flash

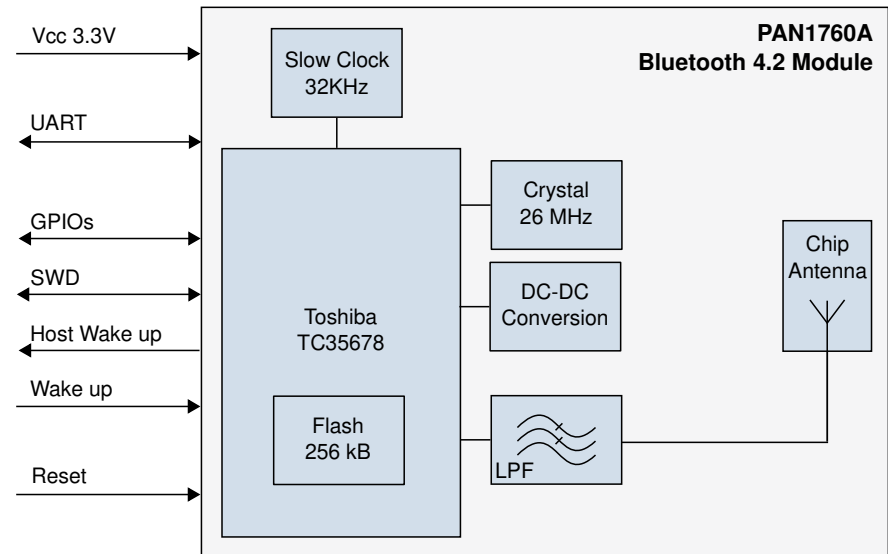

PAN1762 (BLE 5.0)

- Toshiba TC35680
 - Bluetooth® Core spec V5.0 (high speed & long range)
-
- 15.6 mm x 8.7 mm x 1.9 mm
 - Host mode, AT command mode or stand-alone operation mode
 - 18 General Purpose IOs
 - 2·SPI, 2·I²C, UART, PWM, Wake-up inputs, general purpose ADC
 - ARM® Cortex®-M0
 - 128 kB flash memory
 - 128 kB internal RAM for application code and data patches

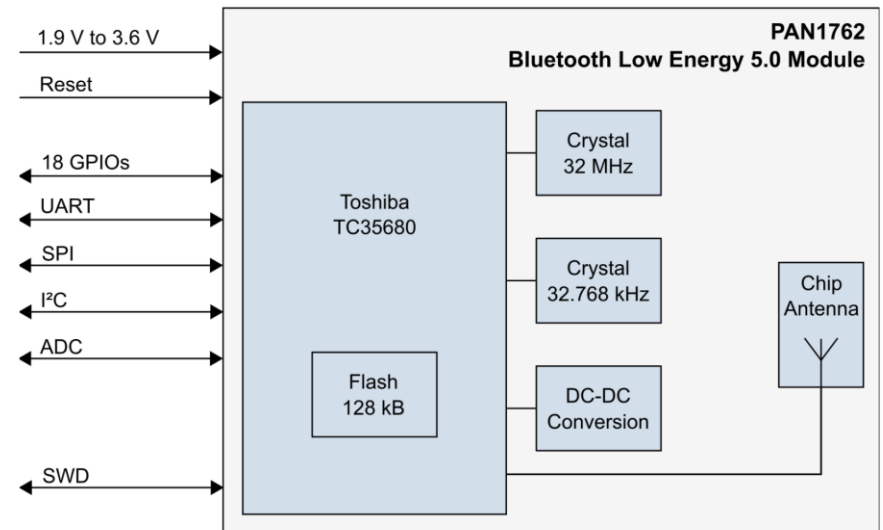

Product Comparison

Bluetooth® LE Product Comparison

Item	TC35678FSG	TC3567CFSG	TC35680FSG
Bluetooth Core spec	V4.2	V4.2	V5.0
CPU core	Cortex-M0	Cortex-M0	Cortex-M0
Peak current Tx @ 0dBm	3.3mA	3.3mA	6.0mA
Peak current Rx	3.3mA	3.3mA	5.1mA
Tx Output Power (Max)	0dBm	0dBm	+8dBm
Rx Sensitivity	-93.5dBm	-93.5dBm	-95dBm (1Mbps) -105dBm (125kbps)
Standalone	✓	✓	✓
Scatter net	✓	✓	NA
LE secure connection	✓	✓	✓
Maximum # of Connections	8 (2 masters/8 slaves)	4 (2 masters/4 slaves)	1 (1 master/1 slave)
User NVM area	256KB	128KB	128KB
User RAM area	83KB	51KB	76KB
Input Main Clock Frequency	26MHz	26MHz	32MHz
PKG	QFN40 5.0x5.0mm	QFN40 5.0x5.0mm	QFN40 5.0x5.0mm
Operation Temperature	-40 / +85 °C	-40 / +85 °C	-40 / +85 °C



Toshiba TC35680 Range Testing

Distance Measurement of TC35680

600m communication distance has been demonstrated.

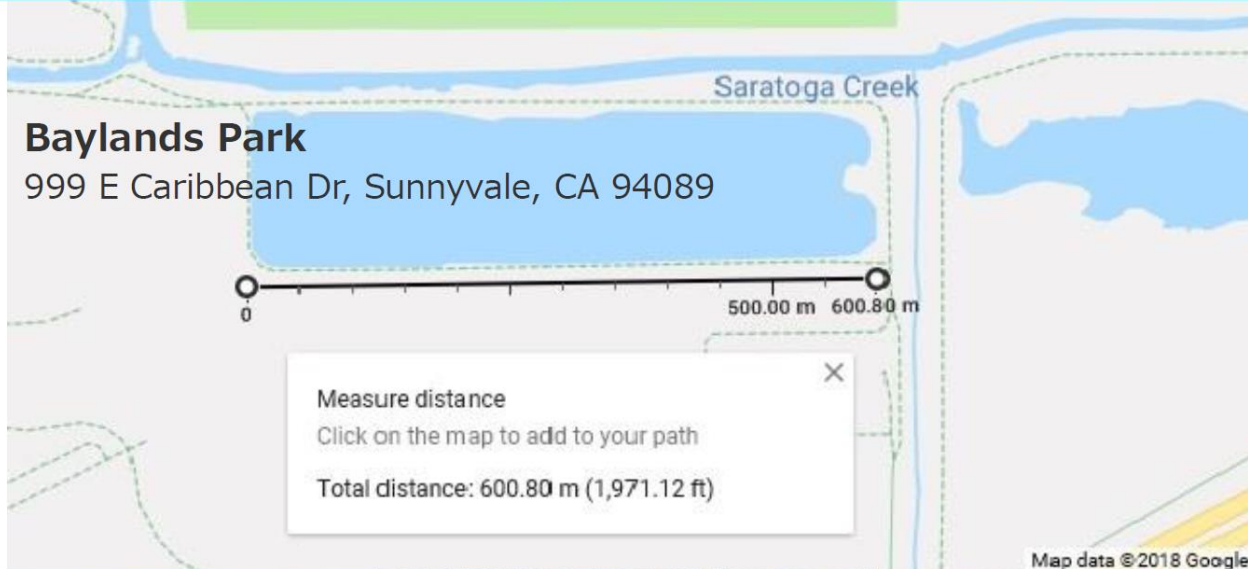

Coded PHY Results

Distance Measurement of TC35680

600m communication distance has been demonstrated.

Test date: April 25th, 2018

Test condition: Coded_PHY(125kbps) and TX Power +8dBm, Link budget 113dB

Test results:

Antenna height	Connection	Advertise
1.5m	400m(1312feet)	450m(1476feet)
2.5m	500m(1640feet)	600m(1868feet)

- Connection criteria:

Maintain connection over 10 seconds and be able to read firmware characteristics.
Connection Interval 46.25ms, SVTO 1600ms

- Advertising criteria:

To receive advertise report at least once per 10sec.
Advertise interval 40ms

