

DWG. NO. SD 35417-9002

SIMILAR ITEM

PROJECT NO. KOR 96-038

c

B

DO NOT SCALE DRAWING  
DIMENSION IN METRIC

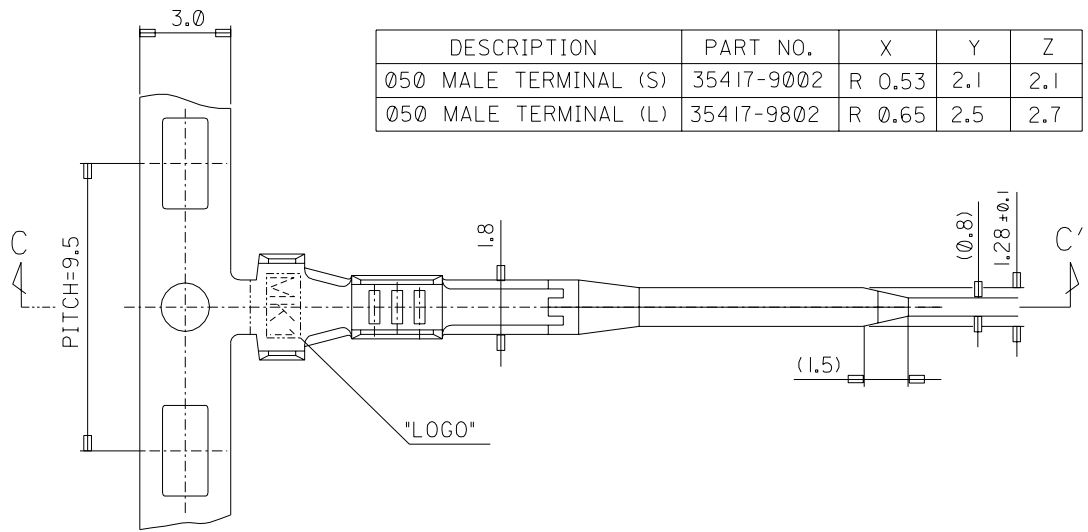

DESCRIPTION	PART NO.	X	Y	Z
Ø50 MALE TERMINAL (S)	35417-9002	R 0.53	2.1	2.1
Ø50 MALE TERMINAL (L)	35417-9802	R 0.65	2.5	2.7

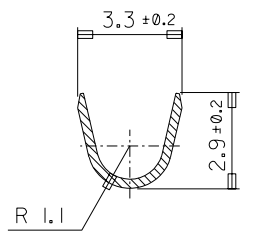

SECTION A-A'

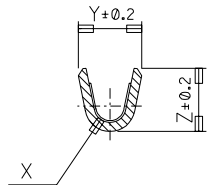

SECTION B-B'

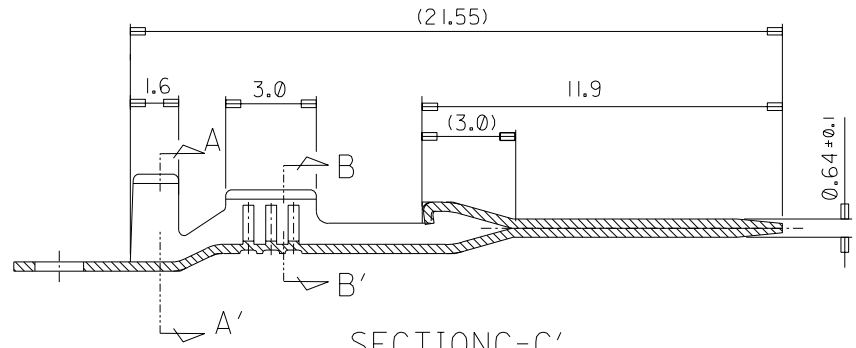

SECTION C-C'

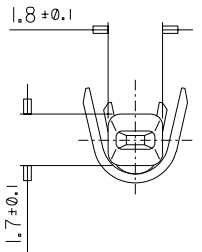

- NOTE
1. MATERIAL : BRASS (C2600), THK.=0.30±0.02
  2. FINISH : PRE-TINNED 0.9 μm MIN.
  3. WIRE RANGE : AVSS OR AVS 0.3 -- 0.85 mm. <sup>2</sup>
  4. PRODUCT SPECIFICATION : CS-35417-9002.

NEW RELEASED EC NO. KOR 99-0002 DRWN: C.Y.CHO '99.01.06 CHK: B.K.CHOI APPR: C.W.LEE	QUALITY SYMBOLS MAJOR CRITICAL	GENERAL TOLERANCES: (UNLESS SPECIFIED)		SCALE 4:1	DESIGN UNITS <input checked="" type="checkbox"/> mm <input type="checkbox"/> INCH	THIRD ANGLE PROJECTION <input checked="" type="checkbox"/> THIRD ANGLE	DIMENSIONS: <input type="checkbox"/> mm <input type="checkbox"/> INCH <input checked="" type="checkbox"/> mm ONLY	SHT REV		
		4 PLACES ±.	3 PLACES ±.	2 PLACES ±.	1 PLACE ±0.30	ANGULAR: ± 1°	DRAFT WHERE APPLICABLE MUST REMAIN WITHIN DIMENSIONS	DRAWN BY & DATE C.Y.CHO 1998/05/18		
		CHECKED BY & DATE B.K.CHOI 1998/05/18			APPROVED BY & DATE C.W.LEE 1998/05/18			TITLE: .Ø50 MALE TER'L		
		CAD FILENAME SD35417.DGN			MATERIAL NO. SD 35417-9002	DRAWING NO. SD 35417-9002	SHEET NO. 1/1	MOLEX INCORPORATED KOREA		
THIS DRAWING CONTAINS INFORMATION THAT IS PROPRIETARY TO MOLEX INCORPORATED AND SHOULD NOT BE USED WITHOUT WRITTEN PERMISSION.						SIZE B				