

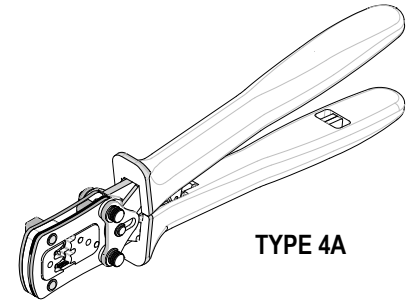

Hand Crimp Tool Specification Sheet Order No. 63811-1100



FEATURES

- % A full cycle ratcheting hand tool ensures complete crimps
- % Ergonomically designed soft handles
- % Precisely designed crimping profiles with simple contact positioning
- % Easy handling due to outstanding force ratio
- % Modular Crimp Head is removable and can be use in the Air Powered Tool Order No.63816-0100, accompanied by Air Powered Crimp Adapter (Order No. 63816-0700).
- % Can also be used in the Battery Powered Tool Order No.63816-0200, accompanied by Battery Powered Crimp Adapter (Order No. 63816-0600).

SCOPE

Products: 3.18mm (.125") Diameter HCS-125 Pin and Socket Crimp Terminals, 10-14 AWG.

Terminal Series No.	Terminal Order No.		Wire Size		Insulation Diameter		Strip Length	
	Loose Piece	● Reel	AWG	mm ²	mm	In.	mm	In.
1900	18-12-2602	18-12-2601	10-14	5.25-2.00	3.56-4.57	.140-.180	4.06-5.59	.160-.220
1901	18-12-1602	18-12-1601	10-14	5.25-2.00	3.56-4.57	.140-.180	4.06-5.59	.160-.220
42546		18-12-1607	10-14	5.25-2.00	3.56-4.57	.140-.180	4.06-5.59	.160-.220
42547	18-12-1604	18-12-1603	10-14	5.25-2.00	3.56-4.57	.140-.180	4.06-5.59	.160-.220

● Follow the Cut-Off Tab specifications on Applicator specification sheets.
These Terminals cannot be removed from the reel by manual cutting.
An applicator must be used or the terminals will not function properly.

DEFINITION OF TERMS

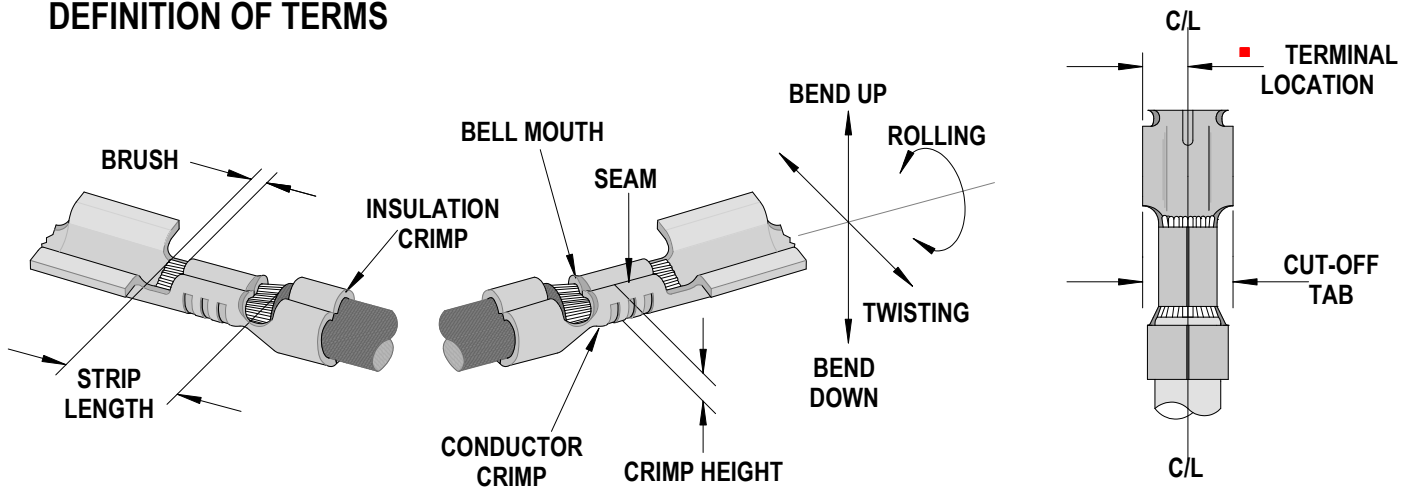

- Terminal is to be centrally located between the two (2) cut-off tab edges by one half of the total cut-off tab tolerance.

This illustration is a generic terminal representation and not an exact image of any terminal listed in the scope.

CONDITIONS:

After crimping, the crimp profiles should measure the following (see notes on page 4).

Terminal Series No.	Wire Size		Conductor Crimp				Pull Force Minimum		Profile	
			Height (Ref)		Width (Ref)					
	AWG	mm ²	mm	In.	mm	In.	N	Lb.	A	B
1900	14	2.00	1.90-2.00	.075-.079	3.91	.154	222.4	50.00	X	
	12	3.30	2.08-2.18	.082-.086	3.91	.154	311.4	70.00	X	
	10	5.25	2.24-2.34	.088-.092	4.01	.158	355.9	80.00		X
1901	14	2.00	1.90-2.00	.075-.079	3.91	.154	222.4	50.00	X	
	12	3.30	2.08-2.18	.082-.086	3.91	.154	311.4	70.00	X	
	10	5.25	2.24-2.34	.088-.092	4.01	.158	355.9	80.00		X
42546	14	2.00	1.90-2.00	.075-.079	3.91	.154	222.4	50.00	X	
	12	3.30	2.08-2.18	.082-.086	3.91	.154	311.4	70.00	X	
	10	5.25	2.24-2.34	.088-.092	4.01	.158	355.9	80.00		X
42547	14	2.00	1.90-2.00	.075-.079	3.91	.154	222.4	50.00	X	
	12	3.30	2.08-2.18	.082-.086	3.91	.154	311.4	70.00	X	
	10	5.25	2.24-2.34	.088-.092	4.01	.158	355.9	80.00		X

OPERATION

Open the tool by squeezing the handles together, at the end of the closing stroke, the ratchet mechanism will release the handles, and the hand tool will spring open.

Crimping Terminals

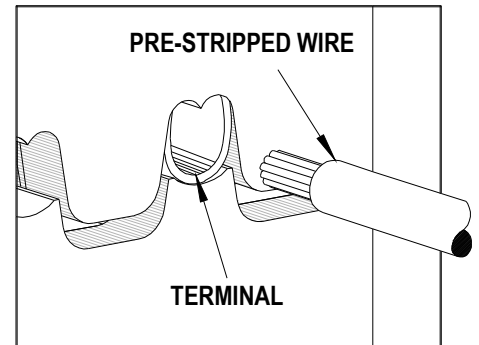

Figure 1

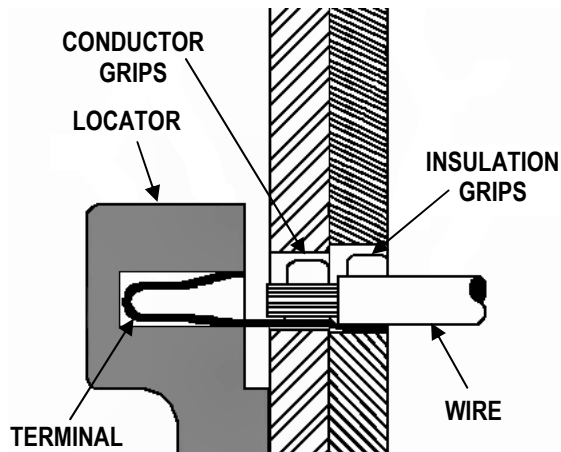

Figure 2

1. Place the terminal into the correct die profile (A or B) until the terminal stopped by the locator.
2. Partially close the tool until the terminal is held in place.
3. Place a pre-stripped wire into the terminal and align the wire with the conductor and insulation grips visually. See Figure 2.
4. Close the tool until the ratchet releases.
5. Carefully remove the crimped terminal.

Note: The tamper proof ratchet action will not release the tool until it has been fully closed.

Maintenance

It is recommended that each operator of the tool be made aware of, and responsible for, the following maintenance steps:

1. Remove dust, moisture, and other contaminants with a clean brush, or soft, lint free cloth.
2. Do not use any abrasive materials that could damage the tool.
3. Make certain all pins; pivot points and bearing surfaces are protected with a thin coat of high quality machine oil. Do not oil excessively. The tool was engineered for durability but like any other equipment it needs cleaning and lubrication for a maximum service life of trouble free crimping. Light oil (such as 30 weight automotive oil) used at the oil points, every 5,000 crimps or 3 months, will significantly enhance the tool life.
4. Wipe excess oil from hand tool, particularly from crimping area. Oil transferred from the crimping area onto certain terminations may affect the electrical characteristics of an application.
5. When tool is not in use, keep the handles closed to prevent objects from becoming lodged in the crimping dies, and store the tool in a clean, dry area.

Miscrimps or Jams

Should this tool ever become stuck or jammed in a partially closed position, **Do Not force the handles open or closed**. The tool will open easily by lifting the ratchet release lever. See Figure 3.

Warranty

This tool is for electrical terminal crimping purposes only. This tool is made of the best quality materials. All vital components are long life tested. All tools are warranted to be free of manufacturing defects for a period of 30 days. Should such a defect occur, we will repair or exchange the tool free of charge. This repair or exchange will not be applicable to altered, misused, or damaged tools. This tool is designed for hand use only. Any clamping, fixturing, or use of handle extensions voids this warranty.

CAUTION: Repetitive use of this tool should be avoided.

CAUTIONS:

1. Manually powered hand tools are intended for low volume or field repair. This tool is **NOT** intended for production use. Repetitive use of this tool should be avoided.
2. Insulated rubber handles are not protection against electrical shock.
3. Wear eye protection at all times.
4. Use only the Molex terminals specified for crimping with this tool.

Notes:

1. This tool should only be used for the terminals and wire gauges specified on this sheet.
2. This tool is not adjustable for crimp height, however crimp force is adjustable (See instructions above). Variations in tools, terminals, wire stranding and insulation types may affect crimp height.
3. This tool is intended for standard conductor sizes. It may not give a good insulation crimp support for all insulation sizes.
4. Molex does not repair hand tools (see warranty above) The replacement parts listed are the only parts available for repair. If the handles or crimp tooling is damaged or worn, a new tool must be purchased.
5. Pull force should be used as the final criteria for an acceptable crimp. Pull force is measured with no influence from the insulation crimp. The insulation should be stripped long (1/2 in.) so the insulation grips on the terminal do not grip the wire insulation or the conductor. Refer to Molex Quality Crimping Handbook 63800-0029 for additional information on crimping and crimp testing.
6. Molex does not certify crimp hand tools.

CAUTION: Molex crimp specifications are valid only when used with Molex terminals and tooling.

PARTS LIST

Item	Order Number	Description	Quantity
1	63811-1170	Modular Crimp Head	1 (ref)
2	63816-0050	Hand Crimp Frame (Long)	1 (ref)
3	63811-1175	Locator	1
4	63816-0001	Locking Pin	2
5	63600-0525	Handle Spring	1
6	63600-0520	Crimping Spring	2

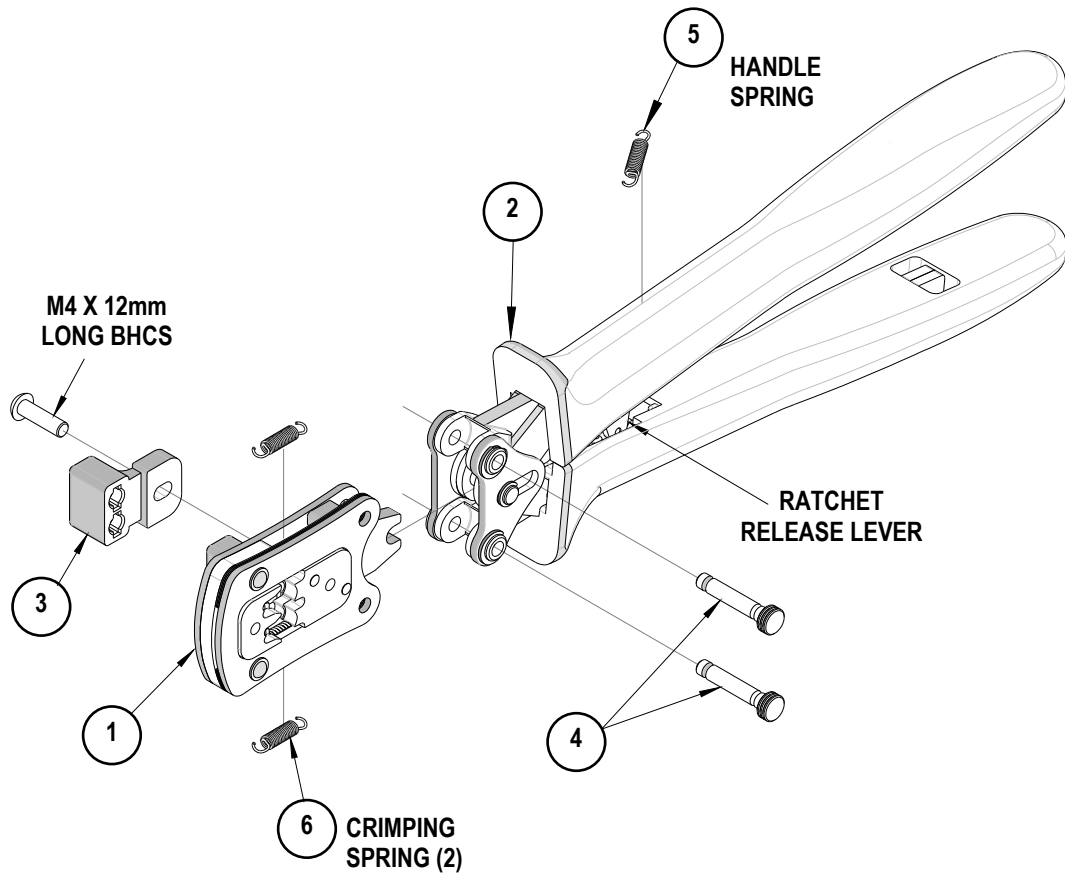

Figure 3

Americas Headquarters
 Lisle, Illinois 60532 U.S.A.
 1-800-78MOLEX
 amerinfo@molex.com

Far East North Headquarters
 Yamato, Kanagawa, Japan
 81-462-65-2324
 feninfo@molex.com

Far East South Headquarters
 Jurong, Singapore
 65-6-268-6868
 fesinfo@molex.com

European Headquarters
 Munich, Germany
 49-89-413092-0
 eurinfo@molex.com

Corporate Headquarters
 2222 Wellington Ct.
 Lisle, IL 60532 U.S.A.
 630-969-4550
 Fax: 630-969-1352

Visit our Web site at <http://www.molex.com>