

Part Number: AA3528P3S

### Features

- Mechanically and spectrally matched to the infrared emitting LED lamp.
- Package : 2000pcs / reel.
- Moisture sensitivity level : level 3.
- RoHS compliant.

### Description

Made with NPN silicon phototransistor chips.

### Package Dimensions

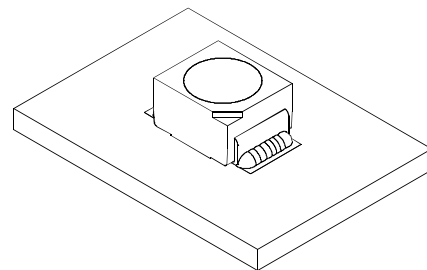
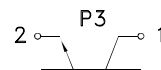
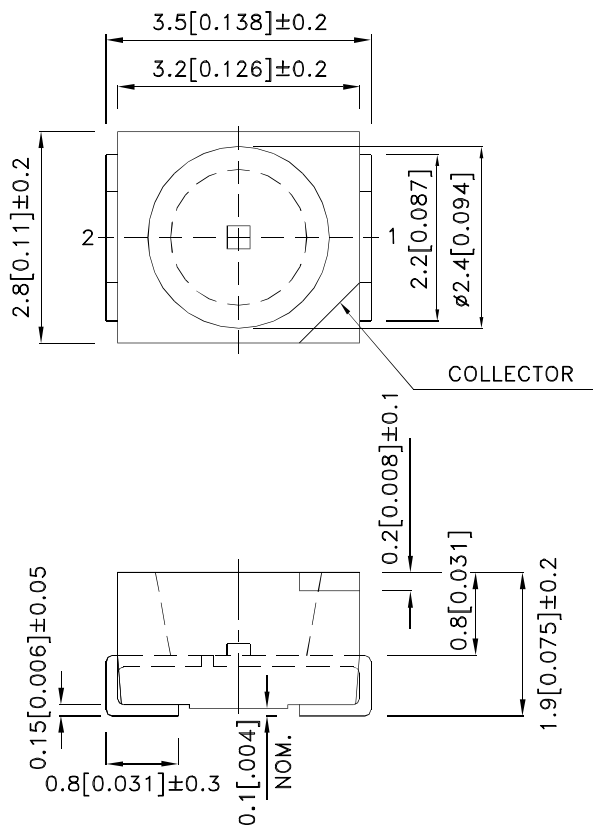

#### Notes:

1. All dimensions are in millimeters (inches).
2. Tolerance is ±0.25(0.01") unless otherwise noted.
3. The specifications, characteristics and technical data described in the datasheet are subject to change without prior notice.
4. The device has a single mounting surface. The device must be mounted according to the specifications.



## Handling Precautions

Compare to epoxy encapsulant that is hard and brittle, silicone is softer and flexible. Although its characteristic significantly reduces thermal stress, it is more susceptible to damage by external mechanical force.

As a result, special handling precautions need to be observed during assembly using silicone encapsulated LED products. Failure to comply might lead to damage and premature failure of the LED.

1. Handle the component along the side surfaces by using forceps or appropriate tools.

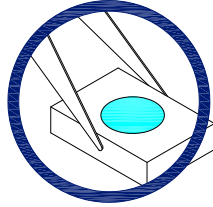

2. Do not directly touch or handle the silicone lens surface. It may damage the internal circuitry.

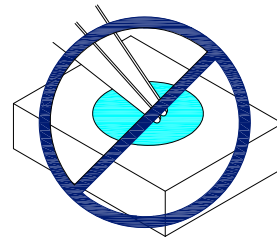
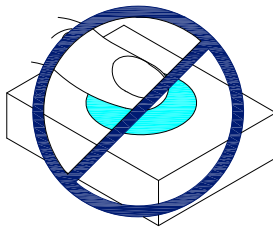

3. Do not stack together assembled PCBs containing exposed LEDs. Impact may scratch the silicone lens or damage the internal circuitry.

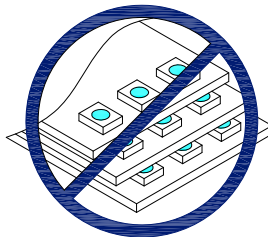

- 4.1. The inner diameter of the SMD pickup nozzle should not exceed the size of the LED to prevent air leaks.
- 4.2. A pliable material is suggested for the nozzle tip to avoid scratching or damaging the LED surface during pickup.
- 4.3. The dimensions of the component must be accurately programmed in the pick-and-place machine to insure precise pickup and avoid damage during production.

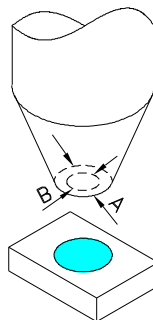

5. As silicone encapsulation is permeable to gases, some corrosive substances such as  $H_2S$  might corrode silver plating of leadframe. Special care should be taken if an LED with silicone encapsulation is to be used near such substances.

## Electrical / Optical Characteristics at TA=25°C

Symbol	Parameter	Min.	Typ.	Max.	Units	Test Conditions
V <sub>BR CEO</sub>	Collector-to-Emitter Breakdown Voltage	30			V	I <sub>C</sub> =100uA E <sub>e</sub> =0mW/cm <sup>2</sup>
V <sub>BR ECO</sub>	Emitter-to-Collector Breakdown Voltage	5			V	I <sub>E</sub> =100uA E <sub>e</sub> =0mW/cm <sup>2</sup>
V <sub>CE (SAT)</sub>	Collector-to-Emitter Saturation Voltage			0.8	V	I <sub>C</sub> =2mA E <sub>e</sub> =20mW/cm <sup>2</sup>
I <sub>CEO</sub>	Collector Dark Current			100	nA	V <sub>CE</sub> =10V E <sub>e</sub> =0mW/cm <sup>2</sup>
T <sub>R</sub>	Rise Time (10% to 90% )		15		us	V <sub>CE</sub> = 5V I <sub>C</sub> =1mA R <sub>L</sub> =1000Ω
T <sub>F</sub>	Fall Time (90% to 10% )		15		us	
I <sub>(ON)</sub>	On State Collector Current	0.2	0.4		mA	V <sub>CE</sub> = 5V E <sub>e</sub> =1mW/cm <sup>2</sup> λ=940nm
λ <sub>0.1</sub>	Range of spectral bandwidth	420		1120	nm	
λ <sub>p</sub>	Wavelength of peak sensitivity		940		nm	
2θ <sub>1/2</sub>	Angle of half sensitivity		120		deg	

## Absolute Maximum Ratings at TA=25°C

Parameter	Max.Ratings
Collector-to-Emitter Voltage	30V
Emitter-to-Collector Voltage	5V
Power Dissipation at (or below) 25°C Free Air Temperature	100mW
Operating Temperature	-40°C To +85°C
Storage Temperature	-40°C To +85°C

Note:

- Relative humidity levels maintained between 40% and 60% in production area are recommended to avoid the build-up of static electricity – Ref JEDEC/JESD625-A and JEDEC/J-STD-033.

### Typical Electro-Optical Characteristics Curves

Fig.1 Collector Power Dissipation vs. Ambient Temperature

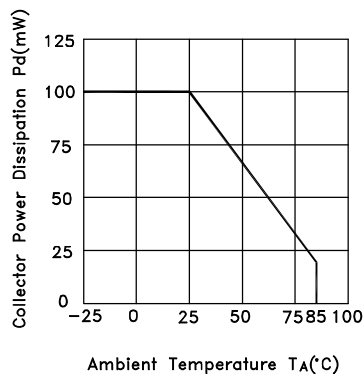

Fig.2 Spectral Sensitivity vs. Wavelength

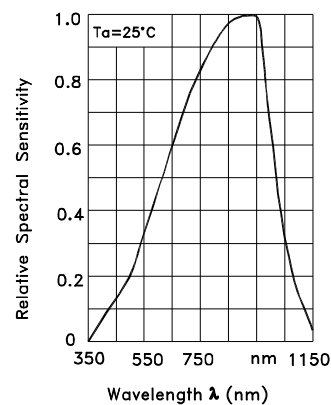

Fig.3 Relative Collector Current vs. Ambient Temperature

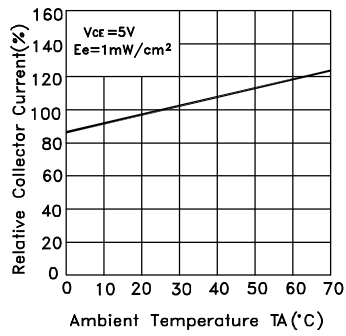

Fig.4 Collector Current  
 $I_c = f(E_e), V_{ce}=5V, T_a=25^\circ C$

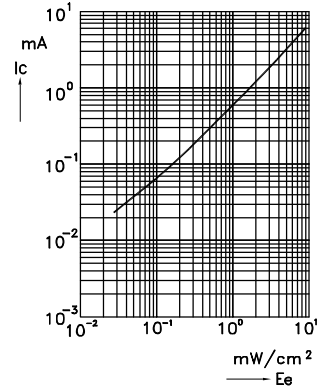

Fig.5 Collector Dark Current vs. Ambient Temperature

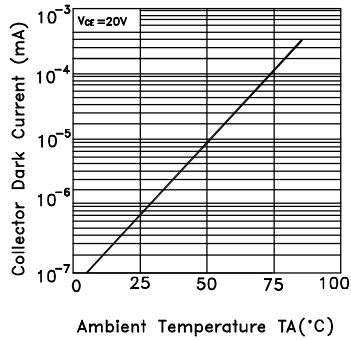

Fig.6 Collector Current vs. Collector-Emitter Voltage

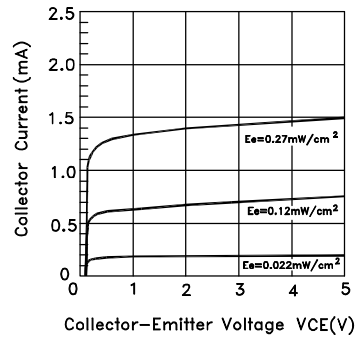
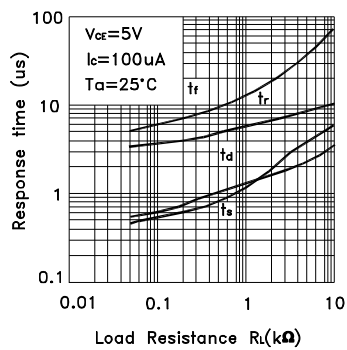
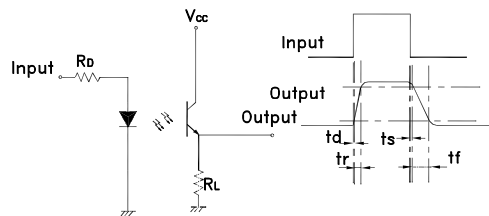

Fig.7 Response Time vs. Load Resistance



Test Circuit for Response Time



## AA3528P3S

Reflow soldering is recommended and the soldering profile is shown below.  
Other soldering methods are not recommended as they might cause damage to the product.

Reflow Soldering Profile For Lead-free SMT Process.

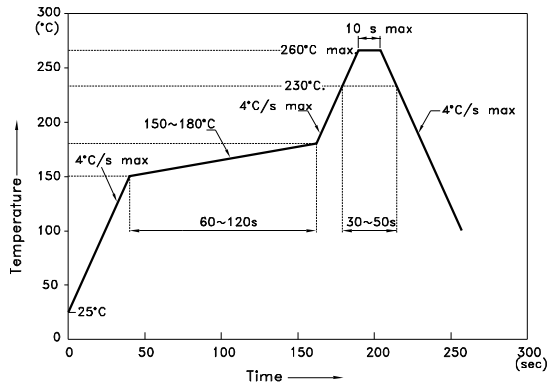

**NOTES:**

1. We recommend the reflow temperature 245°C(+/-5°C). The maximum soldering temperature should be limited to 260°C.
2. Don't cause stress to the epoxy resin while it is exposed to high temperature.
3. Number of reflow process shall be 2 times or less.

### Recommended Soldering Pattern (Units : mm; Tolerance: ± 0.1)

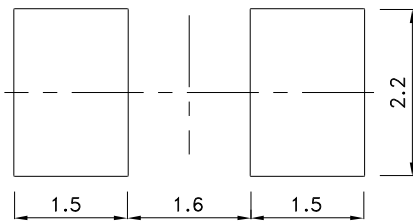

### Reel Dimension

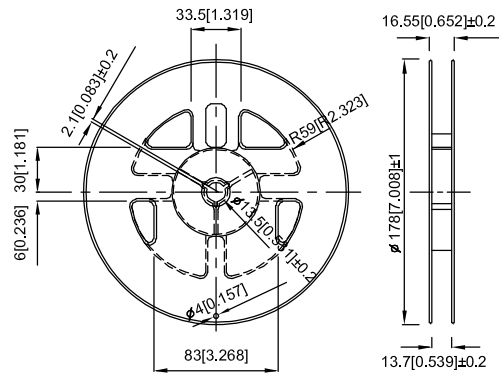

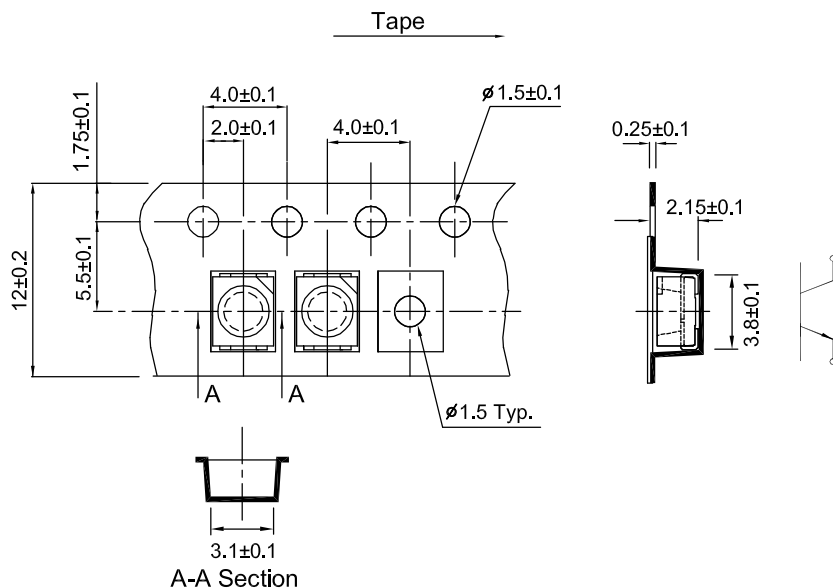

### Tape Specifications (Units : mm)

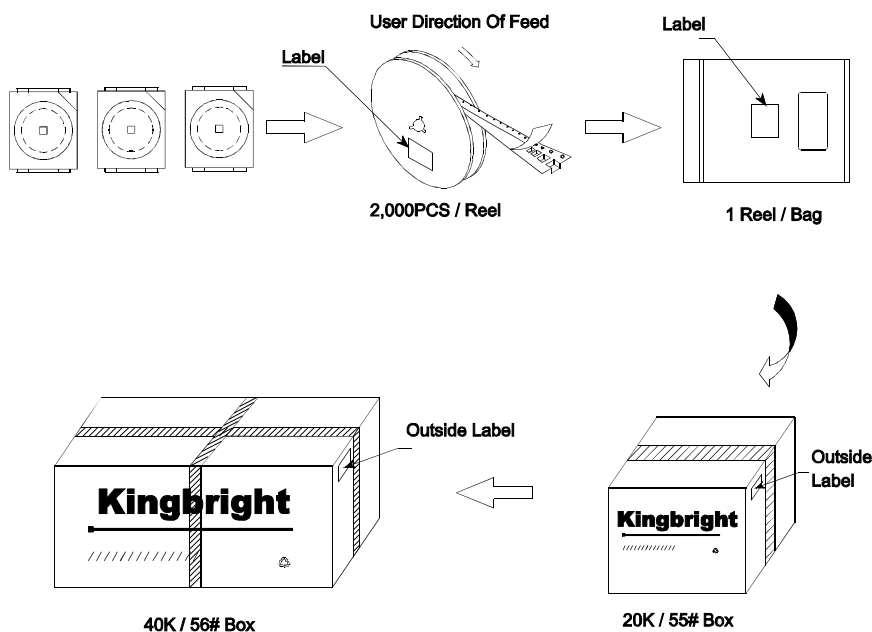

## PACKING & LABEL SPECIFICATIONS

## AA3528P3S



<b>Kingbright</b>		
P/NO: AA3528XXX		
QTY: 2,000 PCS	Q.C.	Q.C. XXXXXXX PASSED
S/N: XXXX		
CODE: XXX		
LOT NO:		
 XXXXXXXXXXXXXXXXXXXXXXXX		
RoHS Compliant		

### Terms and conditions for the usage of this document

1. The information included in this document reflects representative usage scenarios and is intended for technical reference only.
2. The part number, type, and specifications mentioned in this document are subject to future change and improvement without notice. Before production usage customer should refer to the latest datasheet for the updated specifications.
3. When using the products referenced in this document, please make sure the product is being operated within the environmental and electrical limits specified in the datasheet. If customer usage exceeds the specified limits, Kingbright will not be responsible for any subsequent issues.
4. The information in this document applies to typical usage in consumer electronics applications. If customer's application has special reliability requirements or have life-threatening liabilities, such as automotive or medical usage, please consult with Kingbright representative for further assistance.
5. The contents and information of this document may not be reproduced or re-transmitted without permission by Kingbright.
6. All design applications should refer to Kingbright application notes available at <http://www.KingbrightUSA.com/ApplicationNotes>