

# EVAL-M1-IM323 user guide

## iMotion™ modular application design kit

### About this document

#### Scope and purpose

This user guide provides an overview of the evaluation board EVAL-M1-IM323 including its main features, key data, pin assignments, and mechanical dimensions.

This evaluation board has been developed to provide initial support to customers in designing motor drive applications for major home appliances such as air conditioners, pumps, fans, and other variable-speed drives.

The EVAL-M1-IM323 is part of the iMOTION™ modular application design kit (MADK). Together with a control board equipped with the M1 20-pin interface connector, such as the EVAL-M1-101T, it features and demonstrates the Infineon CIPOS™ Tiny intelligent power module (IPM) technology and advanced motion control engine (MCE 2.0) technology for permanent magnet motor drives. EVAL-M1-IM323 is based on the IM323-L6Gx CIPOS™ Tiny IPM. The IM323-L6Gx is designed to control 3-phase AC motors and permanent magnet motors in variable-speed drives. It works with a voltage of 600 V and provides a current rating of 15 A.

#### Intended audience

This user guide is intended for all technical specialists who know motor control and low-power electronic converters. The evaluation board is intended to be used under laboratory conditions.

#### Evaluation Board

This evaluation board is to be used during the design-in process for evaluating and measuring characteristic curves, and for checking datasheet specifications.

*Note: PCB and auxiliary circuits are NOT optimized for final customer design.*



**Figure 1** The iMotion™ MADK evaluation board for IM323-L6Gx CIPOS™ Tiny IPM

**About this document**

Important notice

**“Evaluation Boards and Reference Boards” shall mean products embedded on a printed circuit board (PCB) for demonstration and/or evaluation purposes, which include, without limitation, demonstration, reference and evaluation boards, kits and design (collectively referred to as “Reference Board”).**

**Environmental conditions have been considered in the design of the Evaluation Boards and Reference Boards provided by Infineon Technologies. The design of the Evaluation Boards and Reference Boards has been tested by Infineon Technologies only as described in this document. The design is not qualified in terms of safety requirements, manufacturing and operation over the entire operating temperature range or lifetime.**

**The Evaluation Boards and Reference Boards provided by Infineon Technologies are subject to functional testing only under typical load conditions. Evaluation Boards and Reference Boards are not subject to the same procedures as regular products regarding returned material analysis (RMA), process change notification (PCN) and product discontinuation (PD).**

**Evaluation Boards and Reference Boards are not commercialized products, and are solely intended for evaluation and testing purposes. In particular, they shall not be used for reliability testing or production. The Evaluation Boards and Reference Boards may therefore not comply with CE or similar standards (including but not limited to the EMC Directive 2004/EC/108 and the EMC Act) and may not fulfill other requirements of the country in which they are operated by the customer. The customer shall ensure that all Evaluation Boards and Reference Boards will be handled in a way which is compliant with the relevant requirements and standards of the country in which they are operated.**

**The Evaluation Boards and Reference Boards as well as the information provided in this document are addressed only to qualified and skilled technical staff, for laboratory usage, and shall be used and managed according to the terms and conditions set forth in this document and in other related documentation supplied with the respective Evaluation Board or Reference Board.**

**It is the responsibility of the customer’s technical departments to evaluate the suitability of the Evaluation Boards and Reference Boards for the intended application, and to evaluate the completeness and correctness of the information provided in this document with respect to such application.**

**The customer is obliged to ensure that the use of the Evaluation Boards and Reference Boards does not cause any harm to persons or third party property.**

**The Evaluation Boards and Reference Boards and any information in this document is provided "as is" and Infineon Technologies disclaims any warranties, express or implied, including but not limited to warranties of non-infringement of third party rights and implied warranties of fitness for any purpose, or for merchantability.**

**Infineon Technologies shall not be responsible for any damages resulting from the use of the Evaluation Boards and Reference Boards and/or from any information provided in this document. The customer is obliged to defend, indemnify and hold Infineon Technologies harmless from and against any claims or damages arising out of or resulting from any use thereof.**

**Infineon Technologies reserves the right to modify this document and/or any information provided herein at any time without further notice.**

**Safety precautions**

**Safety precautions**

Note: Please note the following warnings regarding the hazards associated with development systems.

**Table 1 Safety precautions**

	<p><b>Warning:</b> The DC link potential of this board is up to 400 V<sub>DC</sub>. When measuring voltage waveforms by oscilloscope, high voltage differential probes must be used. Failure to do so may result in personal injury or death.</p>
	<p><b>Warning:</b> The evaluation or reference board contains DC bus capacitors which take time to discharge after removal of the main supply. Before working on the drive system, wait five minutes for capacitors to discharge to safe voltage levels. Failure to do so may result in personal injury or death. Darkened display LEDs are not an indication that capacitors have discharged to safe voltage levels.</p>
	<p><b>Warning:</b> The evaluation or reference board is connected to the grid input during testing. Hence, high-voltage differential probes must be used when measuring voltage waveforms by oscilloscope. Failure to do so may result in personal injury or death. Darkened display LEDs are not an indication that capacitors have discharged to safe voltage levels.</p>
	<p><b>Warning:</b> Remove or disconnect power from the drive before you disconnect or reconnect wires, or perform maintenance work. Wait five minutes after removing power to discharge the bus capacitors. Do not attempt to service the drive until the bus capacitors have discharged to zero. Failure to do so may result in personal injury or death.</p>
	<p><b>Caution:</b> The heat sink and device surfaces of the evaluation or reference board may become hot during testing. Hence, necessary precautions are required while handling the board. Failure to comply may cause injury.</p>
	<p><b>Caution:</b> Only personnel familiar with the drive, power electronics and associated machinery should plan, install, commission and subsequently service the system. Failure to comply may result in personal injury and/or equipment damage.</p>
	<p><b>Caution:</b> The evaluation or reference board contains parts and assemblies sensitive to electrostatic discharge (ESD). Electrostatic control precautions are required when installing, testing, servicing or repairing the assembly. Component damage may result if ESD control procedures are not followed. If you are not familiar with electrostatic control procedures, refer to the applicable ESD protection handbooks and guidelines.</p>
	<p><b>Caution:</b> A drive that is incorrectly applied or installed can lead to component damage or reduction in product lifetime. Wiring or application errors such as undersizing the motor, supplying an incorrect or inadequate AC supply, or excessive ambient temperatures may result in system malfunction.</p>
	<p><b>Caution:</b> The evaluation or reference board is shipped with packing materials that need to be removed prior to installation. Failure to remove all packing materials that are unnecessary for system installation may result in overheating or abnormal operating conditions.</p>

**Table of contents**

**About this document..... 1**

**Safety precautions..... 3**

**Table of contents..... 4**

**1 The board at a glance..... 5**

1.1 Scope of supply .....5

1.2 Block diagram.....5

1.3 Main features .....7

1.4 Board parameters and technical data.....7

**2 System and functional description .....10**

2.1 Getting started.....10

2.2 Description of functional blocks.....15

2.2.1 Overview of IM323-L6Gx.....15

2.2.2 Overview of ICE5AR4770BZS.....17

2.2.3 Motor external current feedback configuration and calculation .....17

**3 System design.....19**

3.1.1 EMI filter and soft power-up circuit .....19

3.1.2 Inverter section using CIPOST™ Tiny IPM .....19

3.1.3 Auxiliary power supply.....20

3.2 Layout .....21

3.3 Bill of material .....24

3.4 Connector details .....31

3.5 Test points .....32

**4 System performance .....34**

4.1 Input voltage range test .....34

4.2 Bus capacitors and  $V_{DC}$  ripple.....35

4.3 Output current and PWM frequency range test .....36

4.4 Case temperature of IPM vs. output power and  $V_{TH}$ .....38

4.5 Heat sink thermal resistance test result.....40

4.6 Auxiliary power supply .....41

4.7 Inrush current test.....43

4.8 Overcurrent protection (OCP).....44

4.9 Short-protection.....46

4.10 Overvoltage protection (OVP) .....48

4.11 EMC test .....49

4.12 Surge test.....51

4.13 Electrical fast transient (EFT) test.....51

**Acronyms.....53**

**References.....55**

**Revision history.....56**

**Disclaimer.....57**

## **1 The board at a glance**

The EVAL-M1-IM323 evaluation power board is part of the iMOTION™ modular application design kit for motor drives (iMOTION™ MADK). The MADK platform is intended to be used with various power stages and different control boards. The EVAL-M1-IM323 can be easily connected to a control board such as the EVAL-M1-101T through the 20-pin iMOTION™ MADK M1 connector. The EVAL-M1-101T control board is designed to control a single motor.

The EVAL-M1-IM323 is available through regular Infineon distribution partners and through Infineon's website. This user guide details the features of the evaluation board (Section 1.3 ) and provides information on how customers can copy, modify, and qualify the design for production according to their specific requirements.

Environmental conditions were considered in the design of the EVAL-M1-IM323, but the evaluation board is not qualified, in terms of safety requirements, for manufacturing and operation over the entire operating temperature range or lifetime. The boards provided by Infineon are subjected to functional testing only.

The evaluation boards are not subject to the same procedures as regular products regarding returned material analysis (RMA), process change notification (PCN), and product discontinuation (PD). Evaluation boards are intended to be used under laboratory conditions by technical specialists only.

### **1.1 Scope of supply**

The EVAL-M1-IM323 evaluation board is designed to provide an easy-to-use power stage based on Infineon's CIPOS™ Tiny intelligent power module (IPM) IM323-L6Gx.

The delivery includes the finished evaluation board as shown in Figure 1. It provides a single-phase AC-input connector, an EMI filter, an input rectifier, DC bus capacitors, and a 3-phase output to connect the motor. It also contains:

- A CoolSET™ based auxiliary power supply to provide output of 15 V and 3.3 V
- Emitter shunts for current sensing and overcurrent protection
- A voltage divider for DC-link voltage measurement

The evaluation board shown in Figure 1 can be operated directly with the required power supply without additional components.

### **1.2 Block diagram**

The block diagram of the EVAL-M1-IM323 board is shown in Figure 2.



**The board at a glance**

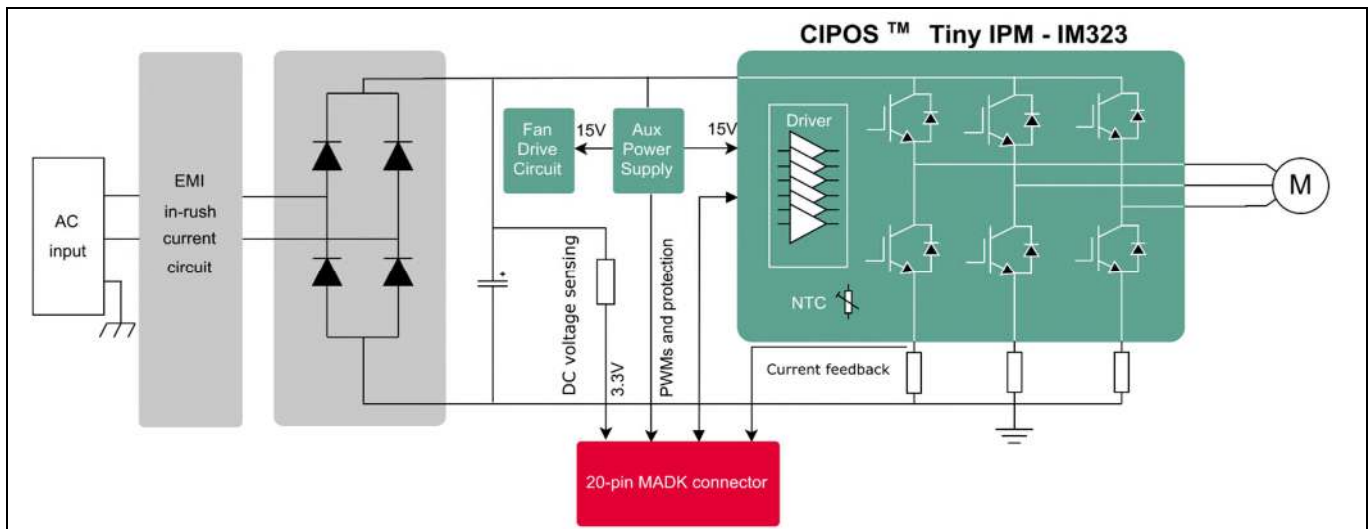

**Figure 2 Block diagram of the EVAL-M1-IM323 evaluation board**

Figure 3 shows the top-side functional groups of the EVAL-M1-IM323 board.

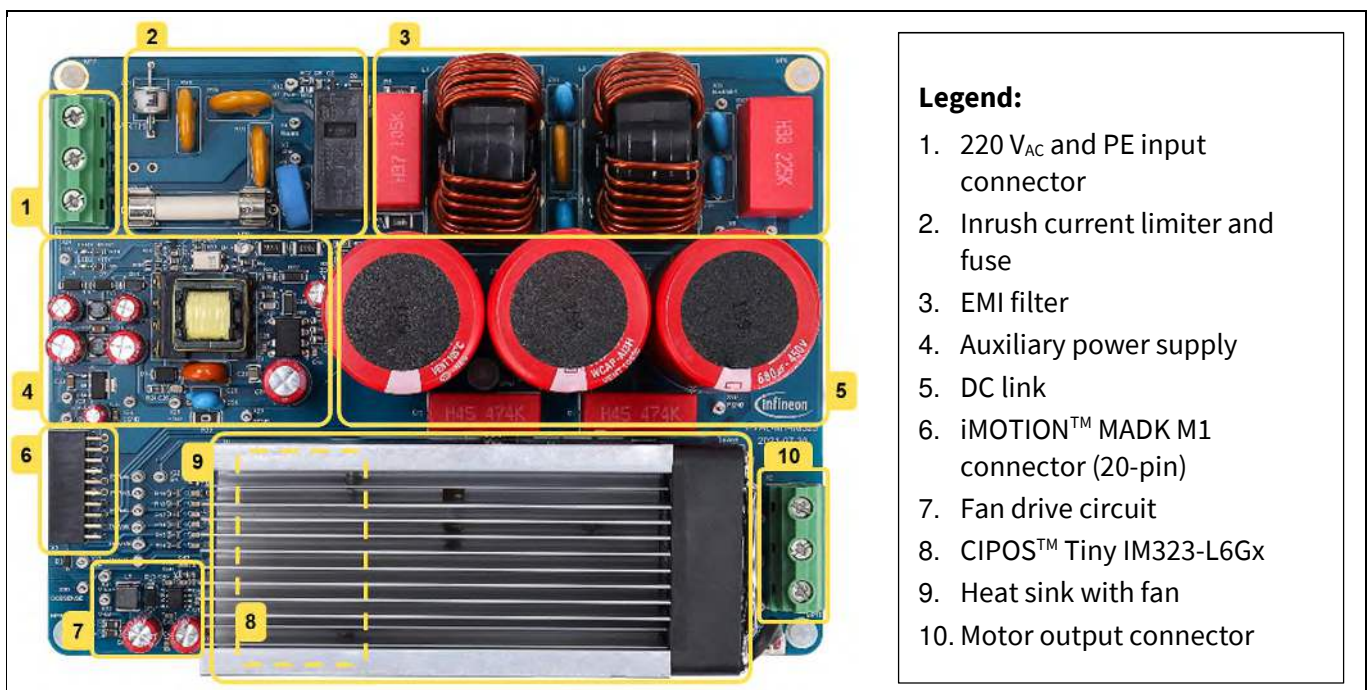

**Figure 3 Top-side functional groups of the EVAL-M1-IM323 evaluation design**

Figure 4 shows the bottom-side design of the EVAL-M1-IM323 board.

**The board at a glance**

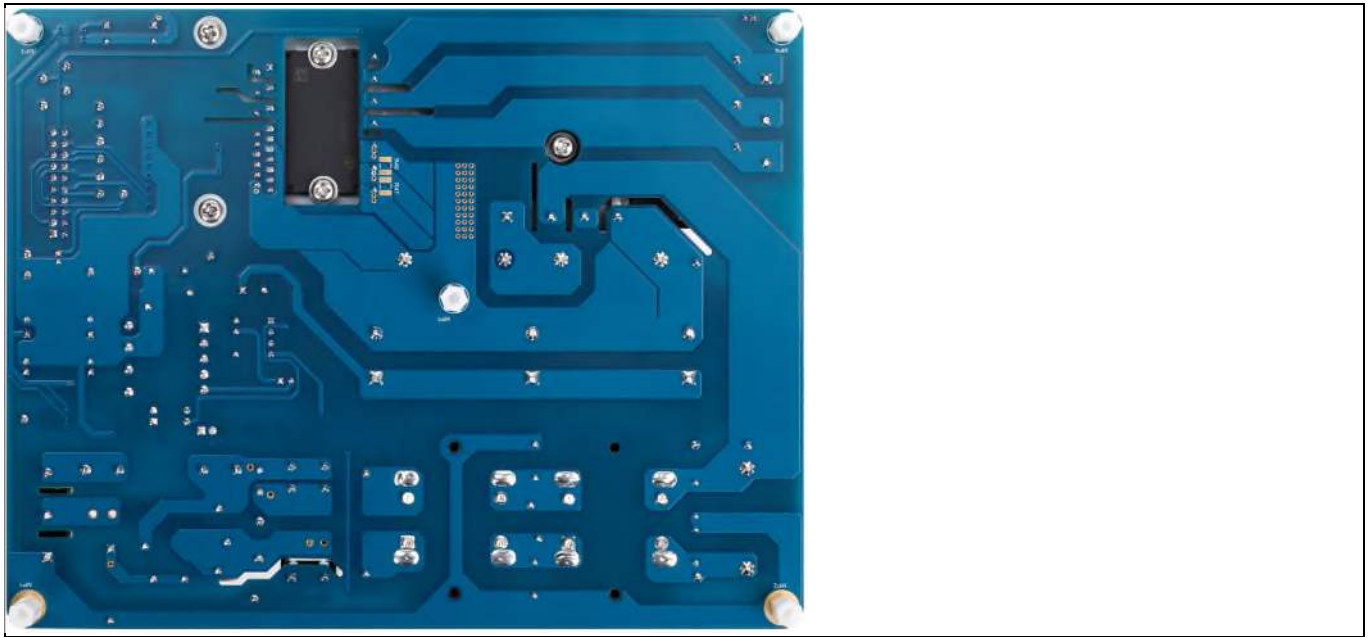

**Figure 4** Evaluation design of the EVAL-M1-IM323, bottom-side

### 1.3 Main features

The EVAL-M1-IM323 evaluation board, combined in a kit, with one of the available MADK control boards has the following features:

- Input voltage 165 V<sub>AC</sub> to 265 V<sub>AC</sub>
- Maximum 12 A input current at 165 V<sub>AC</sub>
- Maximum 1500 W motor power output at 220 V<sub>AC</sub>
- Inrush current limiter for circuit protection
- On-board EMI filter and pass EMI standards EN55032
- Auxiliary power supply with 15 V, 3.3 V
- Overcurrent hardware protection and over temperature protection
- Sensing of DC-link voltage
- Thermistor output
- Temperature controlled cooling fan speed adjustment
- PCB size is 180 mm × 140 mm, two layers with 1 oz. copper
- RoHS compliant

### 1.4 Board parameters and technical data

Table 2 lists the important specifications of the EVAL-M1-IM323.

**Table 2** Parameters

Parameter	Symbol	Conditions	Value	Unit
<b>Input</b>				
Input voltage	V <sub>AC</sub>	Lower AC input, less motor power output	165 - 265	V <sub>rms</sub>

**The board at a glance**

Parameter	Symbol	Conditions	Value	Unit
Input current	$I_{AC(max1)}$	Input 265 V <sub>AC</sub> , f <sub>PWM</sub> = 6 kHz, T <sub>A</sub> = 29°C, T <sub>C</sub> = 90°C, with heat sink	8.72	A <sub>rms</sub>
	$I_{AC(max2)}$	Input 165 V <sub>AC</sub> , f <sub>PWM</sub> = 6 kHz, T <sub>A</sub> = 29°C, T <sub>C</sub> = 90°C, with heat sink	12.59	A <sub>rms</sub>
<b>Output</b>				
Power (3-phase)	P <sub>out(max)</sub>	Input 165 V <sub>AC</sub> , f <sub>PWM</sub> = 6 kHz, T <sub>A</sub> = 29°C, T <sub>C</sub> = 90°C, with heat sink	1400	W
Current per leg	I <sub>out(max)</sub>	Input 165 V <sub>AC</sub> , f <sub>PWM</sub> = 6 kHz, T <sub>A</sub> = 29°C, T <sub>C</sub> = 90°C, with heat sink	7.788	A <sub>rms</sub>
<b>DC bus</b>				
Maximum DC-bus voltage	V <sub>DC(max)</sub>	AC input 265 V <sub>rms</sub>	355	V
Minimum DC-bus voltage	V <sub>DC(min)</sub>	AC input 165 V <sub>rms</sub>	208	V
<b>Current feedback</b>				
Shunt resistance	RS1, RS2, RS3	Leg shunt	30	mΩ



**The board at a glance**

Parameter	Symbol	Conditions	Value	Unit
<b>Protections</b>				
Overcurrent protection	$I_{OCP}$	Configured by changing shunt resistors RS1, RS2, and RS3 for current sensing	21.5 <sup>1</sup>	$A_{peak}$
<b>Auxiliary power supply</b>				
Voltage circuit (VCC) voltage output	$V_{CC}$	Used for IPM power supply	15 ±5%	V
VCC current output	$I_{VCC}$	Used for IPM power supply	100	mA
3.3 V voltage output	$V_{3.3V}$	Used for IMC101T controller and protection circuits	3.3 ±2%	V
3.3 V current output	$I_{3.3V}$	Used for IMC101T controller and protection circuits	200	mA
<b>PCB characteristics</b>				
Dimension		Length × width	180 × 140	Mm
Material		FR4, 1.6 mm thickness, 1 oz. PCB		
<b>System environment</b>				
Ambient temperature	$T_A$		29	°C

<sup>1</sup> For iMOTION™ IC IMCxxx, there are three types of gatekill input source options in the MCEWizard setup: gatekill-pin, comparator, and both. If you select the “comparator” mode, the external gatekill signal will not be used, and the signals  $I_{U+}/I_{V+}/I_{W+}$  will be compared by the internal comparator with the “Device overcurrent trigger level setting” value set in the MCEWizard.

## 2 System and functional description

### 2.1 Getting started

To run the motor system, a combination of iMOTION™ MADK power board (EVAL-M1-IM323) and a matching MADK control board (EVAL-M1-101T or other control board) is required. This chapter provides information on setting up the system and getting started with the iMOTION™ MADK development platform.

EVAL-M1-IM323 evaluation boards are tested with EVAL-M1-101T control boards that are shipped with embedded firmware and default parameters.

*Note: If you use the EVAL-M1-101T board as a controller, remove resistor R2 (4.7 k) from this evaluation board. The EVAL-M1-IM323 evaluation board contains a pull-up resistor R21 with the recommended 18 k. This improves the temperature behavior of the IM323-L6GX.*

The following actions must be performed to achieve a usable motor controller IC from a blank IMC101T:

- Programming the motion control engine (MCE)
- Programming the parameter sets for system and motor
- Programming customer scripts (optional)
- Programming the combined file for an integrated system (optional)

The iMOTION™ software tools—MCEDesigner and MCEWizard—are required for initial system setup, and to control and fine-tune the system performance to match the user’s exact needs. These tools can be downloaded from the [Infineon website](#). Please visit this page periodically to check for tools and software updates.

An iMOTION™ link or an on-board USB-to-UART cable is needed to bridge the PC/debugger side and the motor drive system (on the target iMOTION™ device, hot side) with a 1 kV DC galvanic isolation.

Figure 5 shows the basic system connection using the EVAL-M1-IM323 board to run a 3000 W GK6081-6AC31 motor with MCEDesigner. Refer to the MCEWizard and MCEDesigner documentation for more information.

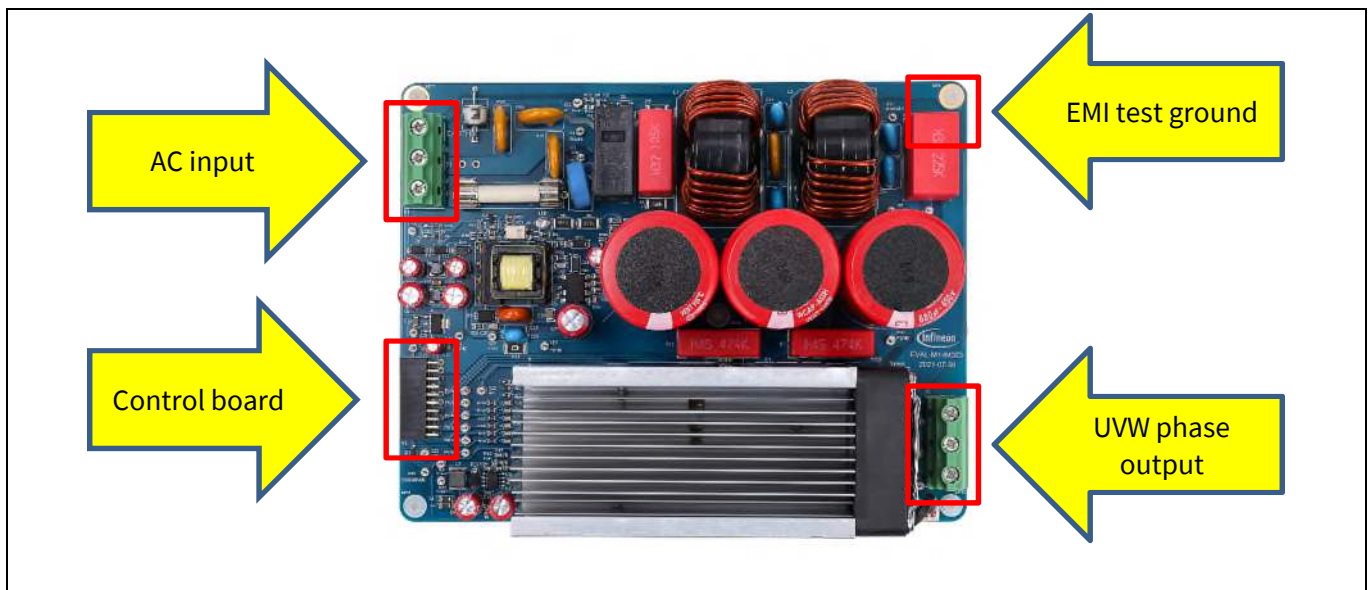

**Figure 5 Example of the system connection**

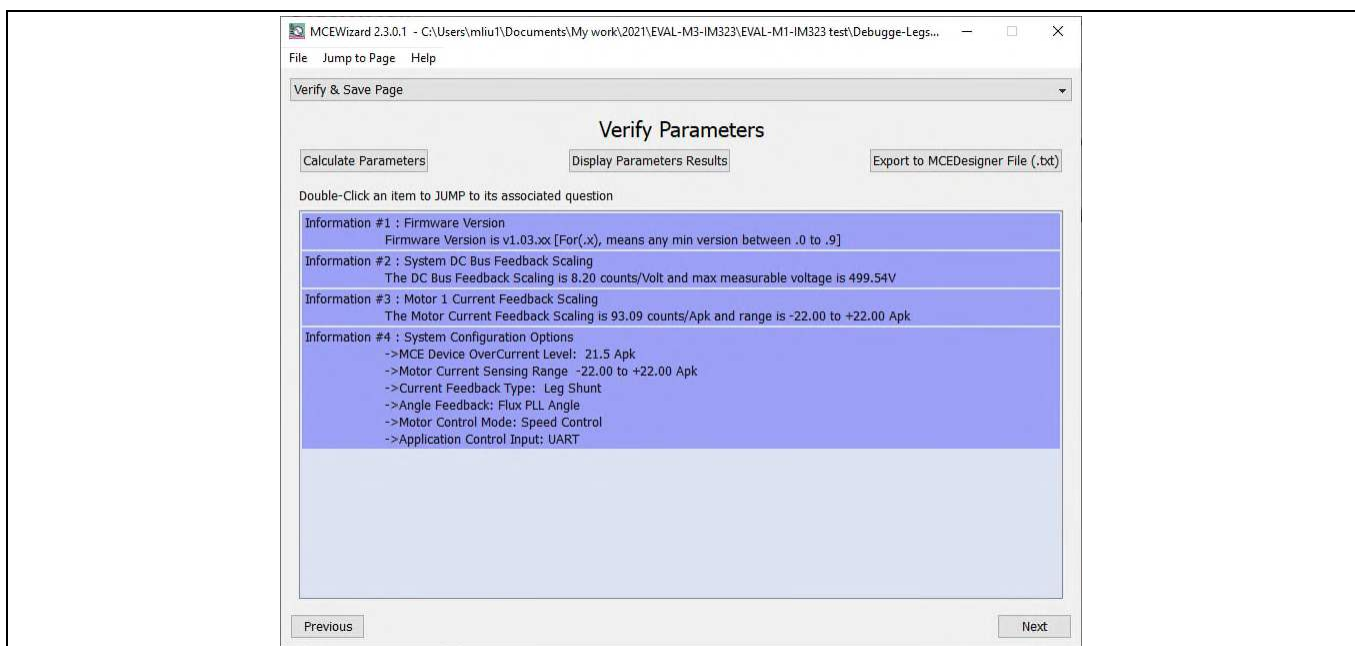

**Figure 6** MCEWizard's welcome page

After downloading and installing the MCEWizard and MCEDesigner, follow these steps to run the motor:

1. Connect the EVAL-M1-101T control board to the EVAL-M1-IM323 evaluation board. Then, connect the PC-USB connector to the EVAL-M1-101T control board.
2. Connect the 220 V AC power supply and the UVW outputs to the motor.
3. In the MCEWizard, enter the system and operating parameters of the target motor, and the hardware parameters of the evaluation board. This data is used for calculating the digital parameter set of the controller, representing the complete motor drive system.
4. After setting the system and operating parameters, go to the Verify & Save page and click **Calculate Parameters**. If no errors are reported, save the drive parameter set into your project directory by clicking **Export to MCEDesigner file (.txt)** (see Figure 7); if an error message appears, double-click the error message (highlighted in RED) and adjust the erroneous parameters. This drive-system parameter file is later used by the MCEDesigner (step 9.)

*Note:* Refer to the *MCEWizard\_V2.3.0.0 User Guide.pdf* for details. This guide is available in the MCE Wizard's installation path.



**Figure 7 MCEWizard’s Verify & Save page**

5. Turn on the 220 V AC power supply, LED 1 and 2 turn red.
6. Start the MCEDesigner tool and click **File > Open** to open the MCEDesigner default configuration file (.irc) for the IMC101T device (IMC101T\_Vxxx.irc.)  
(The IMC101T\_Vxxx.irc file is included in the downloaded IMC101T MCE software package.)
7. The MCEDesigner should automatically connect to the EVAL-M1-101T board using the default COM port (indicated by a green circle next to the “COMx Up” status in the bottom frame of the MCEDesigner GUI). If the connection cannot be established due to an incorrect COM port, change the COM port by following these steps:
  - a) Open the System Page window.
  - b) Click **Preferences > Connection > Connect using**.
  - c) Choose one of the other available COM ports from the drop-down list.
8. In case of a blank IC: If the firmware has been erased from the IMC101T, a warning message will pop up (see Figure 8)—“Target device firmware and parameters files are not programmed! Please program firmware and parameters file.” See step 9 on how to obtain/program firmware and parameters.

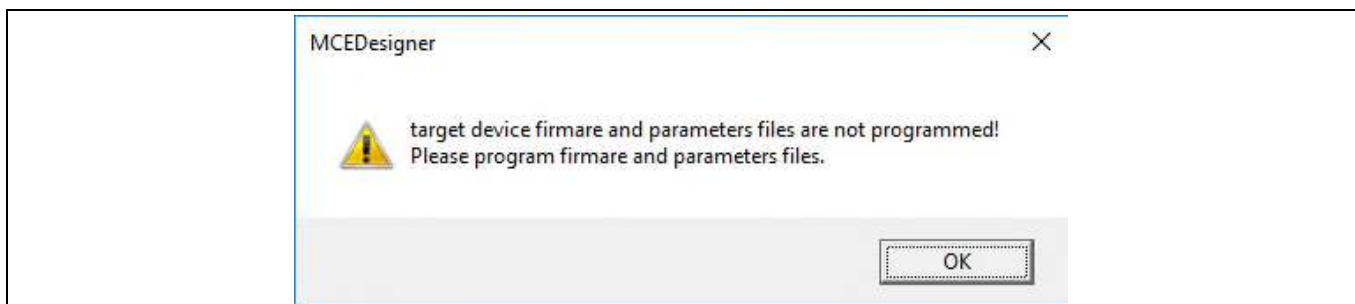

**Figure 8 MCEDesigner warning message**

9. In case of a blank IC: To program the firmware and the parameters file into the internal Flash memory of the iMOTION™ Control IC, follow these steps:
  - a) Open the System Page.

**System and functional description**

- b) Click **Tools > Programmer** and select Program Firmware and Parameters, as shown in Figure 9.  
The encrypted firmware is available in the IMC101T MCE Software Package. For the parameters file, browse and select the .txt file generated in step 4.  
If the IMC101T IC is blank, the MCEDesigner will generate a pop-up message—“Target device firmware and parameter files are not programmed!”
- c) Program the MCE firmware and system parameters into the internal Flash memory of the iMOTION™ IC by selecting **Tools > Programmer** from the pull-down menu, and then selecting the Program Firmware and Parameter check box.
- d) Select the right parameter file and firmware file.
- e) Click **Start** to program the firmware and parameter.
- f) Click **YES** and then **OK** to update the IRC file with the parameter file.
- g) Click **Save As** to save the IRC file with a file name that contains the COM config, parameters, and firmware file path information.

*Note: Refer to the MCEDesigner User Guide.pdf and the MCEDesigner\_V2.3.0.0 Application Guide.pdf (available in MCEDesigner’s install path) for details.*

After the programming is complete, the red LED1 on EVAL-M1-101T will flash on.

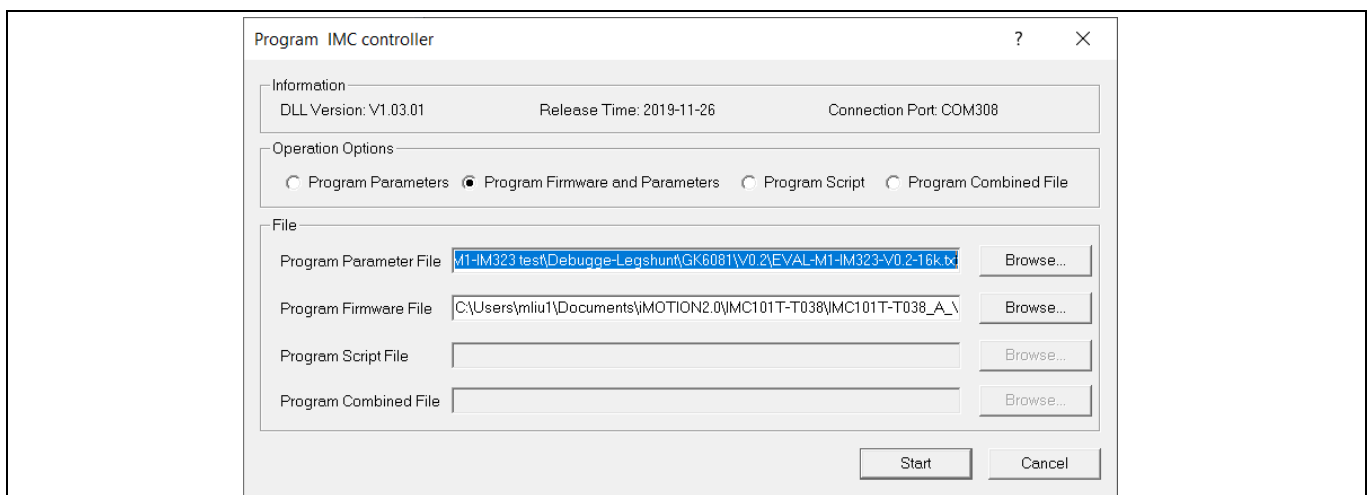
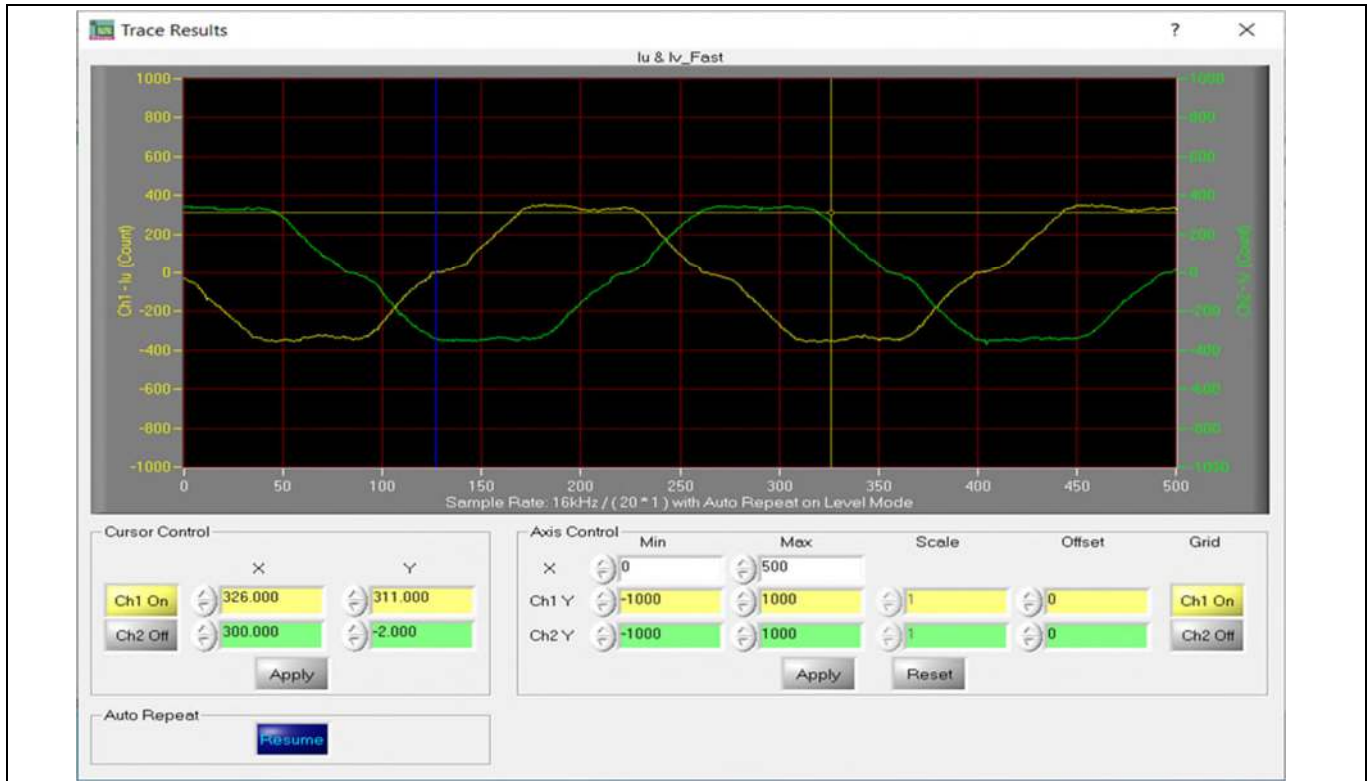

**Figure 9 MCEDesigner’s program page**

- 10. Double-click the **VF Diagnostic** function in the motor1 page and monitor the motor current with an oscilloscope. If the motor current is not sinusoidal, change the target speed and Vd\_Ext in VF Diagnostic sub-function, then double-click **VF Diagnostic** again. Repeat until the oscilloscope shows a steady sinusoidal current with an amplitude that is 30–50% of the motor rate current.
- 11. Open System Page > Monitor Definitions and double-click **I<sub>u</sub> & I<sub>v</sub> Slow**. The motor current feedback should be clean and sinusoidal, as shown in Figure 10. If not, please tune the Gating Propagation Delay & Phase Shift Window Size in the MCEWizard. The sampled motor-current noise amplitude should be less than 50–100 counts (below 5% of the motor current or below 5% of the maximum AD (Analog to Digital converter) range, which is 2048 counts.) If not, the motor current sample-related hardware and the setup need tuning. The VF Diagnostic sub-function can verify whether the:
  - Motor is correctly connected
  - IGBT/MOS and gate driver work as expected
  - Parameters related to current-sensing are correctly configured

- PCB layout and DC bus decoupling has been done correctly

12. After the VF Diagnostic is complete, click **STOP** (the red traffic light button) to stop the PWM (Pulse Width Modulation).



**Figure 10 Trace waveform for  $I_u$  &  $I_v$  open loop diagnostic**

13. Click the green traffic light button in the control bar to start the motor or double-click **Start Motor** sub-function in the Motor1 page - group of User Application Function Definitions; motor runs when the above step functions properly.
14. Check the motor-spin direction, adjust the UVW connection order, or set negative target speed in the MCEDesigner if the direction is wrong.
15. Set the target speed to about 50% of the maximum speed and start the  $I_u$  &  $Flx\_M$  trace with Auto Repeat on Level Mode (see Figure 11.)  $Flx\_M$  is better within the range of 2000 to 2500 (rated value is 2048), and must be steady and DC-like.

Some key tips for better motor-performance tuning are:

- If  $Flx\_M$  is not steady (i.e. swinging or oscillating), double check the motor parameters, speed loop Proportional-Intergral (PI) gain, flux estimator time constant, and the setup related to the PLL PI bandwidth (parameters  $PLLKp$  and  $PLLKi$ )
- If  $Flx\_M$  is noisy, double check the current feedback, and the hardware and parameters related to  $V_{DC}$
- If  $Flx\_M$  is far from 2048, adjust the Motor Back EMF Constant ( $K_e$ ) in the MCEWizard



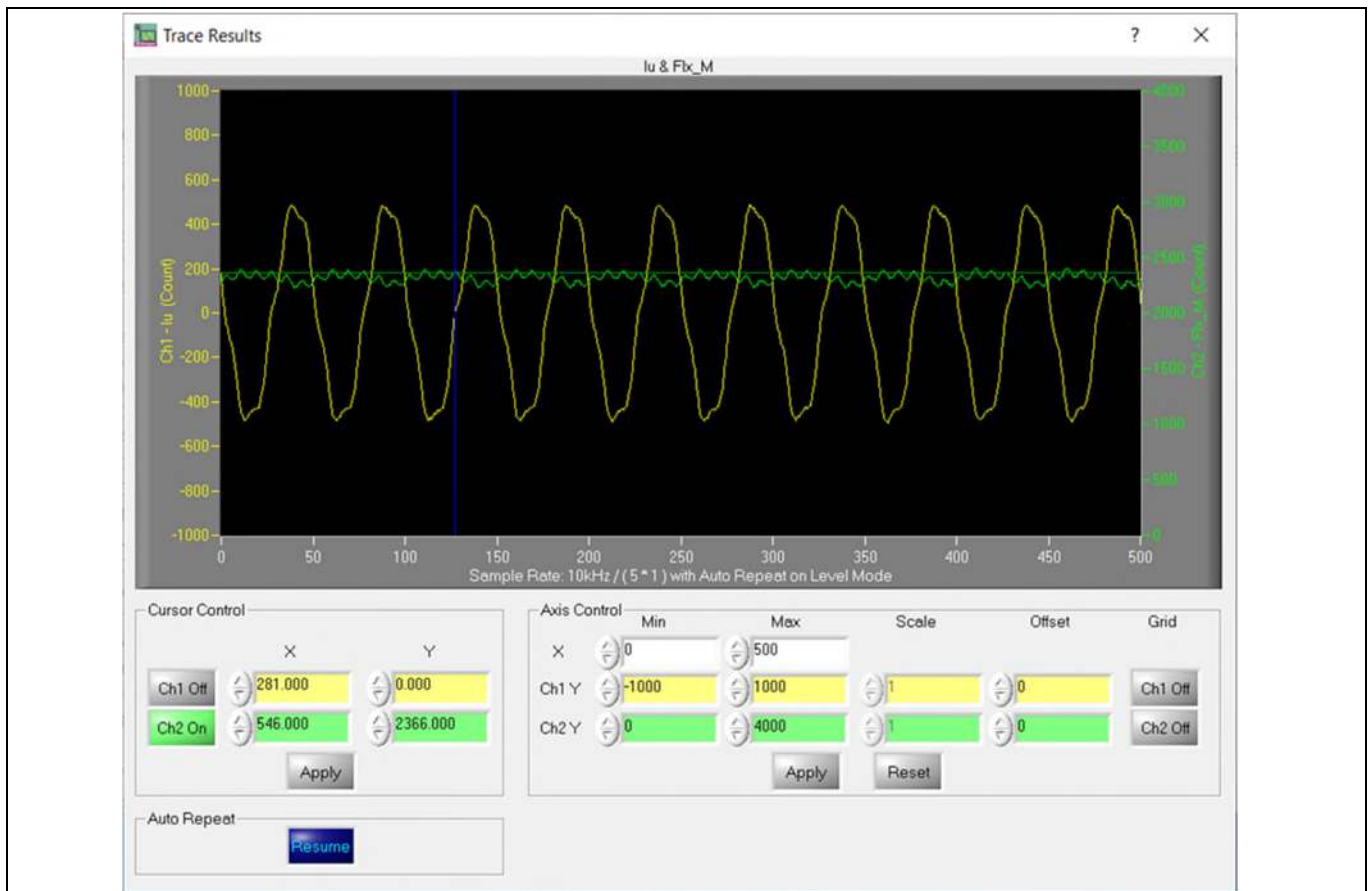

**Figure 11 Trace waveform for  $I_u$  &  $Flx$ -M at 50% speed**

16. To program a new parameter file after the firmware has been programmed, follow the instructions given in step 9. In such cases, firmware programming is not needed and the first option—Program Parameters can be selected.

*Note: For detailed information on controller programming, refer to the Application Note AN2018-33 iMOTION™ 2.0 Device Programming, and the documentation for the MCEDesigner and MCEWizard.*

## 2.2 Description of functional blocks

The motor inverter in the EVAL-M1-IM323 evaluation design is implemented using the CIPOS™ Tiny IPM IM323-L6Gx, and the auxiliary power supply is based on the fixed-frequency CoolSET™ ICE5AR4770BZS.

### 2.2.1 Overview of IM323-L6Gx

The CIPOS™ Tiny IPM IM323 product group enables the integration of various power and control components to increase reliability, optimize PCB size, and reduce system costs. It is designed to control 3-phase AC motors and permanent-magnet motors in variable speed drives for applications such as air conditioners and refrigerators.

The package concept is especially adapted to power applications that need good thermal conduction, electrical isolation, EMI-save control, and overload protection. The integrated reverse-conducting IGBTs are combined with an optimized silicon on insulator (SOI) gate driver for excellent electrical performance.

Figure 12 shows the internal block diagram of the CIPOS™ Tiny IPM IM323-L6Gx.

# EVAL-M1-IM323 user guide

## iMotion™ modular application design kit

### System and functional description

Its main features include:

- A 600 V reverse conducting, RCD2 IGBT
- A rugged SOI gate driver technology with stability against transient and negative voltage
- An allowable negative  $V_s$  potential up to -11 V for signal transmission at  $V_{BS} = 15$  V
- An integrated bootstrap functionality
- An overcurrent shutdown mechanism
- A built-in NTC thermistor for temperature monitoring
- Undervoltage lockout at all channels
- Low-side emitter pins accessible for phase current monitoring (open emitter)
- A sleep function
- Cross-conduction prevention
- All six switches turn off during protection

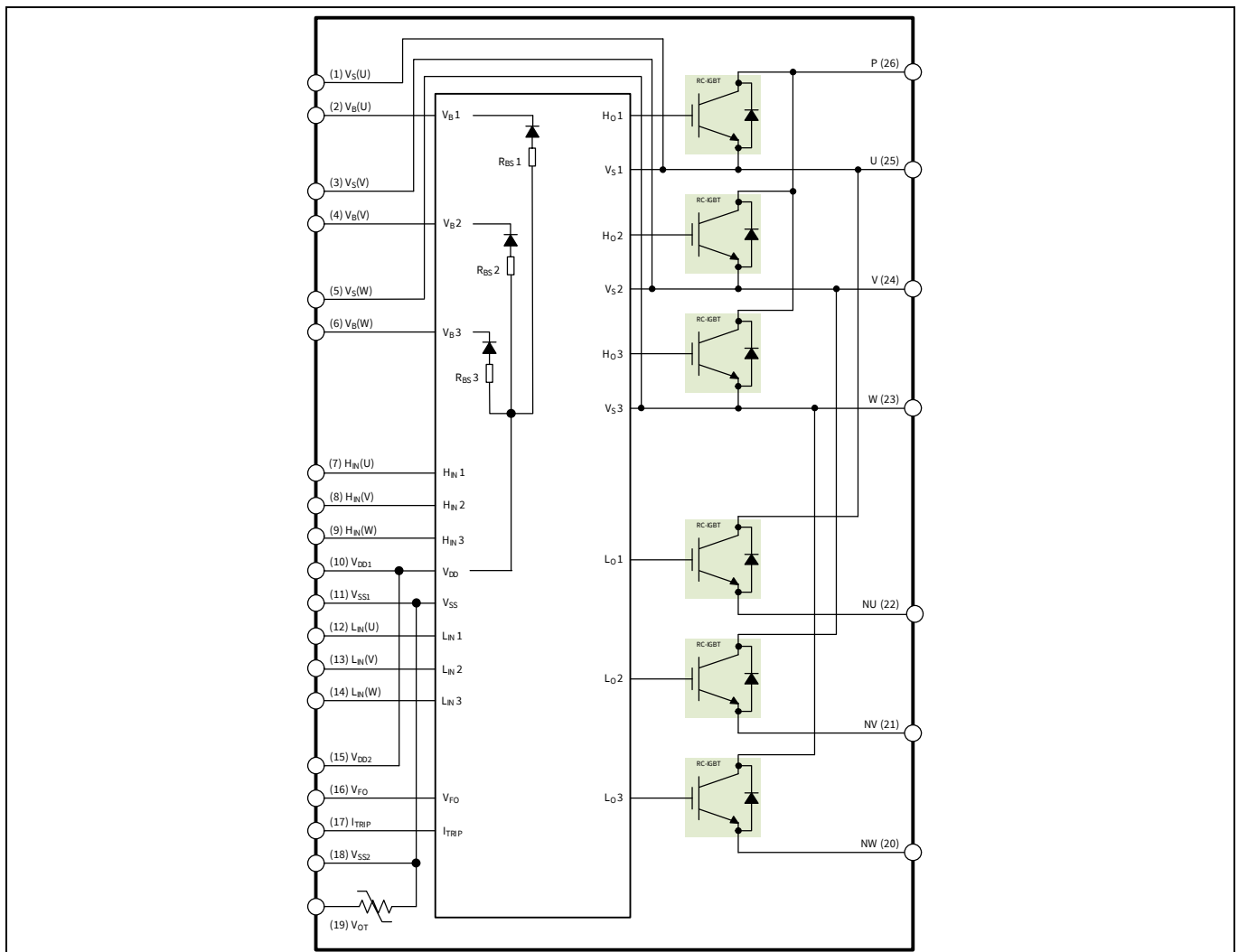
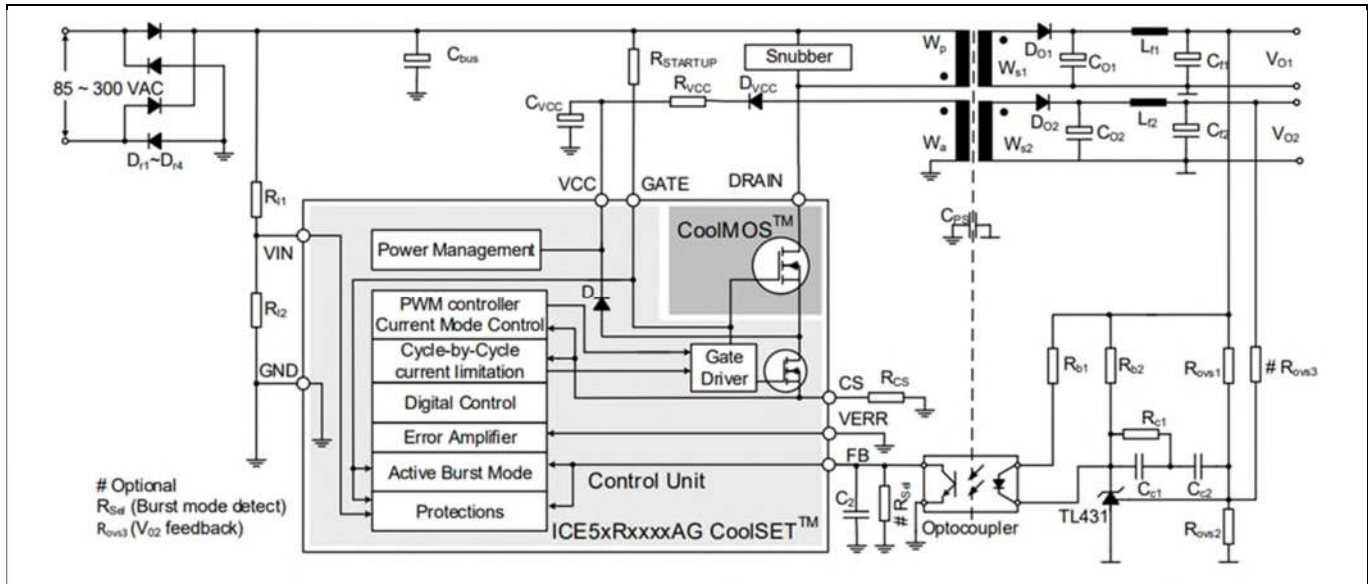

**Figure 12** Internal block of the IM323-L6Gx

### 2.2.2 Overview of ICE5AR4770BZS

The ICE5AR4770BZS is a 5<sup>th</sup> generation, fixed-frequency integrated power IC (CoolSET™) that offers high performance and integration with the 700 V avalanche rugged CoolMOS™ MOSFET technology controller chip in a PG-DIP-7 package.

Figure 13 shows its internal block diagram and typical isolated flyback application.



**Figure 13 Internal block of ICE5AR4770BZS and typical application in an isolated flyback mode**

Main features of the ICE5AR4770BZS include:

- A maximum switching frequency of 100 kHz with a 700 V integrated MOSFET
- Power delivery of up to 15 W with a universal wide input range (85 - 300 V<sub>AC</sub>) DCM design
- Brown-in protection, fast and robust start-up operation with cascode configuration
- 3-level selectable entry/exit active-burst mode profile (optional)
- A built-in digital soft start
- Cycle-by-cycle peak current limitation
- Support for both DCM and CCM operations with slope compensation
- An integrated error amplifier to support direct feedback, typically with non-isolated flyback topology
- Digital frequency reduction with decreased load for higher efficiency
- Frequency jitters and soft gate driving for low EMI
- Limited charging current for the V<sub>CC</sub> pin short-to-ground
- Comprehensive protection against V<sub>CC</sub> overvoltage, V<sub>CC</sub> undervoltage, overload/open loop, and overtemperature
- Auto-restart for all protection features

### 2.2.3 Motor external current feedback configuration and calculation

As shown in Figure 14, the current input value is a product of the shunt resistance in milliohms and the gain of the external current-sense amplifier of the EVAL-M1-101T.

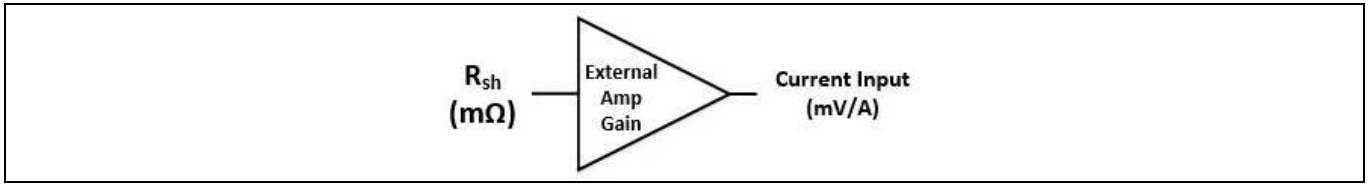

**Figure 14** Current shunt feedback and sample timing for EVAL-M1-101T

The external gain-amplifier circuit can be found in the schematics or user manual for the control board (e.g. EVAL-M1-101T.)

Figure 15 shows the  $I_{U+}$  current feedback-sensing circuitry on the EVAL-M1-101T evaluation board. Please note that the default external amplification gain is less than 1 for the current-sense in this evaluation board.

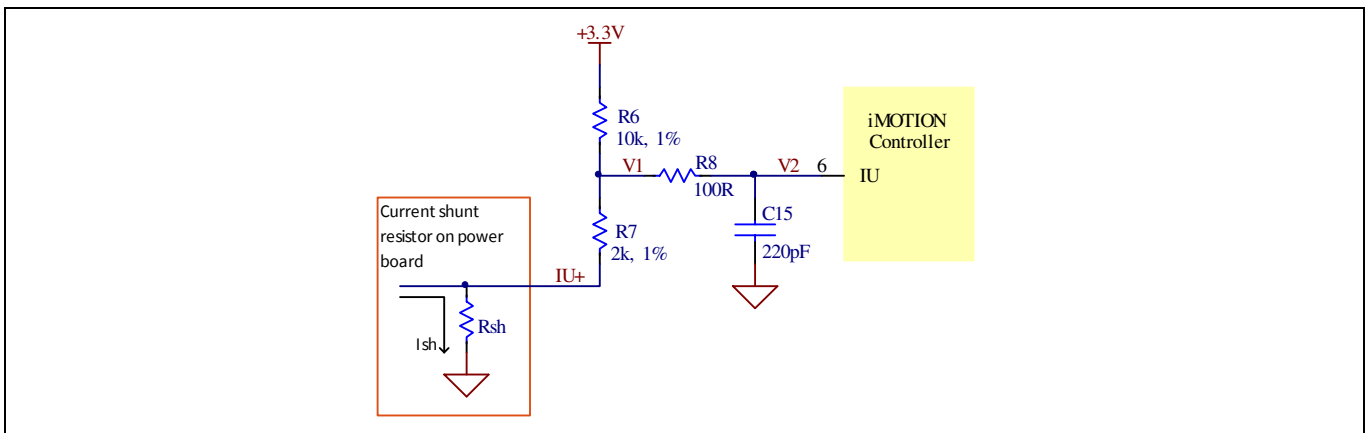

**Figure 15**  $I_{U+}$  current feedback-sensing circuitry on the EVAL-M1-101T evaluation board

Based on the principle of Kirchhoff's voltage law:

$$V_2 \approx V_1 \approx (V_{DD} - I_{sh} * R_{sh}) * \frac{R_7}{R_6 + R_7} + I_{sh} * R_{sh} = \frac{R_7}{R_6 + R_7} V_{DD} + \frac{R_6}{R_6 + R_7} R_{sh} * I_{sh}$$

$$current\ input = \frac{R_6}{R_6 + R_7} R_{sh} = \frac{5}{6} R_{sh}$$

Based on this calculation, the current input for the MADK combination in EVAL-M1-101T and EVAL-M1-IM323 is 25 mV/A.

**System design**

### 3 System design

The EVAL-M1-IM323 board is an optimized design for 220 V small home appliances like conditioner, pump, and fan applications. To meet individual customer requirements, and to make the EVAL-M1-IM323 evaluation design a basis for development or modification, all board design data such as schematics, Gerber, and AD files can be found on Infineon’s website.

#### 3.1.1 EMI filter and soft power-up circuit

Figure 16 shows the schematic from the AC input connector X1 to the rectified DC bus voltage. This circuitry includes a passive EMI filter consisting of elements X2, Y2 capacitors and common-mode inductor, a 35 A/800 V rectifier bridge D1, a fuse F1 for circuit protection, a PTC resistor R1, and a relay K1 for soft powering up and reducing conduction losses in the steady state.

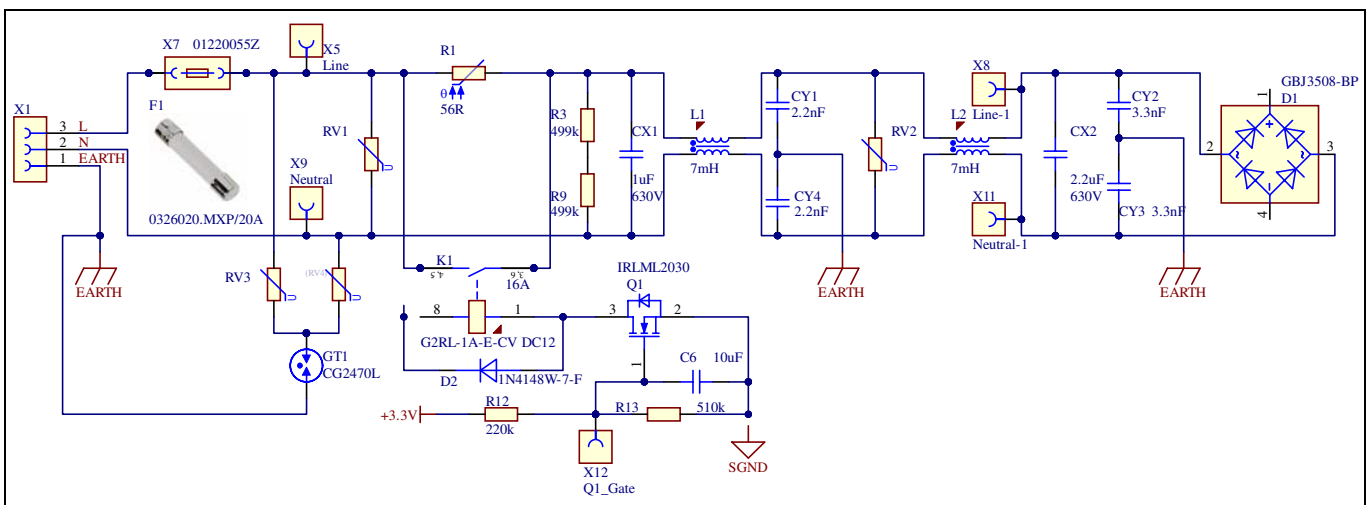

**Figure 16 Schematics for EMI filter and a soft power-up circuit**

#### 3.1.2 Inverter section using CIPOS™ Tiny IPM

The inverter section is implemented using the CIPOS™ Tiny IPM as shown in Figure 17. The module includes a combination of an optimized reverse-conducting IGBT Gen 2 (RCD2), and industry-benchmark rugged half-bridge drivers. The shunt resistor section is also given in the inverter section, including the 0 Ω resistors R46 and R47. These resistors allow leg shunt or single shunt through different combinations. The three capacitors C7, C13, and C15 are used as bootstrap capacitors to provide the necessary floating supply voltages VBS1, VBS2, and VBS3 respectively.

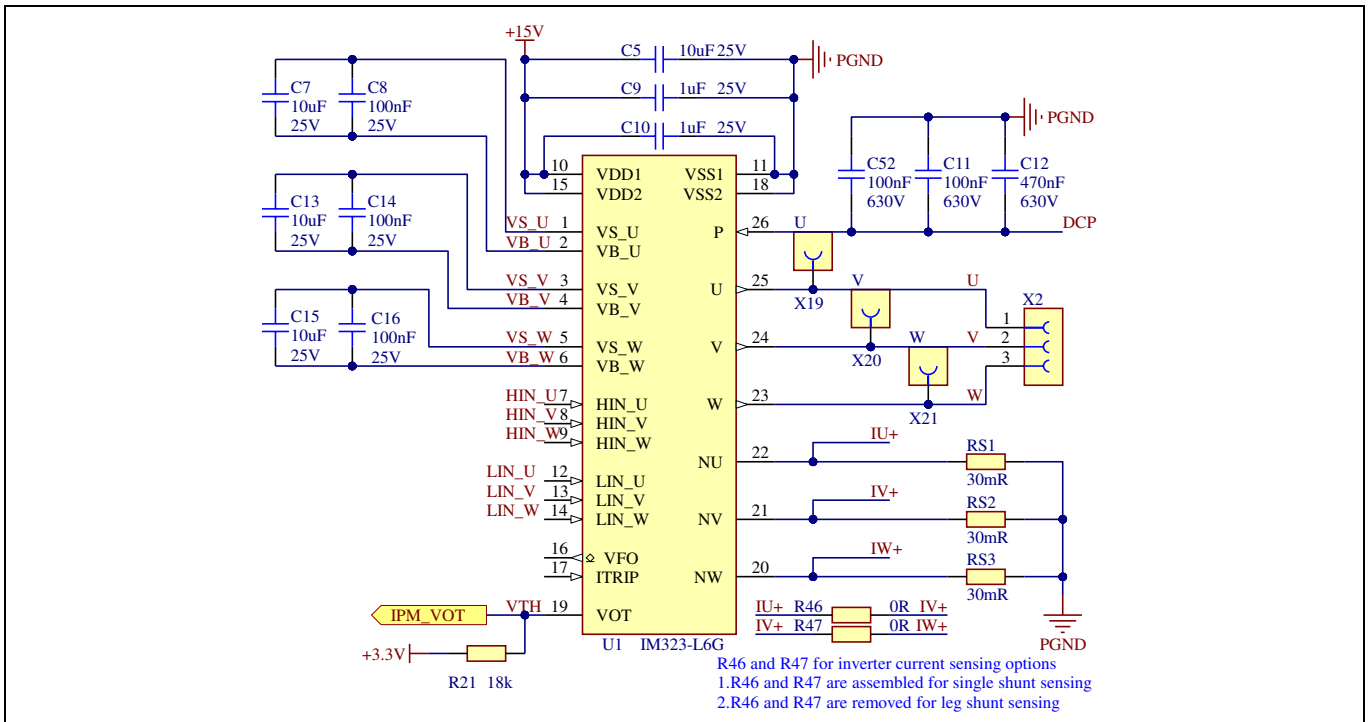

**Figure 17 Schematics for the IM323-L6Gx IPM and peripheral circuit**

### 3.1.3 Auxiliary power supply

Figure 18 shows the schematic of the auxiliary power supply for the EVAL-M1-IM323 board. The circuit includes the latest CoolSET™ 5 (ICE5AR4770BZS) from Infineon and a flyback topology with direct output of 15 V and 7 V. The VCC is connected to the gate drivers inside the CIPOS™ IPM.

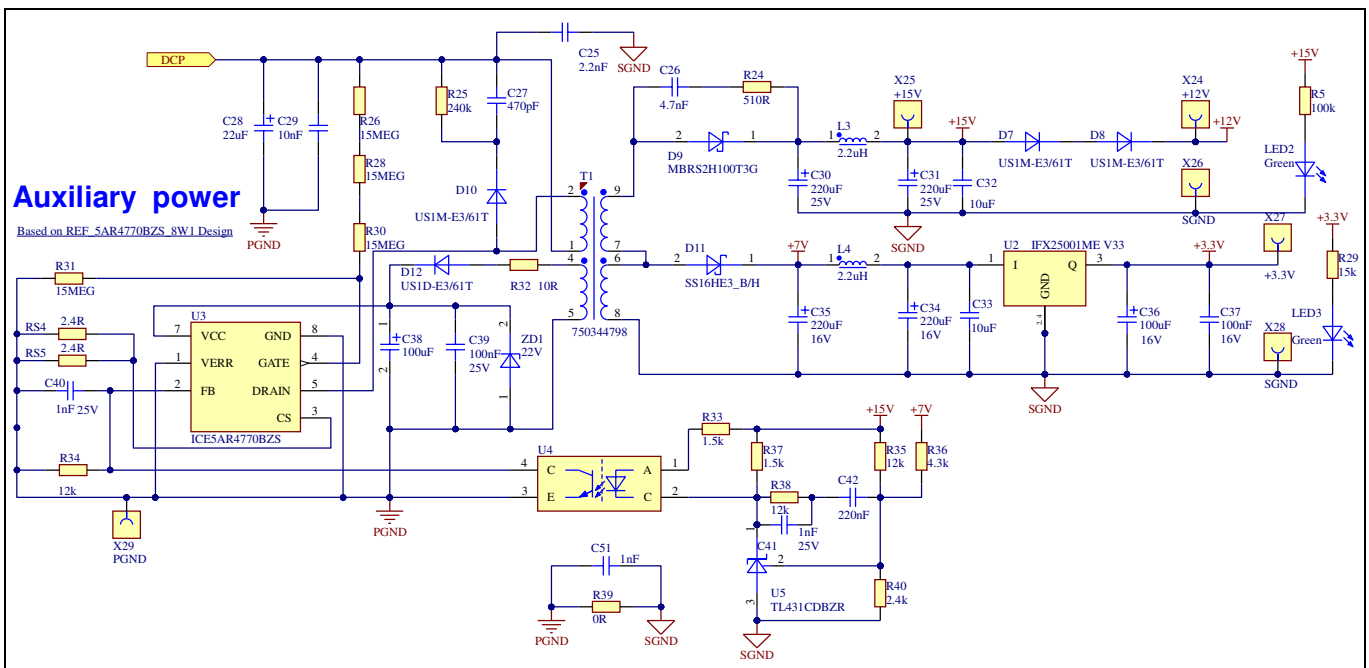

**Figure 18 Auxiliary power supply of the EVAL-M1-IM323**



# EVAL-M1-IM323 user guide

## iMotion™ modular application design kit

### System design

The linear voltage regulator IFX25001ME V33 generates 3.3 V from a 7 V power supply VCC. The 3.3 V power supply is used in the inverter’s external overcurrent comparator circuit. Both VCC and 3.3 V are also present on the 20-pin iMOTION™ MADK-M1 interface connector X3 to power the circuitry on the control board.

### 3.2 Layout

The EVAL-M1-IM323 board has two electrical layers with 140 μm copper (1 oz. copper) and dimension 180 mm x 140 mm. The thickness of the PCB board is 1.6 mm. Figure 19 to 22 shows the assembly prints and layers of the EVAL-M1-IM323.

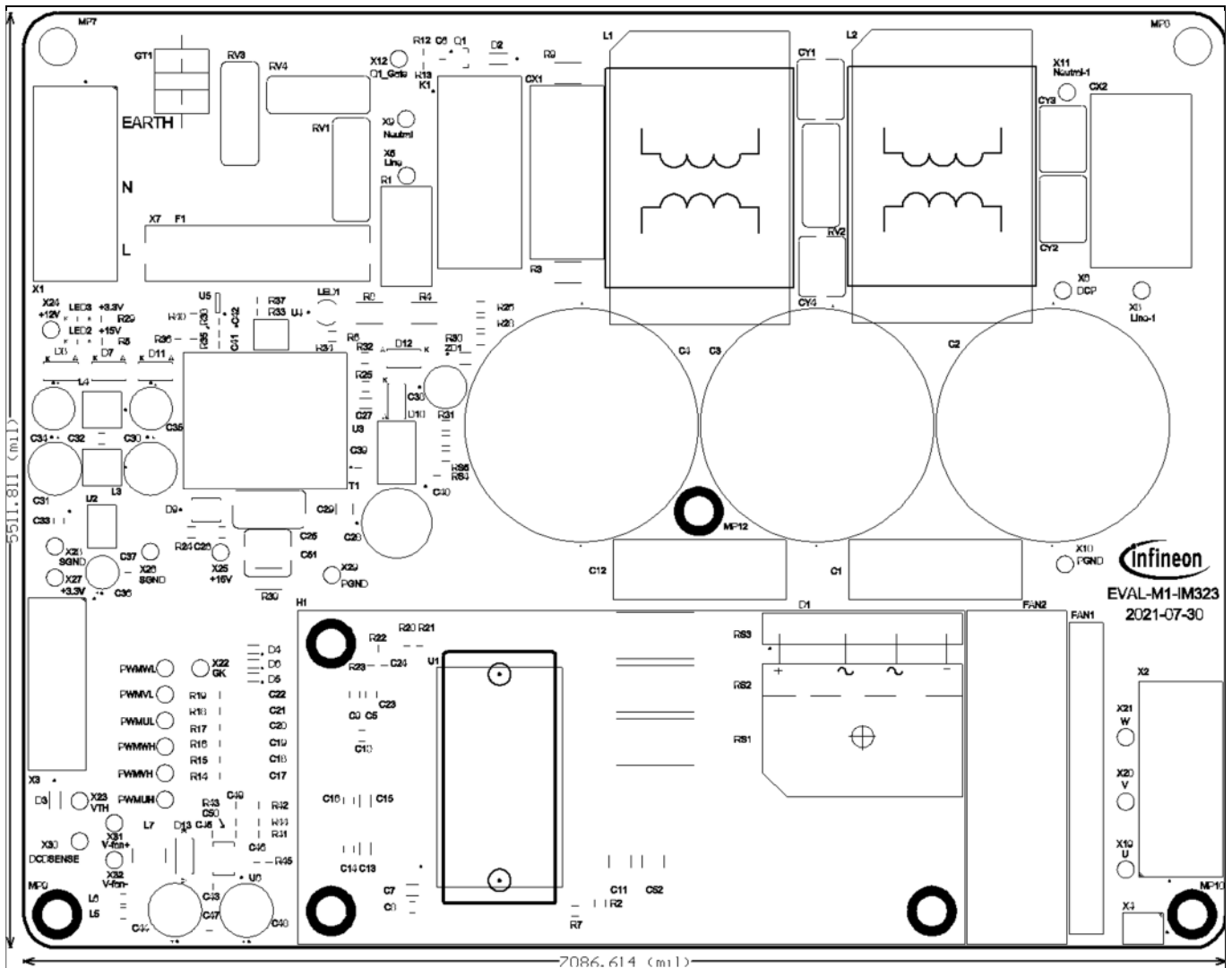
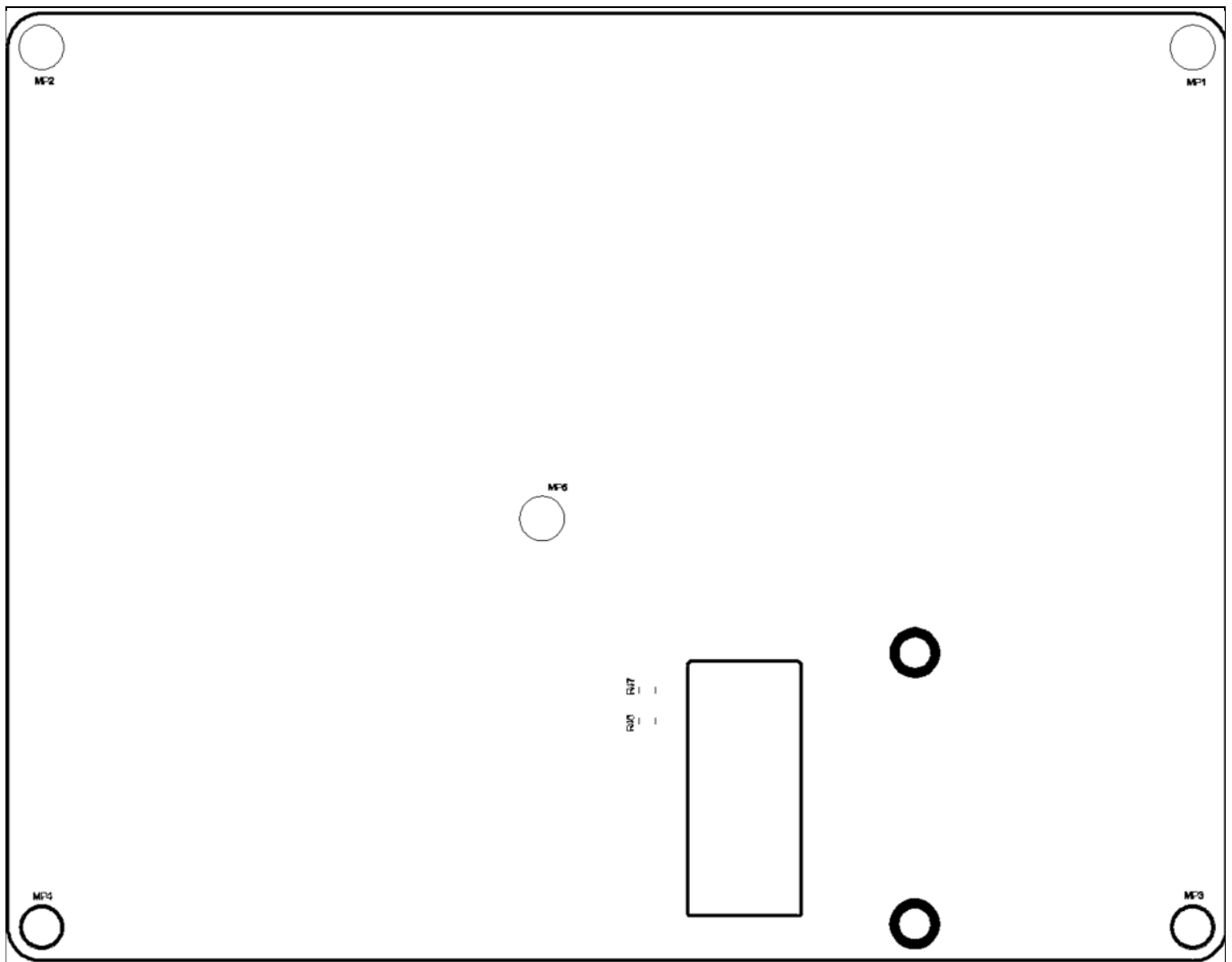

Figure 19 Top-assembly print of the EVAL-M1-IM323



**Figure 20** Bottom-assembly print of the EVAL-M1-IM323

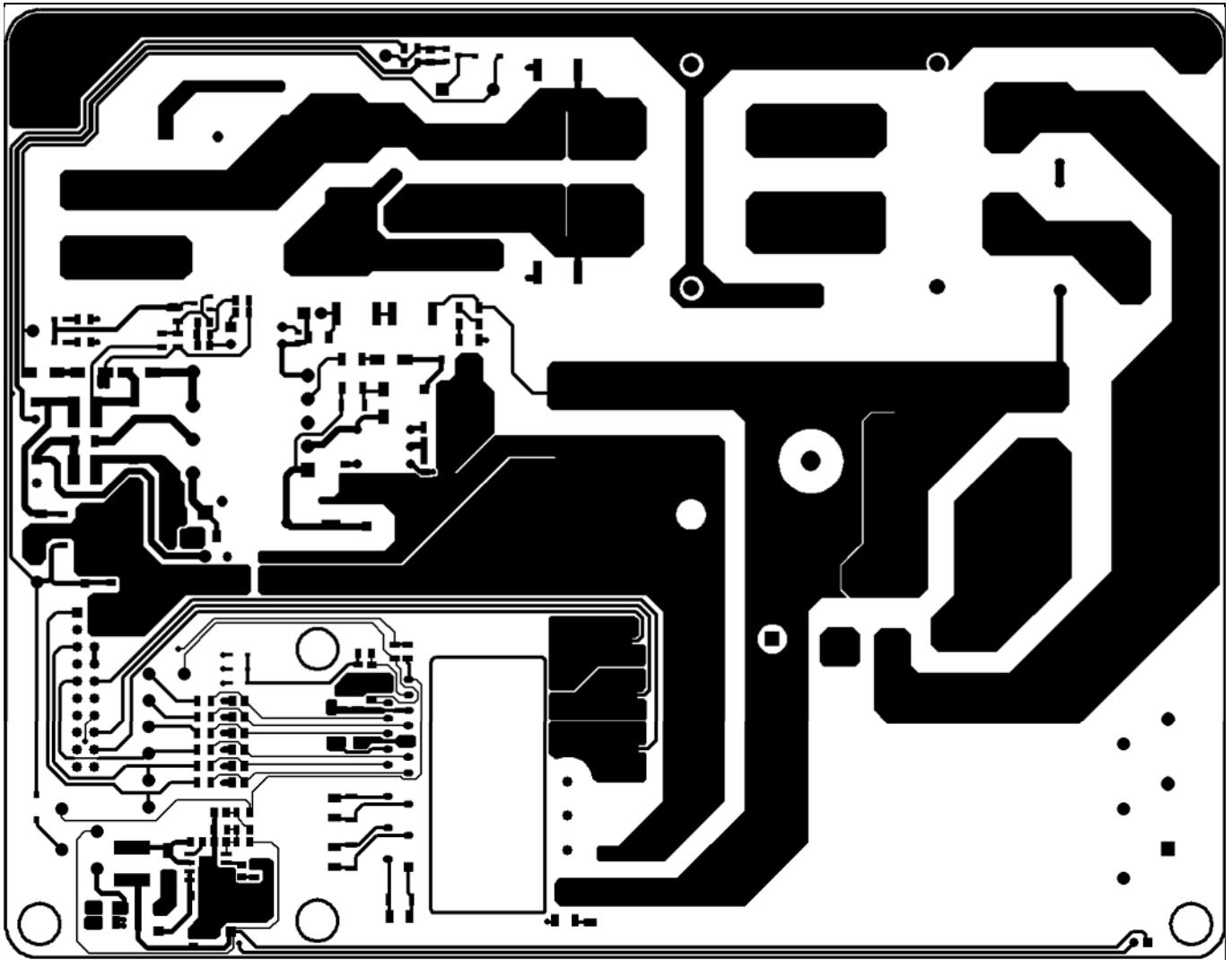

Figure 21 Top layer of the EVAL-M1-IM323

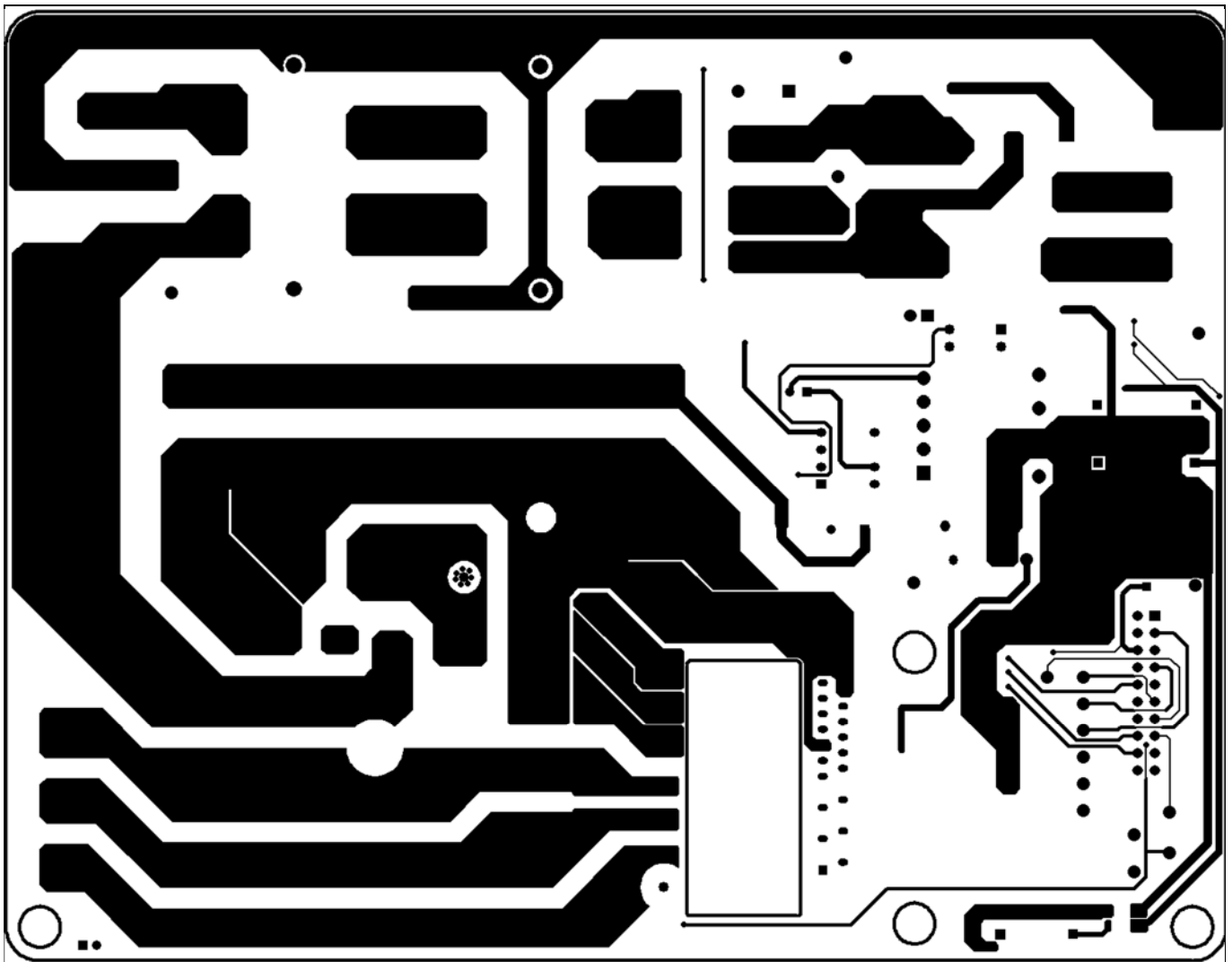

Figure 22 Bottom layer of the EVAL-M1-IM323

### 3.3 Bill of material

The complete bill of material can be downloaded (a customer login is required) from the Download section on the homepage of Infineon’s website.

Table 3 BOM of the most important/critical parts of the evaluation board

S. No.	Ref Designator	Description	Manufacturer	Manufacturer P/N
1	C1, C12	CAP / FILM / 470nF / 630 V / 10% / MKT (Metallized Polyester) / -40°C to 85°C / 22.50 mm C x 0.80 mm W 26.00 mm L X 9.00 mm T X 19.00 mm H / THT / -	Würth Elektronik	890303426008CS
2	C2, C3, C4	CAP / ELCO / 680 µF / 450 V / 20% / Aluminium electrolytic / -25°C to 105°C / 10.00 mm Pitch x 35.00 mm Dia x 59.00 mm H / - / -	Würth Elektronik	861141486026

**System design**

S. No.	Ref Designator	Description	Manufacturer	Manufacturer P/N
3	C5	CAP / CERA / 10 µF / 25 V / 10% / X5R (EIA) / -55°C to 85°C / 1206(3216) / SMD / -	MuRata	GRM31CR61E106KA12
4	C6	CAP / CERA / 10 µF / 16 V / 10% / X5R (EIA) / -55°C to 85°C / 0805(2012) / SMD / -	MuRata	GRM21BR61C106KE15
5	C7, C13, C15	CAP / CERA / 10 µF / 25 V / 10% / X7R (EIA) / -55°C to 125°C / 1206 (3216) / SMD / -	Würth Elektronik	885012208069
6	C8, C14, C16	CAP / CERA / 100 nF / 25 V / 10% / X7R (EIA) / -55°C to 125°C / 1206(3216) / SMD / -	MuRata	GRM319R71E104KA01
7	C9, C10	CAP / CERA / 1 µF / 25 V / 5% / X7R (EIA) / -55°C to 125°C / 1206(3216) / SMD / -	MuRata	GCM31MR71E105JA37
8	C11, C52	CAP / CERA / 100 nF / 630 V / 10% / X7R (EIA) / -55°C to 125°C / 1812 / SMD / -	Würth Elektronik	885342211006
9	C17, C18, C19, C20, C21, C22	CAP / - / 1 nF / 16 V / 10% / X7R (EIA) / - / 0805 / SMD / -	AVX	0805YC102K4T2A
10	C23	CAP / CERA / 1 nF / 25 V / 5% / - / -55°C to 125°C / 0805 (2012) / SMD / -	Würth Elektronik	885012007040
11	C24, C46	CAP / CERA / 22 nF / 25 V / 5% / X7R (EIA) / -55°C to 125°C / 0805(2012) / SMD / -	MuRata	GRM216R71E223JA01
12	C25	CAP / CERA / 2.2 nF / 760 V / 20% / Y5U (EIA) / -30°C to 125°C / 9.50 mm C x 0.81 mm W 10.90 mm L x 5.70 mm T x 14.10 mm H / - / -	Vishay	440LD22-R
13	C26	CAP / CERA / 4.7 nF / 100 V / 5% / C0G (EIA) / NP0 / -55°C to 125°C / 1206(3216) / SMD / -	MuRata	GRM3195C2A472JA01
14	C27	CAP / CERA / 470 pF / 630 V / 5% / C0G (EIA) / NP0 / -55°C to 125°C / 1206(3216) / SMD / -	MuRata	GRM31A5C2J471JW01
15	C28	CAP / ELCO / 22 µF / 400 V / 20% / Aluminium electrolytic / -25°C to 105°C / 5.00 mm C x 0.60 mm W 10.50 mm Dia x 18.00 mm H / - / -	-	EHS2GM220G160T
16	C29	Chip Monolithic Ceramic Capacitor	MuRata	GCM32D7U2J103JX01
17	C30, C31, C44, C48	CAP / ELCO / 220 µF / 25 V / 20% / Aluminium electrolytic / -40°C to	Würth Elektronik	860020474012

**System design**

S. No.	Ref Designator	Description	Manufacturer	Manufacturer P/N
		105°C / 3.50 mm C x 0.60 mm W 8.00 mm Dia x 13.00 mm H / - / -		
18	C32, C33	Chip Monolithic Ceramic Capacitor	MuRata	GRM31CR71E106MA12
19	C34, C35	CAP / ELCO / 220 µF / 16 V / 20% / Aluminium electrolytic / -40°C to 85°C / 2.50 mm C x 0.50 mm W 6.30 mm Dia x 12.50 mm H / THT / -	Würth Elektronik	860010373010
20	C36	CAP / ELCO / 100 µF / 16 V / 20% / Aluminium electrolytic / -40°C to 85°C / 2.00 mm C x 0.50 mm W 5.00 mm Dia x 12.50 mm H / THT / -	Würth Elektronik	860010372006
21	C37	CAP / CERA / 100 nF / 16 V / 20% / X7R (EIA) / -55°C to 125°C / 0805(2012) / SMD / -	MuRata	GRM21BR71C104MA01
22	C38	CAP / ELCO / 100 µF / 35 V / 20% / Aluminium electrolytic / -40°C to 85°C / 2.50 mm C x 0.50 mm W 6.30 mm Dia x 12.50 mm H / - / -	Würth Elektronik	860010573007
23	C39	Chip Monolithic Ceramic Capacitor	MuRata	GRM21BR71E104KA01
24	C40, C41	Chip Monolithic Ceramic Capacitor	MuRata	GRM216R71E102KA01
25	C42, C45, C47, C50	CAP / CERA / 220 nF / 25 V / 5% / X7R (EIA) / -55°C to 125°C / 0805(2012) / SMD / -	MuRata	GRM219R71E224JA01
26	C43	CAP / CERA / 100 nF / 25 V / 10% / X7R (EIA) / -55°C to 125°C / 0805(2012) / SMD / -	MuRata	GRM219R71E104KA01
27	C49	CAP / CERA / 100 nF / 25 V / 5% / X7R (EIA) / -55°C to 125°C / 0805(2012) / SMD / -	MuRata	GRM21BR71E104JA01
28	C51	CAP / CERA / 1 nF / / 20% / E (JIS) / -40°C to 125°C / 7.50 mm C x 0.60 mm W 7.00 mm L x 7.00 mm T x 10.00 mm H / THT / -	MuRata	DE6E3KJ102MN3A
29	CX1	CAP / FILM / 1 µF / 630 V / 10% / MKP (Metallized Polypropylene) / -40°C to 105°C / 22.50 mm C x 0.80 mm W 26.00 mm L x 11.00 mm T x 20.50 mm H / - / -	Würth Elektronik	890334026027CS
30	CX2	CAP / FILM / 2.2 µF / 630 V / 10% / MKP (Metallized Polypropylene) / -40°C to 105°C / 22.50 mm C x	Würth Elektronik	890334026034CS



**System design**

S. No.	Ref Designator	Description	Manufacturer	Manufacturer P/N
		0.80 mm W 26.00 mm L x 15.00 mm T x 25.50 mm H / - / -		
31	CY1, CY4	CAP / CERA / 2.2 nF / / 20% / - / - 40°C to 125°C / 7.50 mm C x 0.60 mm W 9.00 mm L x 7.00 mm T x 12.00 mm H / - / -	MuRata	DE6E3KJ222MN3A
32	CY2, CY3	CAP / CERA / 3.3 nF / / 20% / E (JIS) / -40°C to 125°C / 7.50 mm C x 0.60 mm W 10.00 mm L x 7.00 mm T x 13.00 mm H / THT / -	MuRata	DE6E3KJ332MN3A
33	D1	35 Amp Glass Passivated Bridge Rectifier, 800 V	Micro Commercial Components	GBJ3508-BP
34	D2, D3	Surface Mount Fast Switching Diode	Diodes Incorporated	1N4148W-7-F
35	D4, D5, D6	Silicon Schottky Diode	Infineon Technologies	BAT60A
36	D7, D8, D10	Surface Mount Ultrafast Rectifier 1.0 A/1000 V	Vishay	US1M-E3/61T
37	D9	2.0 A/100 V, Surface Mount Schottky Power Rectifier	ON Semiconductor	MBRS2H100T3G
38	D11, D13	Surface Mount Schottky Barrier Rectifier, 60 V	Vishay	SS16HE3_B/H
39	D12	Surface Mount Ultrafast Rectifier 1.0 A/200 V	Vishay	US1D-E3/61T
40	F1	250 V <sub>AC</sub> /V <sub>DC</sub> , 20 A rated, Fuse with ceramic body construction permits higher interrupting ratings and voltage ratings. Ideal for applications where high current loads are expected.	Littelfuse	326020.MXP
41	FAN1	Fan Guard, for 50 mm Fan, 40 mm pitch	CUI	FG50-40
42	FAN2	DC Axial Fan for omniCOOL bearing system, 50 mm x 50 mm frame. Multiple Speed options	CUI	CFM-5015V-138-201
43	GT1	Gas Discharge Tubes - GDTs / Gas Plasma Arrestors STANDARD 470 V NOM	Littelfuse	CG2470L
44	H1	Standard Heat sink	Infineon Technologies	HS-5050-100
45	K1	Relay, 1 Pole, Normally Open 3, 6 to 4, 5, 6 Pins	Omron	G2RL-1A-E-CV DC12
46	L1, L2	IND / STD / 7 mH / 15 A / 50% / - 40°C to 125°C / 9.5 mR / THT / Inductor, THT; 10.00 mm pitch, 4	Würth Elektronik	7448061507

**System design**

S. No.	Ref Designator	Description	Manufacturer	Manufacturer P/N
		pin, 27.00 mm W x 46.00 mm L x 46.00 mm H body / THT / -		
47	L3, L4	IND / STD / 2.2 $\mu$ H / 2.5 A / 20% / -40°C to 125°C / 71 mR / SMD / Inductor, SMD; 2-Leads, 4.50 mm L x 4 mm W x 3.50 mm H body / SMD / -	Würth Elektronik	744773022
48	L5, L6	WE-CBF SMD EMI Suppression Ferrite Bead	Würth Elektronik	742792118
49	L7	For Choke	MuRata	LQH55DN101M03
50	LED1	LED 3 mm Red Through Hole Lamp	LiteOn Optoelectronics	LTL-1CHEE
51	LED2, LED3	WL-SMCW SMT Mono-color Chip LED Waterclear, Green, 515 nm	Würth Elektronik	150060GS75000
52	MP1, MP2, MP3, MP4, MP5	M3 Hexagonal Threaded Spacer, Length 11 mm	Harwin	R30-1611100
53	MP7, MP8, MP9, MP10, MP12	M3 x 6 mm Pan Head, Cross Head Metric Screw, 5.6 mm x 2.4 mm Head, Nylon 6,6	Duratool	D00687
54	Q1	30 V 154 mOhm@4.5 V MOSFET	Infineon Technologies	IRLML2030TRPbF
55	R1	PTC thermistor for overcurrent protection and as inrush current limiters	TDK Corporation	B59451C1130B070
56	R2, R7	RES / STD / 1MEG / 250 mW / 1% / 100 ppm/K / -55°C to 155°C / 1206 / SMD / -	Vishay	CRCW12061M00FK
57	R3, R4, R8, R9	RES / STD / 499 k / 1 W / 1% / 100 ppm/K / -55°C to 155°C / 2512 / SMD / -	Vishay	CRCW2512499KFK
58	R5, R42, R44	RES / STD / 100 k / 125 mW / 1% / 100 ppm/K / -55°C to 155°C / 0805 / SMD / -	Vishay	CRCW0805100KFK
59	R6	RES / STD / 51k / 250mW / 1% / 100ppm/K / -55°C to 155°C / 1206 / SMD / -	Vishay	CRCW120651K0FK
60	R12	RES / STD / 220 k / 125 mW / 1% / 100 ppm/K / -55°C to 155°C / 0805 / SMD / -	Vishay	CRCW0805220KFK
61	R14, R15, R16, R17, R18, R19, R22	RES / STD / 100 R / 125 mW / 1% / 100 ppm/K / -55°C to 155°C / 0805 / SMD / -	Vishay	CRCW0805100RFK
62	R20	RES / STD / 4.7 k / 125 mW / 1% / 100 ppm/K / -55°C to 155°C / 0805 / SMD / -	Vishay	CRCW08054K70FK

**System design**

<b>S. No.</b>	<b>Ref Designator</b>	<b>Description</b>	<b>Manufacturer</b>	<b>Manufacturer P/N</b>
63	R21	RES / STD / 18 k / 125 mW / 1% / 100 ppm/K / -55°C to 155°C / 0805 / SMD / -	Vishay	CRCW080518K0FK
64	R23	RES / STD / 1 k / 125 mW / 1% / 100 ppm/K / -55°C to 155°C / 0805 / SMD / -	Vishay	CRCW08051K00FK
65	R24	RES / STD / 510 R / 250 mW / 1% / 100 ppm/K / -55°C to 155°C / 1206 / SMD / -	Vishay	CRCW1206510R0FK
66	R25	RES / STD / 240 k / 250 mW / 1% / 100 ppm/K / -55°C to 155°C / 1206 / SMD / -	Vishay	CRCW1206240K0FK
67	R26, R28, R30, R31	15M / 0.25 W / 5%	Yageo	RC1206JR-0715ML
68	R29	RES / STD / 15 k / 125 mW / 1% / 100 ppm/K / -55°C to 155°C / 0805 / SMD / -	Vishay	CRCW080515K0FK
69	R32	Standard Thick Film Chip Resistor	Vishay	CRCW120610R0FK
70	R33, R37	RES / STD / 1.5 k / 125 mW / 1% / 100 ppm/K / -55°C to 155°C / 0805 / SMD / -	Vishay	CRCW08051K50FK
71	R35, R38	RES / STD / 12 k / 125 mW / 1% / 100 ppm/K / -55°C to 155°C / 0805 / SMD / -	Vishay	CRCW080512K0FK
72	R39	RES / STD / 0R / - / 0R / - / -55°C to 155°C / 2512 / SMD / -	Vishay	CRCW25120000Z0
73	R40	RES / STD / 2.4 k / 125 mW / 1% / 100 ppm/K / -55°C to 155°C / 0805 / SMD / -	Vishay	CRCW08052K40FK
74	R41	RES / STD / 2MEG / 125 mW / 1% / 100 ppm/K / -55°C to 155°C / 0805 / SMD / -	Vishay	CRCW08052M00FK
75	R43	RES / STD / 62 k / 125 mW / 1% / 100 ppm/K / -55°C to 155°C / 0805 / SMD / -	Vishay	CRCW080562K0FK
76	R45	RES / STD / 22 k / 125 mW / 1% / 100 ppm/K / -55°C to 155°C / 0805 / SMD / -	Vishay	CRCW080522K0FK
77	RS1, RS2, RS3	RES / STD / 30 mR / 5 W / 1% / 75 ppm/K / -65°C to 275°C / 4527 / SMD / -	Vishay	WSR5R0300FEA
78	RS4, RS5	Standard Thick Film Chip Resistor	Vishay	CRCW12062R40FK

**System design**

S. No.	Ref Designator	Description	Manufacturer	Manufacturer P/N
79	RV1, RV2, RV3, RV4	RES / STD / - / 600 mW / - / - / - 40°C to 85°C / 7.50 mm C x 0.80 mm W 16.50 mm L x 7.00 mm T x 20.00 mm H / - / -	Würth Elektronik	820443011E
80	T1	Transformer, Turns Ratio (2-1):(9-7)-10:1, (2-1):(4-5)-5.71:1, (2-1):(6-8)-11.43:1, Dielectric-3000 V <sub>AC</sub>	Würth Elektronik	750344798
81	U1	CIPOS Tiny IM323	Infineon Technologies	IM323-L6G
82	U2	Low Dropout Voltage Regulator, 3.3 V Output	Infineon Technologies	IFX25001ME V33
83	U3	Fixed Frequency 700 V CoolSET	Infineon Technologies	ICE5AR4770BZS
84	U4	PLER, TRANSISTOR, 35 V, DIP-4	Würth Elektronik	140817140010
85	U5	Precision Programmable Reference	Texas Instruments	TL431CDBZR
86	U6	1.8 A DC/DC Step-Down Voltage Regulator, Adjustable Output Voltage	Infineon Technologies	IFX91041EJV
87	X1, X2	Horizontal Cable Entry Rising Cage Clamp WR-TBL,3 Pins	Würth Elektronik	691250910003
88	X3	WR-PHD 2.54 mm Angled Dual Socket Header	Würth Elektronik	613020243121
89	X4	Male Vertical Shrouded Header, 2 Pins, 2 mm Pitch	Würth Elektronik	62000211622
90	X5	Test Point THT, White	Keystone Electronics Corp.	5002
91	X6	Test Point THT, White	Keystone Electronics Corp.	5002
92	X7	Board Mount Fuse Clips for 1/4" Diameter Fuses	Littelfuse	01220055Z
93	X8	Test Point THT, White	Keystone Electronics Corp.	5002
94	X9	Test Point THT, White	Keystone Electronics Corp.	5002
95	X10, X29	Test Point THT, White	Keystone Electronics Corp.	5002
96	X11	Test Point THT, White	Keystone Electronics Corp.	5002
97	X12	Test Point THT, White	Keystone Electronics Corp.	5002
98	X13	Test Point THT, White	Keystone Electronics Corp.	5002

**System design**

<b>S. No.</b>	<b>Ref Designator</b>	<b>Description</b>	<b>Manufacturer</b>	<b>Manufacturer P/N</b>
99	X14	Test Point THT, White	Keystone Electronics Corp.	5002
100	X15	Test Point THT, White	Keystone Electronics Corp.	5002
101	X16	Test Point THT, White	Keystone Electronics Corp.	5002
102	X17	Test Point THT, White	Keystone Electronics Corp.	5002
103	X18	Test Point THT, White	Keystone Electronics Corp.	5002
104	X19	Test Point THT, White	Keystone Electronics Corp.	5002
105	X20	Test Point THT, White	Keystone Electronics Corp.	5002
106	X21	Test Point THT, White	Keystone Electronics Corp.	5002
107	X22	Test Point THT, White	Keystone Electronics Corp.	5002
108	X23	Test Point THT, White	Keystone Electronics Corp.	5002
109	X24	Test Point THT, White	Keystone Electronics Corp.	5002
110	X25	Test Point THT, White	Keystone Electronics Corp.	5002
111	X26, X28	Test Point THT, White	Keystone Electronics Corp.	5002
112	X27	Test Point THT, White	Keystone Electronics Corp.	5002
113	X30	Test Point THT, White	Keystone Electronics Corp.	5002
114	X31	Test Point THT, White	Keystone Electronics Corp.	5002
115	X32	Test Point THT, White	Keystone Electronics Corp.	5002
116	ZD1	Zener Diode with Surge Current Specification	Vishay	BZD27C22P-HE3-08

**3.4 Connector details**

General information on the connectors of the EVAL-M1-IM323 board’s evaluation design is provided in this section. Table 4 lists the details of the AC-input connector.

**System design**

**Table 4 AC input connector (X1)**

PIN	Label	Function
1	E	Earth ground
2	N	AC neutral input
3	L	AC line input

Table 5 lists the details of the motor UVW output connector X2.

**Table 5 Motor-side connector (X2)**

PIN	Label	Function
1	U	Connected to motor phase U
2	V	Connected to motor phase V
3	W	Connected to motor phase W

Table 6 lists the pin assignments of the 20-pin iMOTION™ MADK-M1 interface connector X3. This connector is the interface to the controller board.

**Table 6 X3 - iMOTION™ MADK-M1 20-pin interface connector for the controller board**

PIN	Label	Function
1	PWMUH	3.3 V-compatible logic input for high-side gate driver - Phase U
2	GND	Ground
3	PWMUL	3.3 V-compatible logic input for low-side gate driver - Phase U
4	GND	GND ground
5	PWMVH	3.3 V-compatible logic input for high-side gate driver - Phase V
6	+3.3 V	Onboard 3.3 V supply
7	PWMVL	3.3 V-compatible logic input for low-side gate driver - Phase V
8	+3.3 V	Onboard 3.3 V supply
9	PWMWH	3.3 V-compatible logic input for high-side gate driver - Phase W
10	I_U	Positive current sense output
11	PWMWL	3.3 V-compatible logic input for low-side gate driver - Phase W
12	I_U-	Negative current sense output or ground
13	GK	Gatekill signal – active low when overcurrent is detected
14	DCBSense	DC bus positive voltage, scaled in 0–3.3 V range by a voltage divider
15	VTH	Thermistor output
16	I_V	Not used
17	I_V-	Not used
18	I_W	Not used
19	I_W-	Not used
20	VCC	15 V power supply

### 3.5 Test points

Table 7 lists the assignments of the on-board test points.

**System design**

**Table 7 Test points for signal measurement**

<b>PIN</b>	<b>Label</b>	<b>Function</b>
X4	PWMUH	3.3 V-compatible logic input for high-side gate driver - Phase U
X5	PWMUL	3.3 V-compatible logic input for low-side gate driver - Phase U
X6	PWMVH	3.3 V-compatible logic input for high-side gate driver - Phase V
X7	PWMVL	3.3 V-compatible logic input for low-side gate driver - Phase V
X8	PWMWH	3.3 V-compatible logic input for high-side gate driver - Phase W
X9	PWMWL	3.3 V-compatible logic input for low-side gate driver - Phase W
X10	U	Inverter output, motor phase U
X11	V	Inverter output, motor phase V
X12	W	Inverter output, motor phase W
X13	DCP	DCP bus-voltage test point
X14	GND	GND test point
X15	15 V	15 V supply
X16	3.3 V	3.3 V supply
X17	SGND	SGND test point
X18	VTH	Test point for temperature sensing



## 4 System performance

### 4.1 Input voltage range test

**Table 8**      **Table 1**      **AC input voltage range**

<b>Specification</b>	165 V <sub>AC</sub> to 265 V <sub>AC</sub>
<b>Condition</b>	Typical PWM setup for a 6 kHz motor PWM, 3-phase only mode, motor speed = 1400 rpm, T <sub>A</sub> = 29°C, T <sub>C</sub> = 90°C
<b>Conclusion</b>	Input = 1500 W, P <sub>out</sub> = 1500 W, and I <sub>out</sub> = 7 A <sub>rms</sub> when input voltage is in the range of 165 to 265 V <sub>rms</sub>

#### Test Data

Input voltage (V <sub>rms</sub> )	Input current (A <sub>rms</sub> )	DCBUS (V)	Input power (W)	Power factor	Output power (W)	Output current (A <sub>rms</sub> )	Test waveform
165	12.59	208	1500	0.723	1400	7.788	Figure 23
220	10.56	296	1455	0.630	1380	7.535	
265	8.723	355	1445	0.632	1371	7.420	

**Legend**      CH1: I<sub>AC</sub>, CH2: V<sub>DCBUS</sub>, CH3: I<sub>U</sub>, CH4: V<sub>AC</sub>

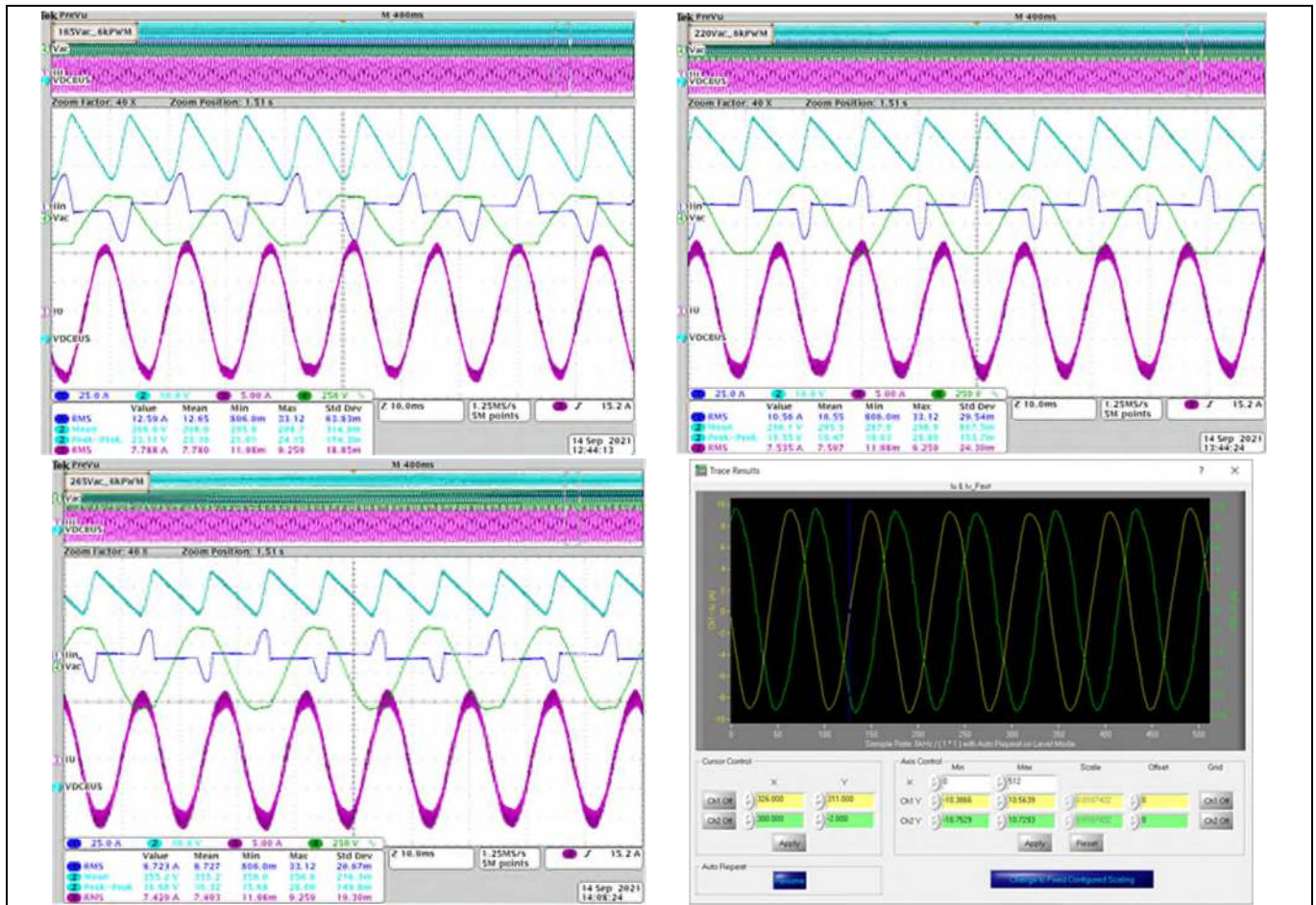

**Figure 23**      **Input voltage range and output**

**System performance**

**4.2 Bus capacitors and V<sub>DC</sub> ripple**

**Table 9 Bus capacitors and V<sub>DC</sub> ripple**

<b>Specification</b>	< 10%
<b>Condition</b>	Typical PWM setup for a 6 KHz motor PWM, 3-phase only mode, motor speed = 1400 rpm, T <sub>A</sub> = 29°C, T <sub>C</sub> = 90°C
<b>Conclusion</b>	V <sub>DC</sub> ripple is 2.3 - 5.6% (8.17 V - 11.65 V) at 1500 W run (165 V <sub>AC</sub> - 265 V <sub>AC</sub> ), motor speed = 1400 rpm

**Test Data**

<b>Input voltage (V<sub>AC</sub>)</b>	<b>PFC DC target (V)</b>	<b>Ripple voltage (V)</b>	<b>(%)</b>	<b>Test waveform</b>
165	208	23.11	5.6	Figure 24
220	296	19.55	3.3	Figure 25
265	355	16.66	2.3	Figure 26

**Legend** CH1: I<sub>AC</sub>, CH2: V<sub>DCBUS</sub>, CH3: I<sub>U</sub>, CH4: V<sub>AC</sub>

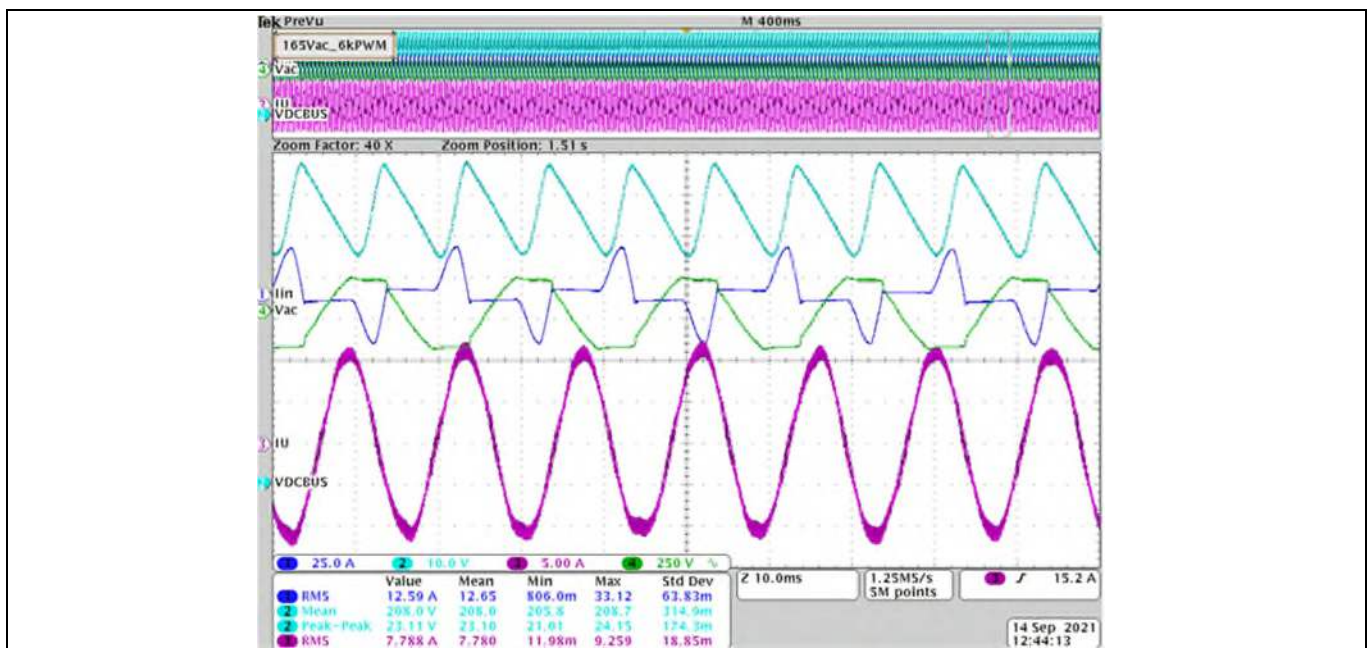

**Figure 24 Input voltage = 165 V**

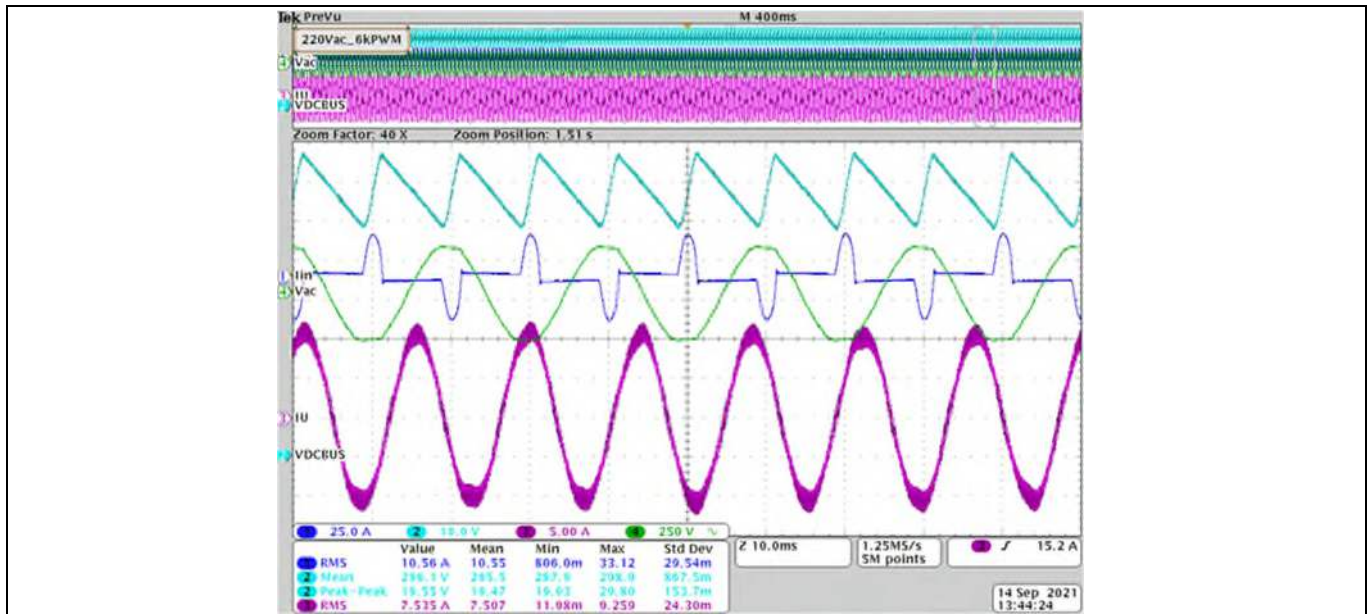

**Figure 25** Input voltage = 220 V

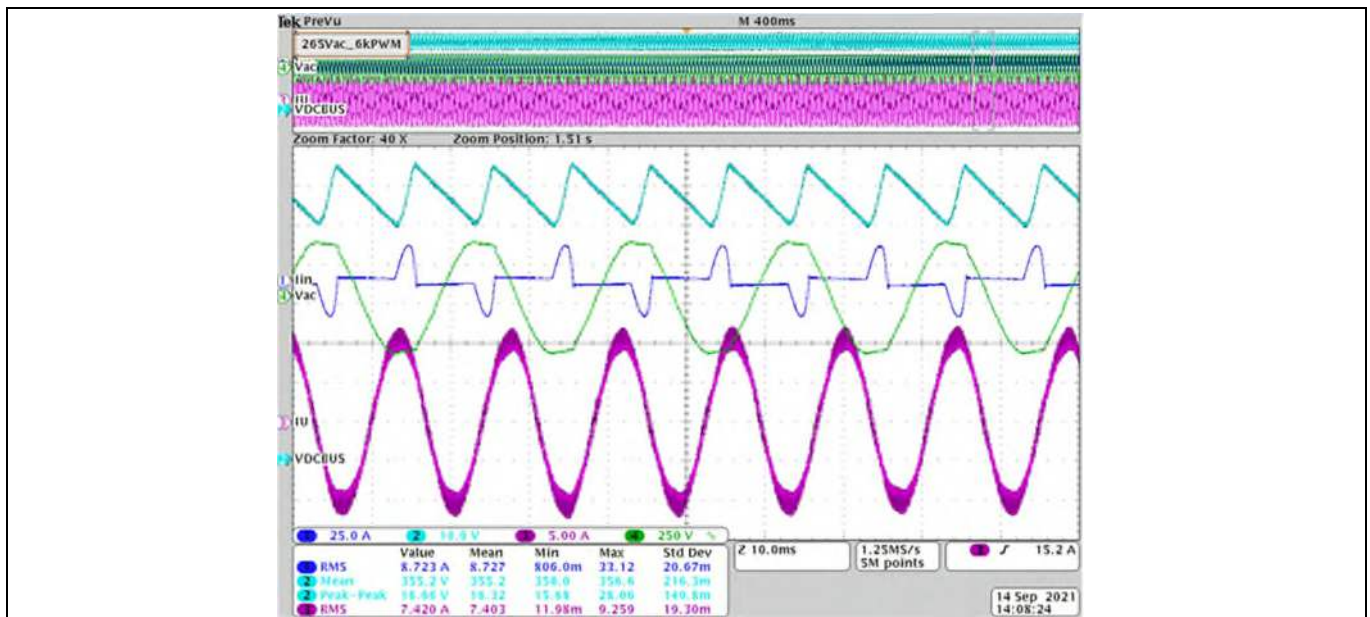

**Figure 26** Input voltage = 265 V

### 4.3 Output current and PWM frequency range test

**Table 10** Output current and PWM range

<b>Specification</b>	Output current is maximum 7 A <sub>rms</sub>
<b>Condition</b>	T <sub>A</sub> = 29°C, T <sub>C</sub> = 90°C 5 20 kHz PWM AC input voltage = 220 V/50 Hz GK0681 motor speed = 1400 rpm

**System performance**

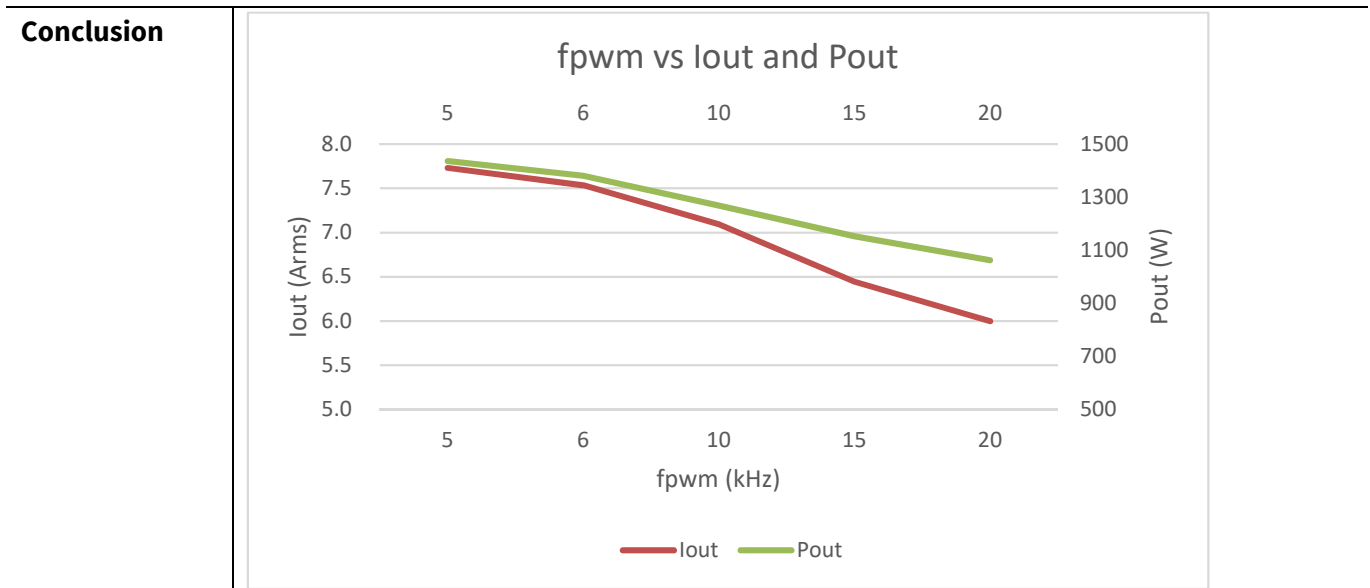

<b>Test Data</b>									
<b>PWM frequency (kHz)</b>	<b>I<sub>AC</sub> (A<sub>rms</sub>)</b>	<b>P<sub>F</sub></b>	<b>I<sub>out</sub> (A<sub>rms</sub>)</b>	<b>P<sub>out</sub> (W)</b>	<b>T<sub>C</sub> (°C)</b>	<b>ΔT<sub>C</sub> (°C)</b>	<b>V<sub>TH</sub> (V)</b>	<b>V<sub>fan+</sub> (V)</b>	<b>Test waveform</b>
5	11.09	0.617	7.731	1436	86.8	57.8	1.145	14.330	Figure 27
6	10.43	0.630	7.535	1381	87.7	58.7	1.142	14.366	
10	9.79	0.623	7.094	1269	87.7	58.7	1.141	14.368	
15	9.047	0.610	6.446	1153	87.7	58.7	1.148	14.286	
20	8.43	0.606	5.997	1062	87.9	58.9	1.142	14.364	
<b>Legend</b>									



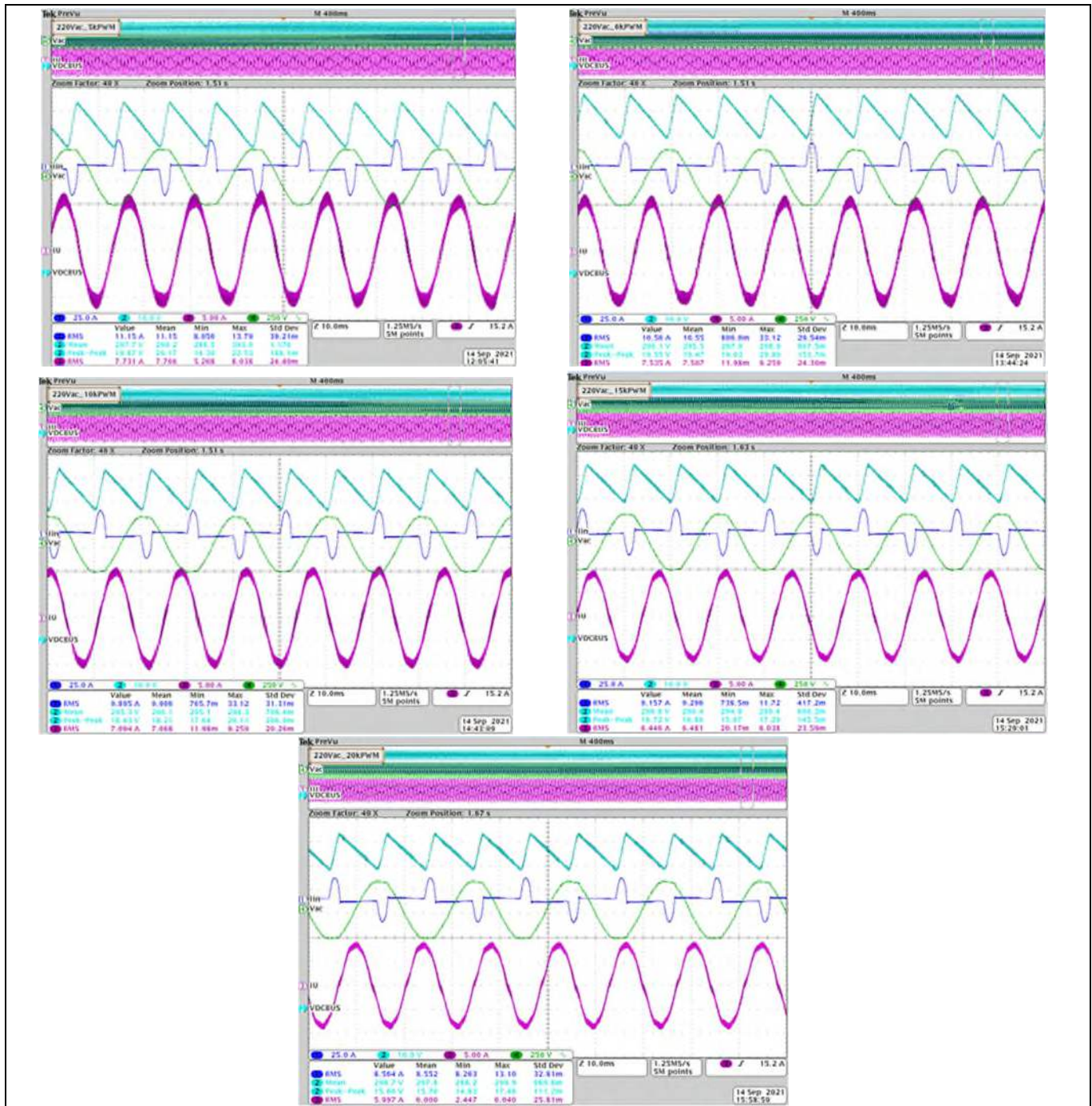
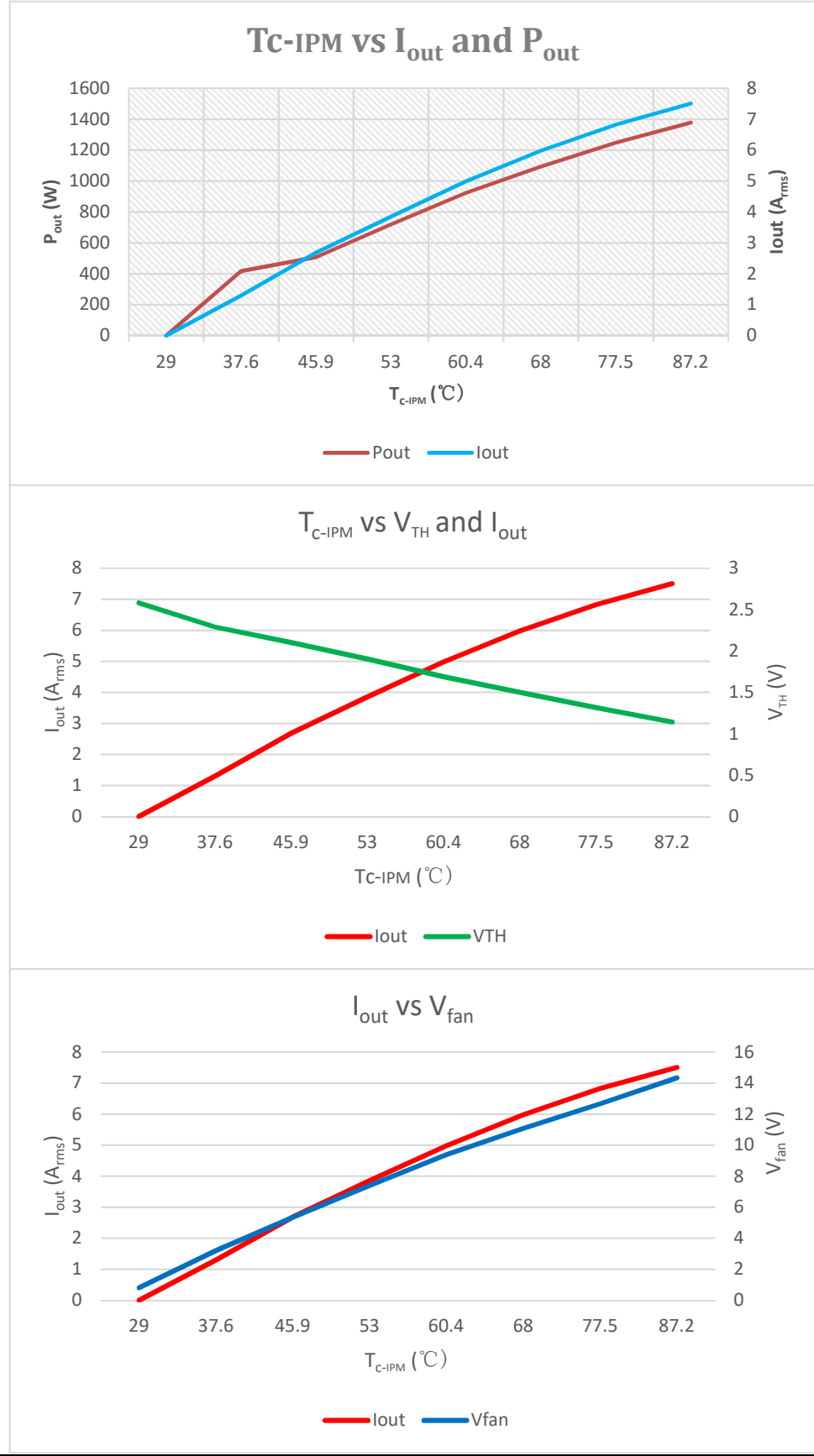

**Figure 27** Output current for different PWM frequencies

#### 4.4 Case temperature of IPM vs. output power and $V_{TH}$

<b>Specification</b>	Output power is maximum 1500 W
<b>Condition</b>	$T_A = 29^\circ\text{C}$ , 6 kHz PWM, AC-input voltage = 220 V/50 Hz, GK0681 motor speed = 1400 rpm

**Conclusion**



**System performance**

Test Data									
PWM frequency (kHz)	I <sub>AC</sub> (A <sub>rms</sub> )	PF	I <sub>out</sub> (A <sub>rms</sub> )	P <sub>out</sub> (W)	T <sub>C</sub> (°C)	ΔT <sub>C</sub> (°C)	V <sub>TH</sub> (V)	V <sub>fan+</sub> (V)	Test waveform
6	2.330	0.507	1.298	418	37.6	8.6	2.292	3.212	
	4.327	0.553	2.686	507	45.9	16.9	2.102	5.358	
	5.887	0.572	3.854	720	53.0	24.0	1.903	7.400	
	7.347	0.591	4.986	924	60.4	31.4	1.689	9.392	
	8.655	0.600	5.976	1094	68.0	39.0	1.501	11.072	
	9.782	0.609	6.824	1248	77.5	48.5	1.316	12.672	
	10.750	0.612	7.506	1378	87.2	58.2	1.143	14.345	
<b>Legend</b>									

**4.5 Heat sink thermal resistance test result**

To test the thermal impedance of a heat sink to the ambient R<sub>TH(C-A)</sub>, the DC source conducts the IPM’s internal diodes, as shown in Figure 28. As the DC source voltage increases, the current through IPM I<sub>IPM</sub> and the voltage on IPM V<sub>IPM</sub> are monitored by the current and voltage meter. The IPM case-temperature test point is between the IPM and the heat sink. It is the same as the T<sub>C</sub> point of the inverter IGBT in the IPM datasheet.

**Table 11 Table 5 Heat sink temperature vs. fan voltage**

<b>Specification</b>	T <sub>HS Max</sub> = 90°C at T <sub>A</sub> = 25°C
<b>Condition</b>	$R_{TH(J-A)} = R_{TH(J-C)} + R_{TH(J-A)}$ $R_{TH(C-A)} = \frac{\Delta T_{CA}}{P_{tot}} = \frac{T_C - T_A}{V_{IPM} \times I_{IPM}}$
<b>Conclusion</b>	

Data								
DC current (A)	DC voltage (V)	DC power (W)	T <sub>A</sub> (°C)	T <sub>C</sub> (°C)	ΔT (°C)	R <sub>th</sub> (°C/W)	Image	
4.080	2.562	31.4	28.7	89.9	61.2	1.9	Figure 28 Figure 29	
4.413	2.619	34.7	29.1	90.1	61.0	0.9		
4.773	2.675	38.3	29.0	89.0	60.9	0.8		
4.940	2.699	40.0	29.5	90.1	60.6	0.8		
5.260	2.748	43.4	30.0	90.1	60.1	0.7		
5.363	2.765	44.5	30.9	90.4	59.5	0.7		
5.510	2.782	46.0	30.9	90.1	59.2	0.6		
5.597	2.798	47.0	30.5	90.5	60.0	0.6		
5.767	2.842	49.2	30.6	90.4	59.8	0.6		
5.803	2.831	49.3	31.0	90.7	59.7	0.6		
5.887	2.853	50.4	30.4	90.6	60.2	0.6		
5.927	2.862	50.9	30.2	90.0	59.8	0.6		
<b>Legend</b>								



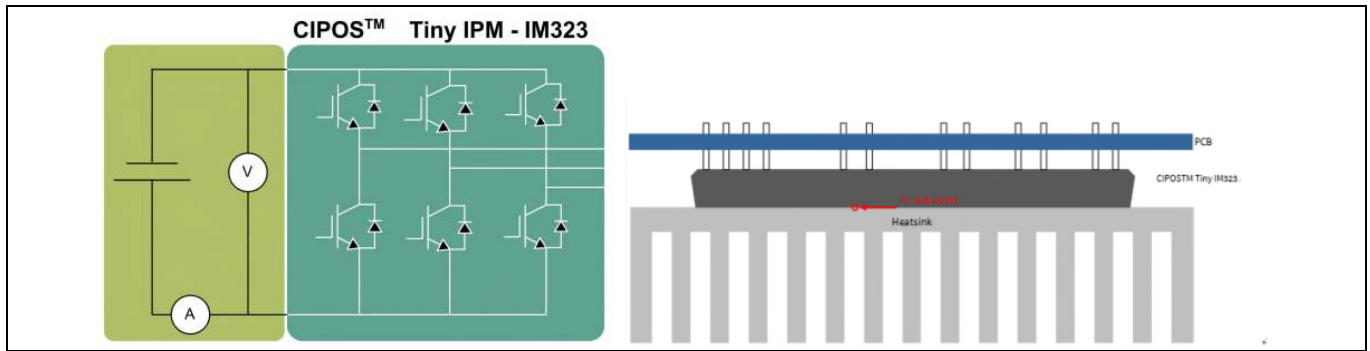

**Figure 28 Heat sink thermal testing setup**

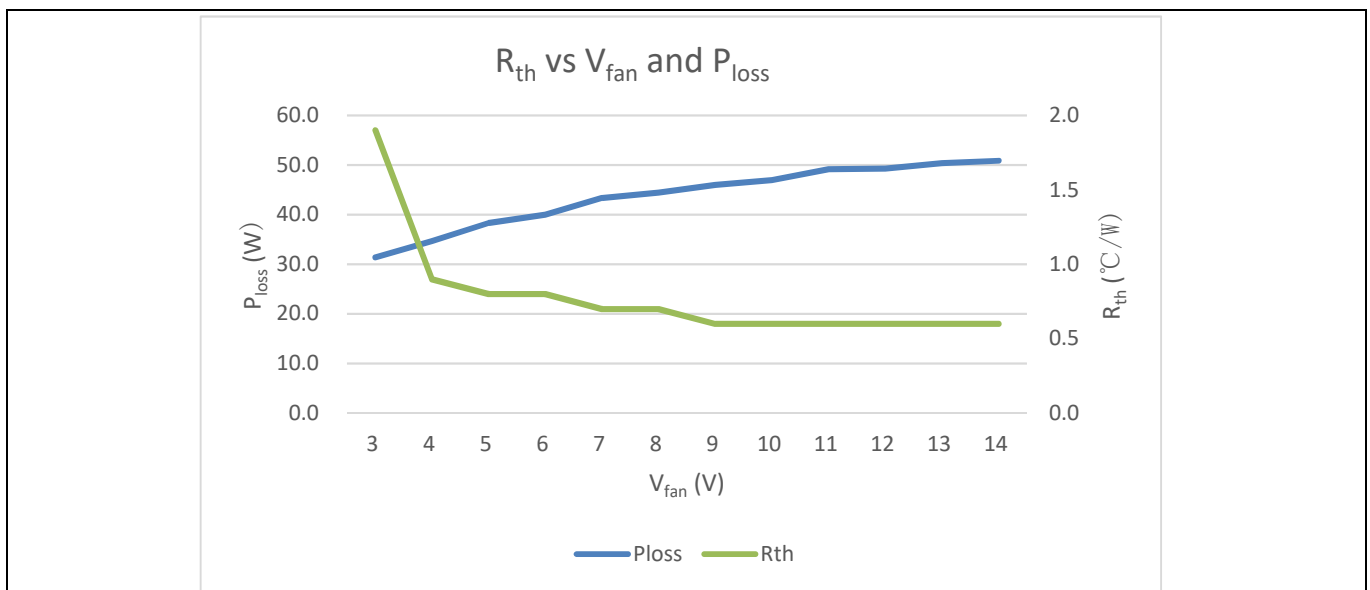

**Figure 29 Input voltage is 15 V**

## 4.6 Auxiliary power supply

**Table 12 Auxiliary power supply**

<b>Specification</b>	3.3 V ±2%, maximum 400 mA; 15 V ±5%, maximum 500 mA
<b>Condition</b>	165  265 V <sub>AC</sub>
<b>Conclusion</b>	3.3 V and 15 V accuracy is less than 1%

**System performance**

Test Data							
AC input voltage (V)	3.3 V (V)	Load (mA)	Accuracy (%)	15 V (V)	Load (mA)	Accuracy (%)	Test waveform
165	3.312	0	0.4	14.92	0	0.5	Figure 30
	3.309	100	0.3	14.92		0.5	
	3.302	200	0.1	14.92		0.5	
	3.294	300	0.2	14.92		0.5	
	3.288	400	0.4	14.92		0.5	
	3.317	0	0.5	14.90	500	0.7	
	3.309	100	0.3	14.90		0.7	
	3.300	200	0	14.91		0.6	
	3.294	300	0.2	14.91		0.6	
	3.288	400	0.4	14.91		0.6	
220	3.315	0	0.5	14.92	0	0.5	Figure 30
	3.309	100	0.3	14.92		0.5	
	3.305	200	0.2	14.92		0.5	
	3.300	300	0	14.92		0.5	
	3.286	400	0.4	14.92		0.5	
	3.317	0	0.5	14.90	500	0.7	
	3.308	100	0.2	14.90		0.7	
	3.302	200	0.1	14.90		0.7	
	3.294	300	0.2	14.91		0.6	
	3.287	400	0.4	14.90		0.7	
265	3.315	0	0.5	14.92	0	0.5	Figure 30
	3.312	100	0.4	14.92		0.5	
	3.303	200	0.1	14.92		0.5	
	3.296	300	0.1	14.92		0.5	
	3.289	400	0.3	14.92		0.5	
	3.316	0	0.5	14.91	500	0.6	
	3.311	100	0.3	14.91		0.6	
	3.302	200	0.1	14.90		0.7	
	3.295	300	0.2	14.91		0.6	
	3.286	400	0.4	14.91		0.6	
<b>Legend</b>	CH3: 3.3 V, CH4: 15 V						

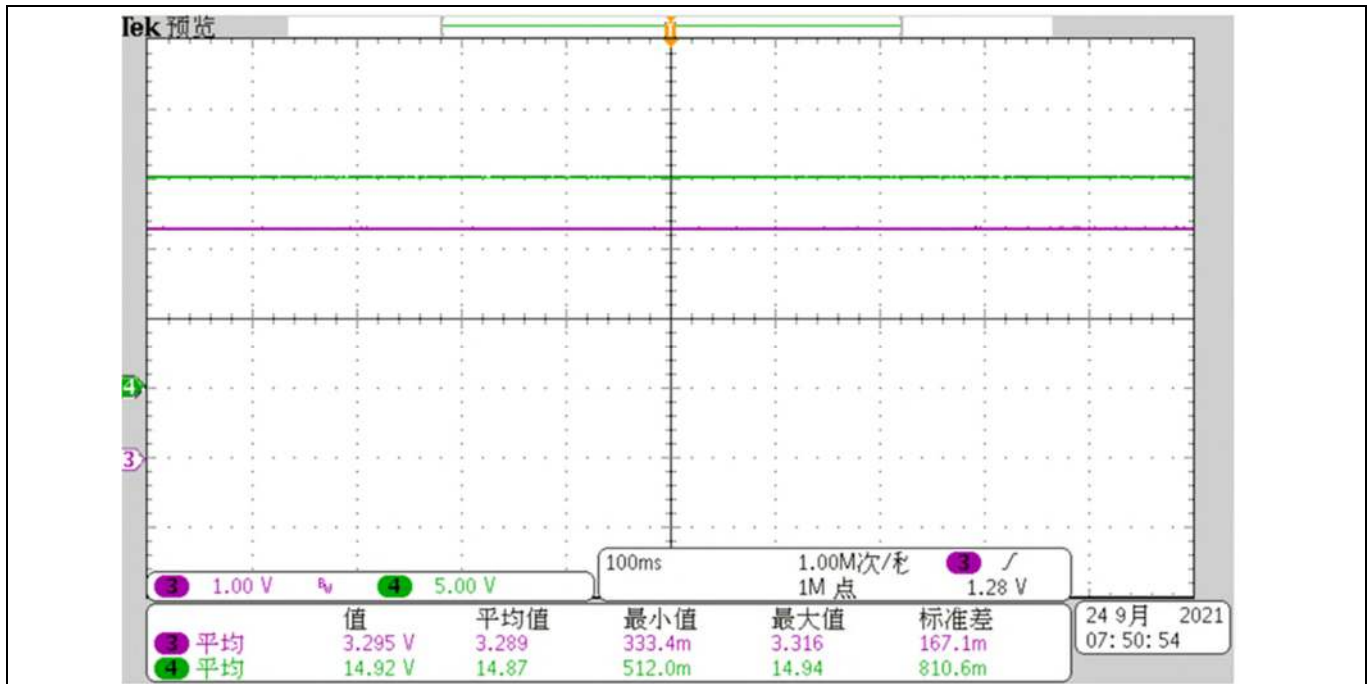

Figure 30 3.3 V and 15 V type waveform

## 4.7 Inrush current test

Table 13 Inrush current

<b>Specification</b>	Max. 30 A <sub>peak</sub>
<b>Condition</b>	<ul style="list-style-type: none"> <li>Maximum AC input voltage</li> <li>Under 30 A<sub>peak</sub></li> </ul>
<b>Conclusion</b>	Maximum current is 21.25 A <sub>peak</sub> when AC input voltage equals 265 V

### Test Data

Ac input voltage (V <sub>AC</sub> )	Phase angle (°C)	Max current (A <sub>peak</sub> )	Test waveform
220	0	11.45	Figure 31
	90	13.91	
	270	13.37	
265	0	20.996	
	90	21.25	
	270	20.99	

**Legend** CH1: I<sub>AC</sub>, CH2: V<sub>AC</sub>, CH3: V<sub>DCBUS</sub>

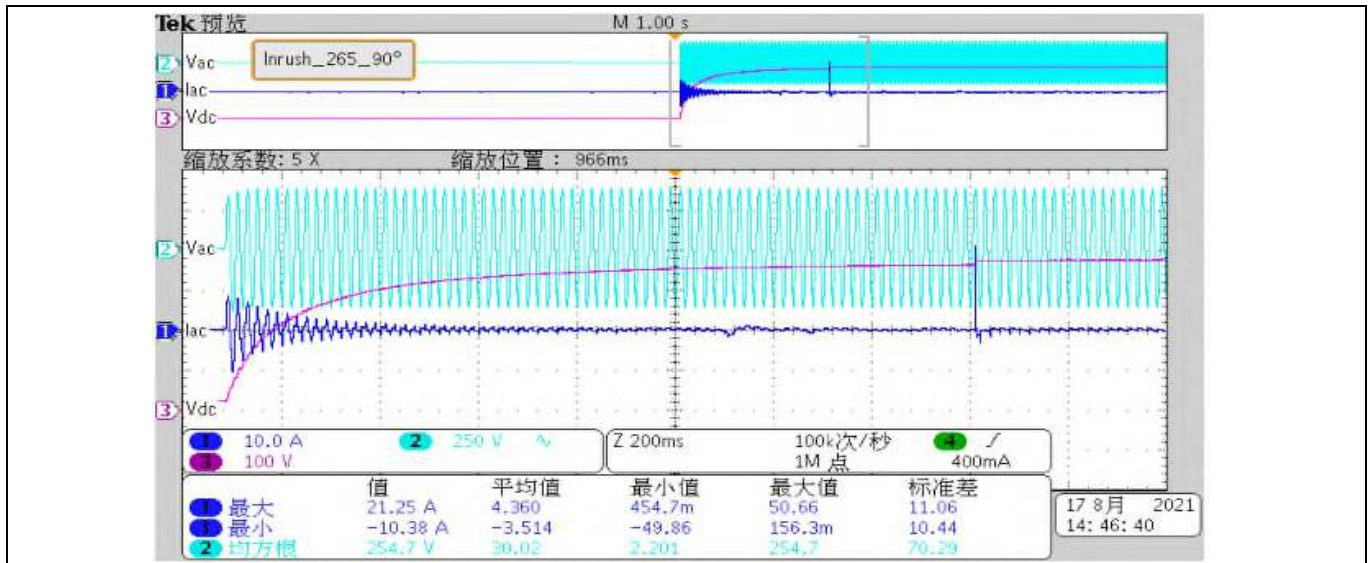

Figure 31 Power-off 220 V<sub>AC</sub>

## 4.8 Overcurrent protection (OCP)

Table 14 Motor OCP (IMC101T internal comparator)

<b>Specification</b>	OCP point is 20 A <sub>peak</sub>
<b>Condition</b>	<ul style="list-style-type: none"> <li>Run the motor normally and increase the torque continuously until OCP is triggered</li> <li>The OCP threshold is set to 21.5 A<sub>peak</sub></li> </ul>
<b>Conclusion</b>	Meets OCP requirement of 20 A <sub>peak</sub>

### Test Data

Operating cycle	OCP current peak value	Test waveform
1	20.54	Figure 32
2	21.33	Figure 33
<b>Legend</b>	CH1: I <sub>v</sub> , CH2: I <sub>u</sub> , CH3: GK, CH4: V <sub>DCBUS</sub>	



**Figure 32** First cycle



**Figure 33** Second cycle

**System performance**

**4.9 Short-protection**

**Table 15 Motor output short-protection**

<b>Specification</b>	Meet IPM's 3 μs short-circuit withstand time, fault-clear time is set to minimum 100 μs
<b>Condition</b>	Run the motor and quickly short-circuit U and V phase
<b>Conclusion</b>	ITRIP response time is 1.2 μs and fault-clear time is more than 100 μs

**Test data**

Operation	Phenomenon (μs)	Test waveform
Short U and V phase		Figure 34
T <sub>FLT</sub>	1.2	Figure 35
T <sub>ITRIP</sub>	1.68	Figure 36
T <sub>FLT-CLR</sub>	>100	Figure 37
<b>Legend</b>	CH1: I <sub>U</sub> , CH2: V <sub>U_phase</sub> , CH3: GK, CH4: ITRIP	

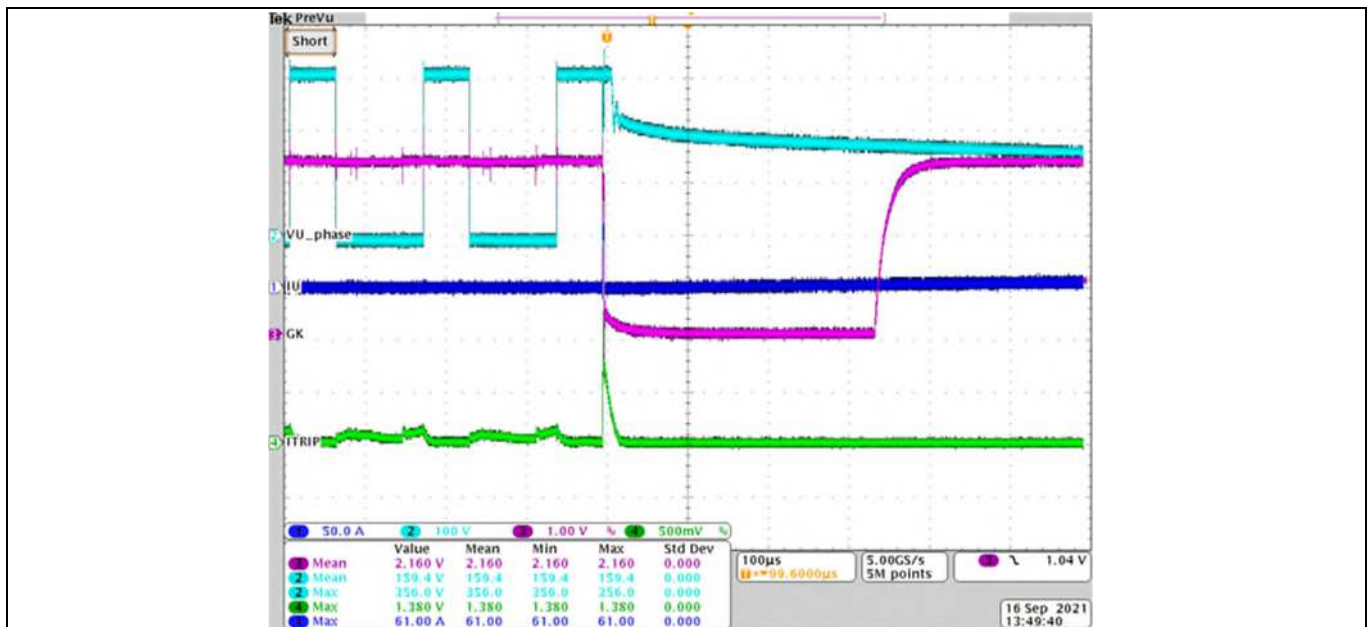

**Figure 34 Short-protection**



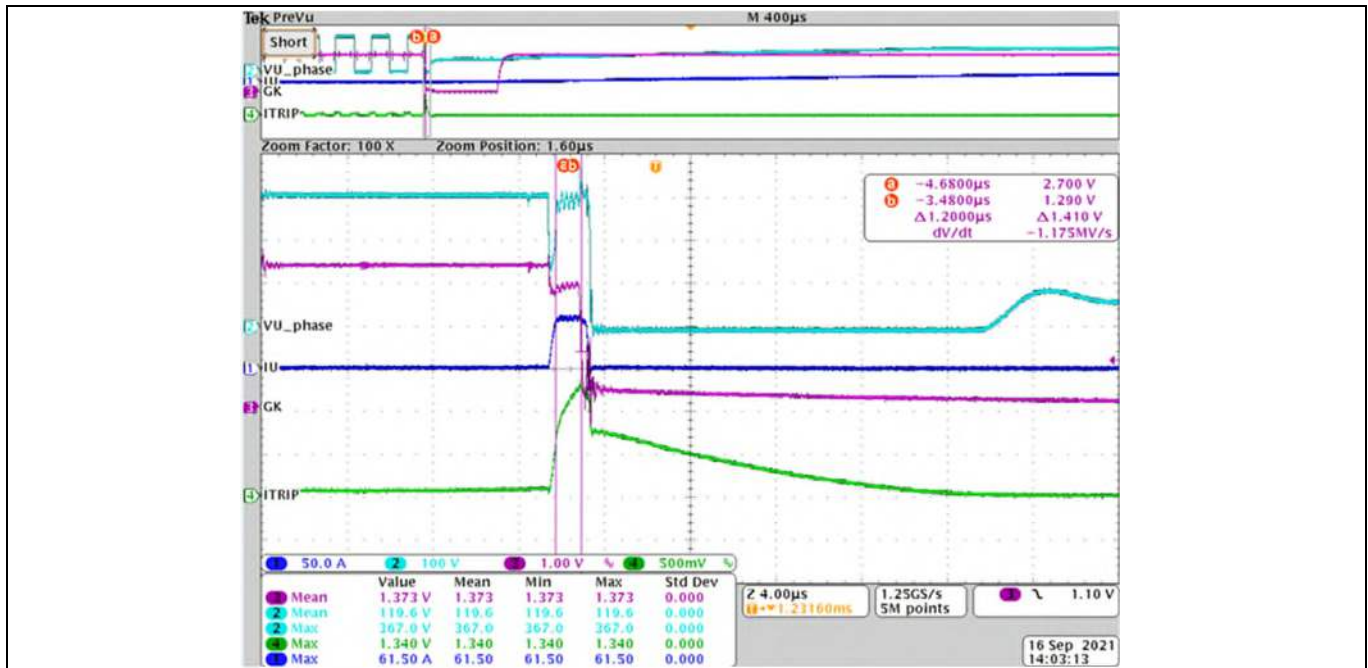

Figure 35  $T_{FLT}$  time

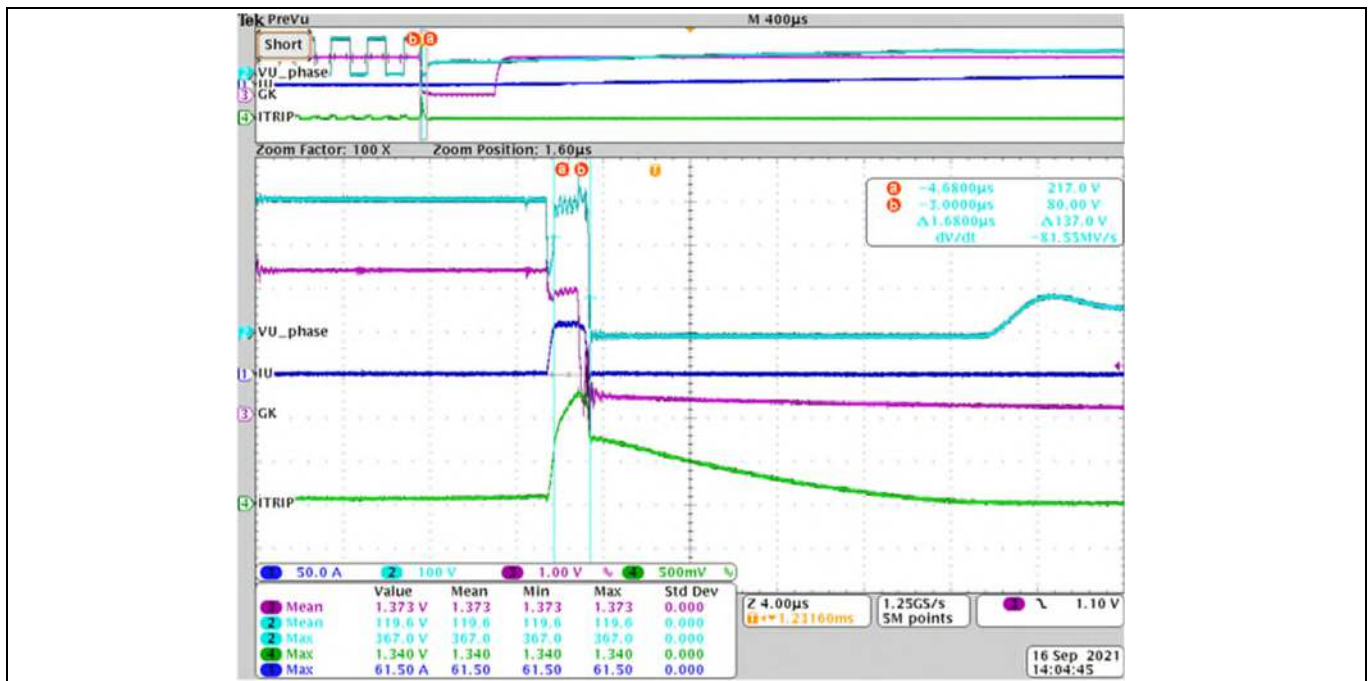

Figure 36  $T_{ITRIP}$  time





**Figure 37**  $T_{FLT-CLR}$  time

## 4.10 Overvoltage protection (OVP)

**Table 16** Overvoltage protection

<b>Specification</b>	Report fault at the setup OVP point
<b>Condition</b>	Run motor and increase input voltage
<b>Conclusion</b>	Overvoltage triggered as expected

### Test data

Operation	Phenomenon	Test waveform
Set the value of Question 47 – DC bus over-voltage level in the Wizard as 360 V and run only the motor, normally. Increase the $V_{AC}$ voltage slowly	OV fault occurred when the bus voltage was just over 360 V, and the motor stopped	Figure 38
<b>Legend</b>	CH1: PWMUL, CH2: $V_{DCB}$ , CH3: $V_{DCBSENSE}$ , CH4: $V_{AC}$	

System performance

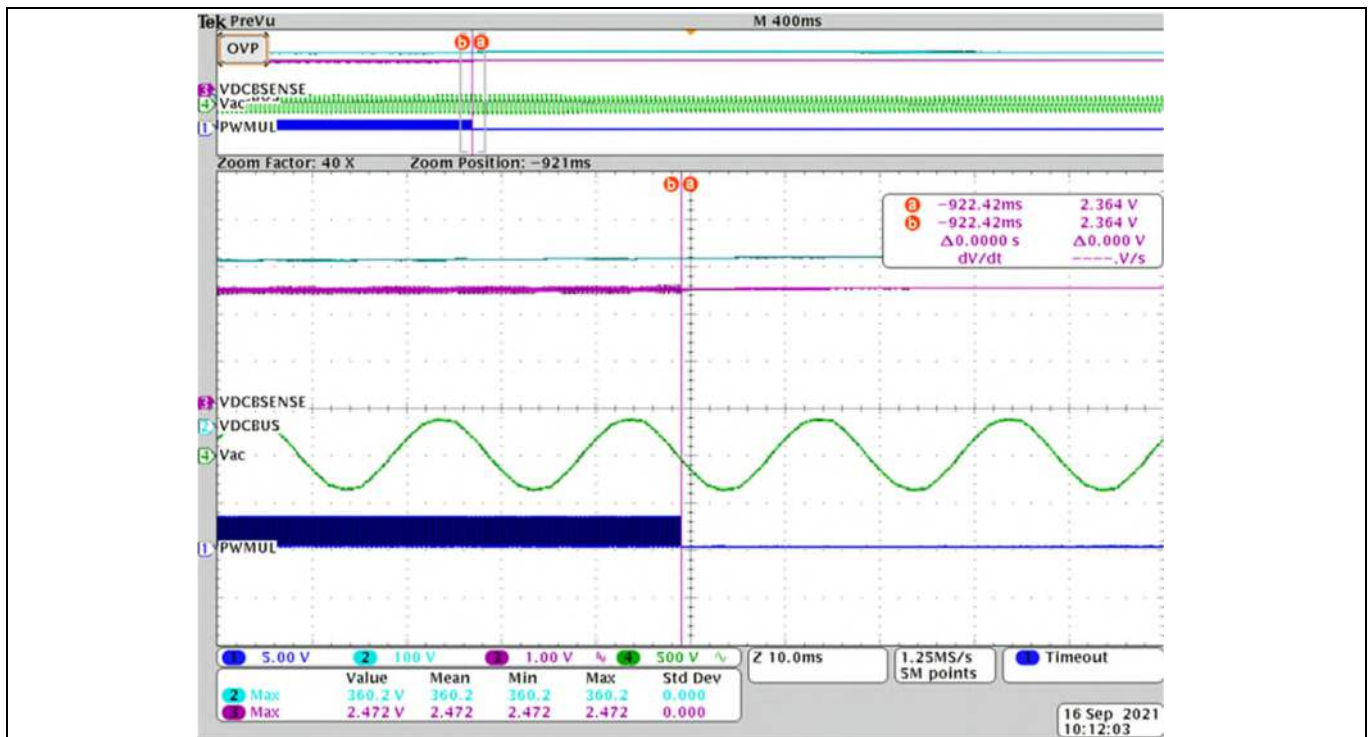

Figure 38 Overvoltage protection

### 4.11 EMC test

Table 17 EMI

<b>Specification</b>	Compliant with IEC standards IEC-61000-4-5
<b>Condition</b>	Type 6 kHz PWM
<b>Conclusion</b>	More than 3 dB margin

Test data

Trace	Frequency (MHz)	Intensity (dBμV)	Limit (dBμV)	Margin (dB)	Note	Image
2 AV	0.526	41.08	46.00	-4.92	Line	Figure 39
2 AV	10.034	44.92	50.00	-5.08		
1 PK+	10.238	56.31	60.00	-3.69		
1 PK+	10.854	54.55	60.00	-5.45		
2 AV	0.814	41.39	46.00	-4.61	Neutral	Figure 40
1 PK+	9.742	54.81	60.00	-5.19		
1 PK+	9.822	54.81	60.00	-5.19		
<b>Legend</b>						

**System performance**

*Note: The EMI test is directly affected by the test environment and method. The results of the EMI test in this document are for reference only and not intended as the final design basis.*

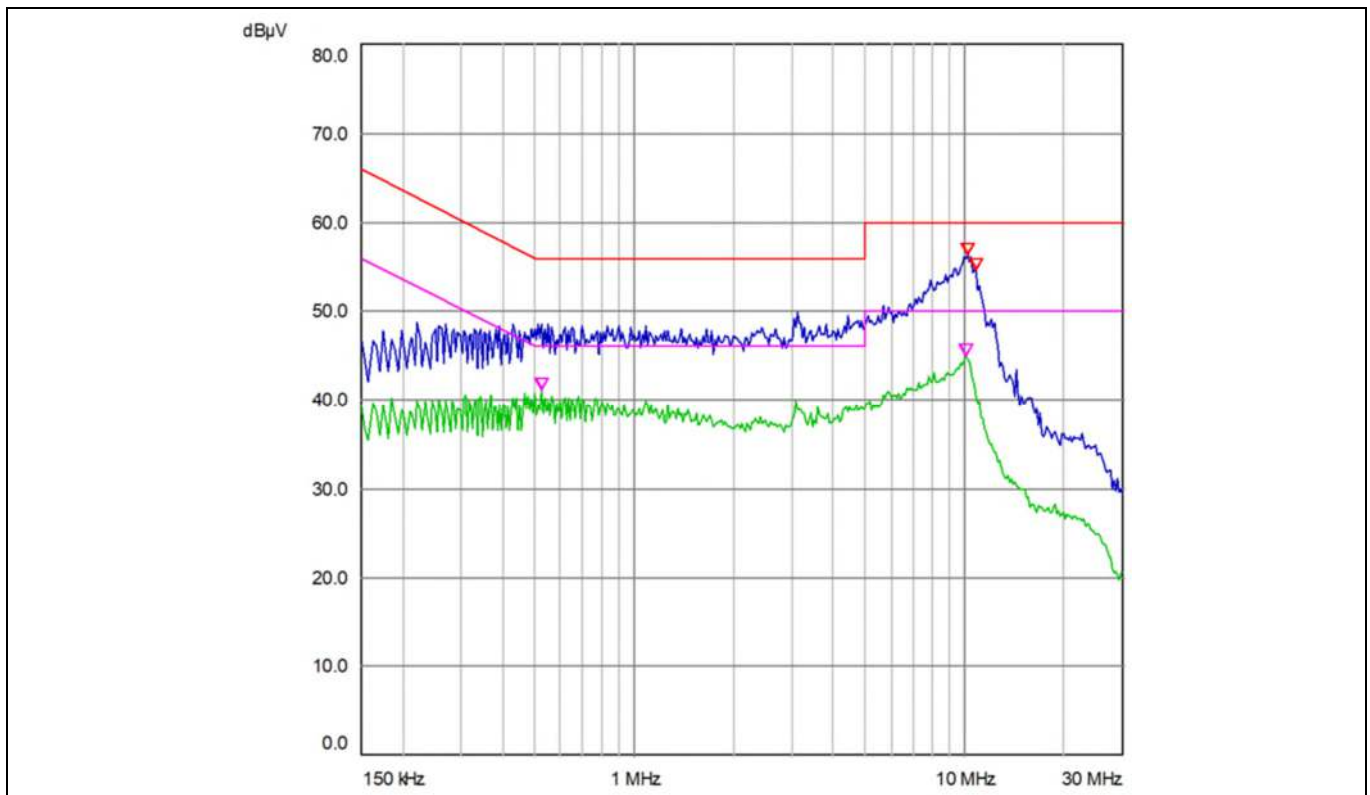

**Figure 39 Line noise**

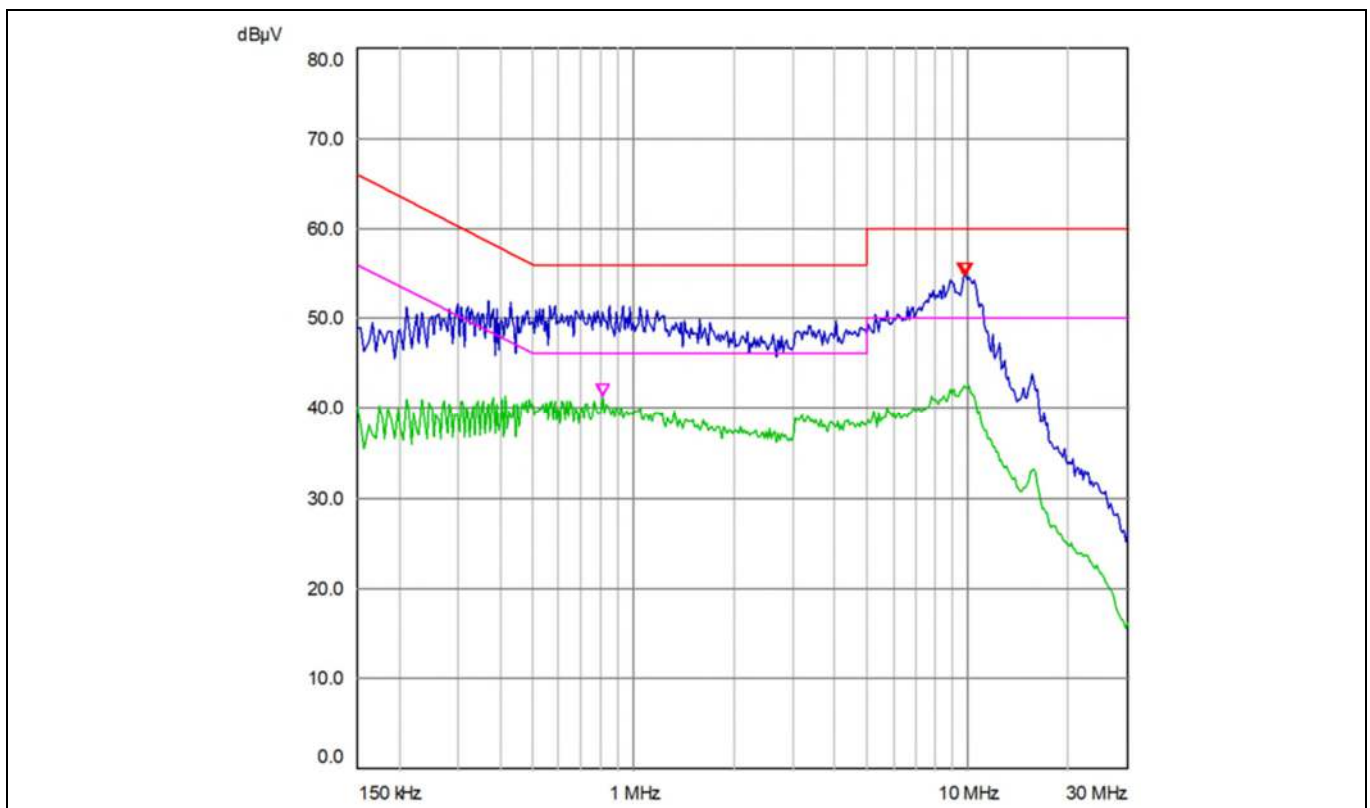

**Figure 40 Neutral noise**

**System performance**

**4.12 Surge test**

**Table 18 Surge**

<b>Specification</b>	IEC 61000-4-5 Class B
<b>Condition</b>	<ul style="list-style-type: none"> <li>EVAL-M1-101T control board</li> <li>GK6063</li> <li>IM323-L6G</li> <li>Lightning surge simulator LSS-6230</li> <li>L-N 2kV, L/N-PE 4 kV</li> </ul>
<b>Conclusion</b>	All pass

**Test data**

Pulse voltage (V)	Basic voltage (V <sub>rms</sub> )	Connection	Waveform	Coupling impedance	ASync/Sync Angle	Times	Pass condition	Result
2000	220	L-N	1.2/50 μs	18 μF	ASync	5	<ul style="list-style-type: none"> <li>No Fault</li> <li>No damage to components</li> </ul>	pass
2000	220	L-N	1.2/50 μs	18 μF	Sync 0°	5		pass
2000	220	L-N	1.2/50 μs	18 μF	Sync 90°	5		pass
2000	220	L-N	1.2/50 μs	18 μF	Sync 180°	5		pass
2000	220	L-N	1.2/50 μs	18 μF	Sync 270°	5		pass
2000	220	L-N	1.2/50 μs	18 μF	ASync	5		pass
2000	220	L-N	1.2/50 μs	18 μF	Sync 0°	5		pass
2000	220	L-N	1.2/50 μs	18 μF	Sync 90°	5		pass
2000	220	L-N	1.2/50 μs	18 μF	Sync 180°	5		pass
2000	220	L-N	1.2/50 μs	18 μF	Sync 270°	5		pass
4000	220	L-PE/N-PE	1.2/50 μs	9 μF + 10 Ω	ASync	5		pass
4000	220	L-PE/N-PE	1.2/50 μs	9 μF + 10 Ω	Sync 0°	5		pass
4000	220	L-PE/N-PE	1.2/50 μs	9 μF + 10 Ω	Sync 90°	5		pass
4000	220	L-PE/N-PE	1.2/50 μs	9 μF + 10 Ω	Sync 180°	5		pass
4000	220	L-PE/N-PE	1.2/50 μs	9 μF + 10 Ω	Sync 270°	5		pass

**Legend**

**4.13 Electrical fast transient (EFT) test**

**Table 19 EFT test**

<b>Specification</b>	IEC 61000-4-4 Class B
<b>Condition</b>	For input connector only
<b>Conclusion</b>	Pass

**System performance**

<b>Test data</b>				
<b>Item</b>	<b>V<sub>peak</sub></b>	<b>Frequency</b>	<b>Time</b>	<b>Result</b>
L-N	±2 kV	5/100 kHz	15/300 ms	Pass
L-PE	±2 kV	5/100 kHz	15/300 ms	Pass
N-PE	±2 kV	5/100 kHz	15/300 ms	Pass
<b>Legend</b>				

## Acronyms

**Table 20 Abbreviations**

<b>Abbreviation</b>	<b>Meaning</b>
AC	Alternating current
AD	Altium designer
CAP	Capacitance
CCM	Continuous conduction mode
CE	Conformité Européenne
CERA	Ceramic
EMI	Electromagnetic interference
EMC	Electromagnetic compatibility
ESD	Electrostatic discharge
EFT	Electrical fast transient
DC	Direct current
DCBUS	Direct current bus voltage
DCM	Discontinuous conduction mode
DCP	Direct current bus voltage positive
ELCO	Electrolytic capacitor
FILM	Film capacitor
GUI	Graphical user interface
GDT	Gas discharge tube
IC	Integrated circuit
IGBT	Insulated gate bipolar translator
IPM	Intelligent power module
LED	Light emitting diode
MADK	Modular application design kit
MCE	Motion control engine
NTC	Negative temperature coefficient
OCP	Overcurrent protection
PC	Personal computer
PCB	Printed circuit board
PCN	Process change notification
PD	Product discontinuation
PE	Protect earth
PGND	Protect ground
PLL	Phase locking loop
PTC	Positive temperature coefficient
PWM	Pulse-width modulation
RES, R	Resistor
RMA	Returned material analysis

**System performance**

<b>Abbreviation</b>	<b>Meaning</b>
RoHS	Restriction of hazardous substances in electrical and electronic equipment
SGND	Secondary ground
SOI	Silicon-on-insulator
UART	Universal asynchronous receiver/transmitter
USB	Universal serial bus
UVW	U phase/V phase/W phase
VCC	Voltage circuit



## **References**

- [1] Infineon Technologies AG. Datasheet of Infineon IM323 (202x). V1.0 [www.infineon.com](http://www.infineon.com)
- [2] Infineon Technologies AG. Datasheet of Infineon IMC101T-T038 (2019). V1.4 [www.infineon.com](http://www.infineon.com)
- [3] Infineon Technologies AG. MCEWizard\_V2.3.0.0 User Guide (2019) [www.infineon.com](http://www.infineon.com)
- [4] Infineon Technologies AG. MCEDesigner\_V2.3.0.0 Application Guide (2019) [www.infineon.com](http://www.infineon.com)
- [5] Infineon Technologies AG. iMOTION™ Motion Control Engine Software Reference Manual (2020) V1.3 [www.infineon.com](http://www.infineon.com)

**Revision history**

**Revision history**

<b>Document version</b>	<b>Date</b>	<b>Description of changes</b>
V1.0	18-05-2022	User guide initial release

**Trademarks**

All referenced product or service names and trademarks are the property of their respective owners.

**Edition 2022-03-15****Published by****Infineon Technologies AG****81726 Munich, Germany****© 2022 Infineon Technologies AG.****All Rights Reserved.****Do you have a question about this document?****Email: [erratum@infineon.com](mailto:erratum@infineon.com)****Document reference****UG-2021-38****WARNINGS**

Due to technical requirements products may contain dangerous substances. For information on the types in question please contact your nearest Infineon Technologies office.

Except as otherwise explicitly approved by Infineon Technologies in a written document signed by authorized representatives of Infineon Technologies, Infineon Technologies' products may not be used in any applications where a failure of the product or any consequences of the use thereof can reasonably be expected to result in personal injury.