

Real Time Clock Module with SPI Bus

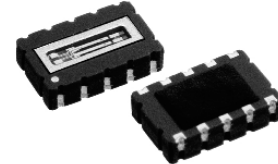

5.0 x 3.2 x 1.2 mm

AB-RTCMC-32.768kHz-ZIZE-S2



RoHS/RoHS II compliant

Moisture Sensitivity Level: MSL=1

FEATURES:

- RTC module with built-in “Tuning Fork” crystal oscillating at 32.768 kHz
- Ultra low power consumption: 130nA typ @ VDD = 3.0V / Tamb = 25°C
- Wide clock operating voltage: 1.1 – 5.5V
- Wide Interface operating voltage: 1.6 – 5.5V
- User programmable Frequency Offset Compensation Register for improved time accuracy
- 4-wire SPI-Interface with a maximum data rate of 6.25 Mbits/s.
- Provides year, month, day, weekday, hours, minutes, seconds
- Alarm and Timer functions, internal low-voltage detector, power-on reset and watchdog function.
- Open-drain Interrupt and programmable CLKOUT pins for peripheral devices (32.768kHz down to 1Hz)
- Small and compact package-size of 5.0 x 3.2 x 1.2mm, RoHS-compliant and 100% lead-free.

APPLICATIONS:

- Wide range in communication & measuring equipment
- Commercial & Industrial applications
- Automotive electronics applications
- Wireless communications
- PDA and Palm Pilots
- Credit Cards with Security Technology

STANDARD SPECIFICATIONS:

Absolute Maximum Ratings

Parameters	Min.	Typ.	Max.	Units	Notes
Power Supply Voltage (V _{DD})	GND-0.5		+6.5	V	>GND / <V _{DD}
Supply Current (I _{DD} ; I _{SS})	-50		+50	mA	V _{DD} Pin
Input Voltage (V _I)	GND-0.5		V _{DD} +0.5	V	Input Pin
Output Voltage (V _O)	GND-0.5		V _{DD} +0.5	V	$\overline{\text{INT}}$ / CLKOUT
DC Input Current (I _I)	-10		+10	mA	
DC Output Current (I _O)	-10		+10	mA	
Total Power Dissipation (P _{TOT})			300	mW	
Operating Temperature Range (T _{OPR})	-40		+85	°C	
Storage Temperature (T _{STO})	-55		+125	°C	Stored as bare product

Frequency and Time Characteristics

V_{DD}=3.0V; V_{SS}=0V; T_{AMB}=+25°C; f_{OSC}=32.768kHz

Parameters	Min.	Typ.	Max.	Units	Notes
Frequency Accuracy (ΔF/F)		±10	±20	ppm	T _{AMB} =+25°C; V _{DD} =3.0V
Frequency vs Voltage (ΔF/V)		±0.8	±1.0	ppm/V	T _{AMB} =+25°C; V _{DD} =1.8~5.5V
Frequency vs Temperature (ΔF/T _{OPR})	-0.035ppm/°C ² * (T _{OPR} -T _O) ² * ±10%			ppm	T _{reference} =+25°C; V _{DD} =3.0V
Turnover Temperature (T _O)	+20	+25	+30	°C	
Aging (first year)	-3		+3	ppm	T _{AMB} =+25°C
Start-up Time (T _{START})		500	1000	ms	V _{DD} =3.0V
CLKOUT duty cycle	40	50	60	%	T _{AMB} =+25°C
Achievable Time Accuracy with Correct Frequency-Offset Compensation (ΔT/T)		±3 ¹⁾	±5 ²⁾	ppm	

1) Based on customer set correct Frequency Offset Compensation in “normal” mode

2) Based on customer set correct Frequency Offset Compensation in “coarse” mode

Real Time Clock Module with SPI Bus

AB-RTCMC-32.768kHz-ZIZE-S2



RoHS/RoHS II compliant

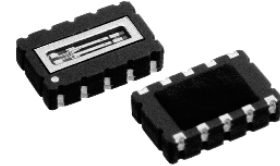

5.0 x 3.2 x 1.2 mm

Static Characteristics

$V_{DD}=1.1\sim 5.5V$; $V_{SS}=0V$; $T_{AMB}=-40^{\circ}C \sim +85^{\circ}C$; $f_{OSC}=32.768kHz$

Parameters		Min.	Typ.	Max.	Units	Notes
Supplies						
Supply Voltage (V_{DD})		1.1		5.5	V	Time-keeping mode SPI bus inactive ¹⁾
		1.6		5.5		SPI bus active
Minimum Supply Voltage Detection ($V_{OSC(min)}$)			0.9		V	$T_{AMB}=+25^{\circ}C$
Supply Current (I_{DD})	$V_{DD}=2.0V$ ²⁾		120		nA	SPI bus inactive CLKOUT disabled $T_{AMB}=+25^{\circ}C$
	$V_{DD}=3.0V$ ²⁾		130			
	$V_{DD}=5.0V$ ²⁾		140			
	$V_{DD}=2.0V$ ²⁾			350	nA	SPI bus inactive CLKOUT disabled $T_{AMB}=-40^{\circ}C \sim +85^{\circ}C$
	$V_{DD}=3.0V$ ²⁾			370		
	$V_{DD}=5.0V$ ²⁾			400		
	$V_{DD}=2.0V$		280		nA	SPI bus inactive CLKOUT enabled CLKOUT =32.768kHz $T_{AMB}=+25^{\circ}C$
	$V_{DD}=3.0V$		360			
	$V_{DD}=5.0V$		540			
	$V_{DD}=2.0V$			470	nA	SPI bus inactive CLKOUT enabled CLKOUT =32.768kHz $T_{AMB}=-40^{\circ}C \sim +85^{\circ}C$
	$V_{DD}=3.0V$			570		
	$V_{DD}=5.0V$			770		
	$f_{SCL}=4.5MHz$; $V_{DD}=5.0V$		250	400	μA	SPI bus active CLKOUT enabled $T_{AMB}=+25^{\circ}C$
	$f_{SCL}=1.0MHz$; $V_{DD}=3.0V$		30	80		
Current Consumption (I_{DD32K})	$f_{SCL}=0Hz$; $V_{DD}=5.0V$		2.5	3.4	μA	CLKOUT =32.768kHz $C_{LOAD}=7.5pF$
	$f_{SCL}=0Hz$; $V_{DD}=3.0V$		1.5	2.2		
	$f_{SCL}=0Hz$; $V_{DD}=2.0V$		1.1	1.6		
Input						
LOW Level Input Voltage (V_{IL})				$30\% * V_{DD}$	V	
HIGH Level Input Voltage (V_{IH})		$70\% * V_{DD}$			V	
Input Voltage (V_I) Pins: CL, SCL, SDI, CLKOE		-0.5		0.5	V	
Input Leakage Current (I_L)	$V_I = V_{DD}$ or V_{SS} SCL,SDI,CLKOE,CLKOUT	-1	0	+1	μA	
	$V_I = V_{SS}$ on pin CE	-1	0			
Pull-down resistance (R_{PD}) on pin CE			240	550	k Ω	

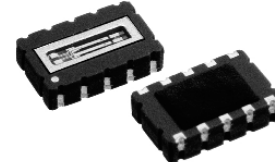

Input Capacitance (C_I) ³⁾			7	pF	
---	--	--	---	----	--

(Continued)

Parameters		Min.	Typ.	Max.	Units	Notes
Output						
Output Voltage (V_O)	Pins: CLKOUT; INT ⁴⁾	-0.5		5.5	V	
	Pin: SDO	-0.5		$V_{DD} + 0.5$		
HIGH Level Output Voltage (V_{OH}) Pin: SDO		$80\% * V_{DD}$		V_{DD}	V	
LOW Level Output Voltage (V_{OL})	Pins: CLKOUT; INT $V_{DD} = 5V / I_{OL} = 1.5mA$	V_{SS}		0.4	V	
	Pin: SDO	V_{SS}		$20\% * V_{DD}$		
HIGH Level Output Current (I_{OH}) Pin: SDO; $V_{OH} = 4.6V / V_{DD} = 5V$				1.5	mA	
LOW Level Output Current (I_{OL}) Pin: SDO, INT, CLKOUT; $V_{OL} = 0.4V / V_{DD} = 5V$		-1.5			mA	
Output Leakage Current (I_{LO}) $V_O = V_{DD}$ or V_{SS}		-1	0	+1	μA	

- 1) For reliable oscillator start-up at power-up: $V_{DD} = V_{DD(min)} + 0.3V$.
- 2) Timer source clock = 1/60 Hz, level of pins CE, SDI and SCL either V_{DD} or V_{SS} .
- 3) Implicit by design.
- 4) Refers to external pull-up voltage

Dynamic Characteristics SPI-Bus

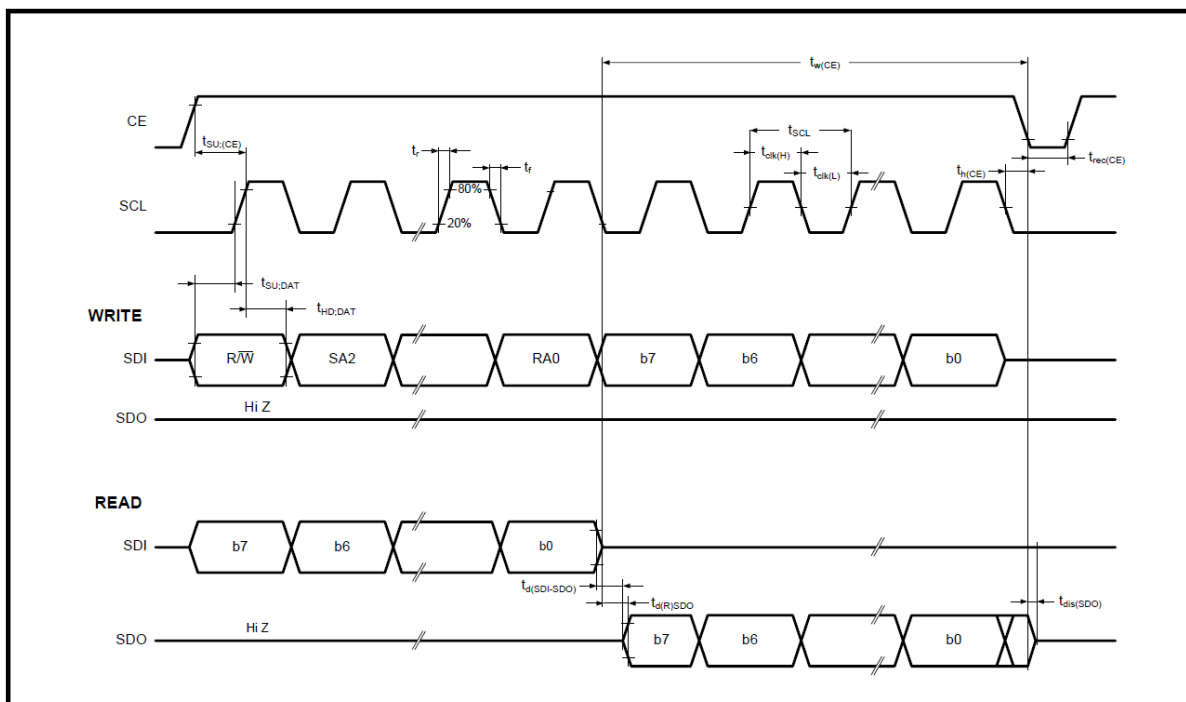

Real Time Clock Module with SPI Bus

AB-RTCMC-32.768kHz-ZIZE-S2



RoHS/RoHS II compliant

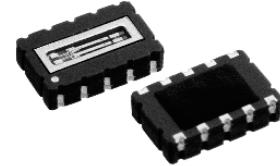

5.0 x 3.2 x 1.2 mm

Dynamic Characteristics SPI-Bus

$V_{SS}=0V$; $T_{AMB}=-40^{\circ}C \sim +85^{\circ}C$; All timing values are valid within the operating supply voltage range and references to V_{IL} and V_{IH} with an input voltage swing from V_{SS} and V_{DD} .

Parameters	$V_{DD}=1.6V$		$V_{DD}=2.4V$		$V_{DD}=3.3V$		$V_{DD}=5.0V$		Units	Notes
	Min.	Max.	Min.	Max.	Min.	Max.	Min.	Max.		
SCL Clock Frequency ($f_{clk(SCL)}$)		2.9		4.54		5.71		8.0	MHz	
SCL Time (t_{SCL})	345		220		175		125		ns	
Clock HIGH Time ($t_{clk(H)}$)	90		50		45		40		ns	
Clock LOW Time ($t_{clk(L)}$)	200		120		95		70		ns	
Rise Time		100		100		50		50	ns	For SCL signal
Fall Time		100		100		50		50	ns	For SCL signal
CE Setup Time	40		35		30		25		ns	
CE Hold Time	40		30		25		15		ns	
CE Recovery Time	30		25		20		15		ns	
CE Pulse Width		0.99		0.99		0.99		0.99	s	Measured after valid subaddress is received
Setup Time	10		5		3		2		ns	Setup time ofr SDI data
Hold Time	25		10		8		5		ns	Hold time for SDI data
SDO Read Delay Time		190		108		85		60	ns	Bus load = 50pF
SDO Disable Time		70		45		40		27	ns	No load value; bus will be held up by bus-capacitance; use RC time constant with application values
Transition Time SDI to SDO	0		0		0		0		ns	To avoid bus conflict

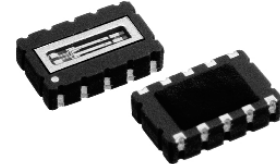

5.0 x 3.2 x 1.2 mm

AB-RTCMC-32.768kHz-ZIZE-S2



RoHS/RoHS II compliant

➤ PART IDENTIFICATIONS:

AB-RTCMC-32.768 kHz-ZIZE-S2-□

Packaging

Blank: Bulk

T: 1000pcs/reel

➤ OUTLINE DIMENSIONS:

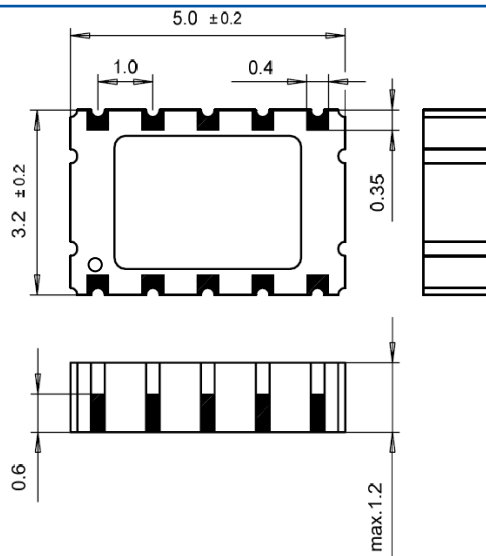

Recommended Land Pattern

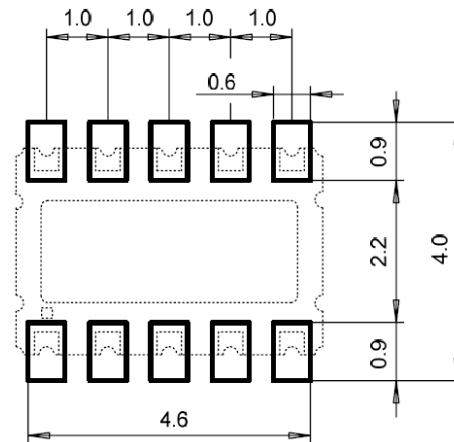

Dimensions: mm

➤ PIN DESCRIPTIONS:

Pin No.	Pin Name	Function
1	V _{DD}	Positive supply voltage; positive or negative steps in supply voltage may affect oscillator performance, recommend 10 nF decoupling capacitor close to device
2	CLKOUT	Clock Output pin; open-drain
3	SCL	Serial Clock Input pin; may float when CE inactive
4	SDI	Serial Data Input pin; may float when CE inactive
5	SDO	Serial Data Output pin; push-pull; high-impedance when not driving; can be connected to SDI for single-wire data line.
6	V _{SS}	Ground
7	CE	Chip Enable input; active HIGH; with internal pull-down
8	INT	Interrupt output pin; open-drain; active LOW
9	NC	Not Connected
10	CLKOE	CLKOUT enable/disable pin; enable is active HIGH

Real Time Clock Module with SPI Bus

AB-RTCMC-32.768kHz-ZIZE-S2



RoHS/RoHS II compliant

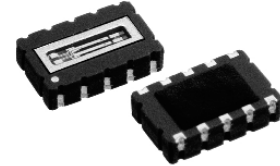

5.0 x 3.2 x 1.2 mm

BLOCK DIAGRAM:

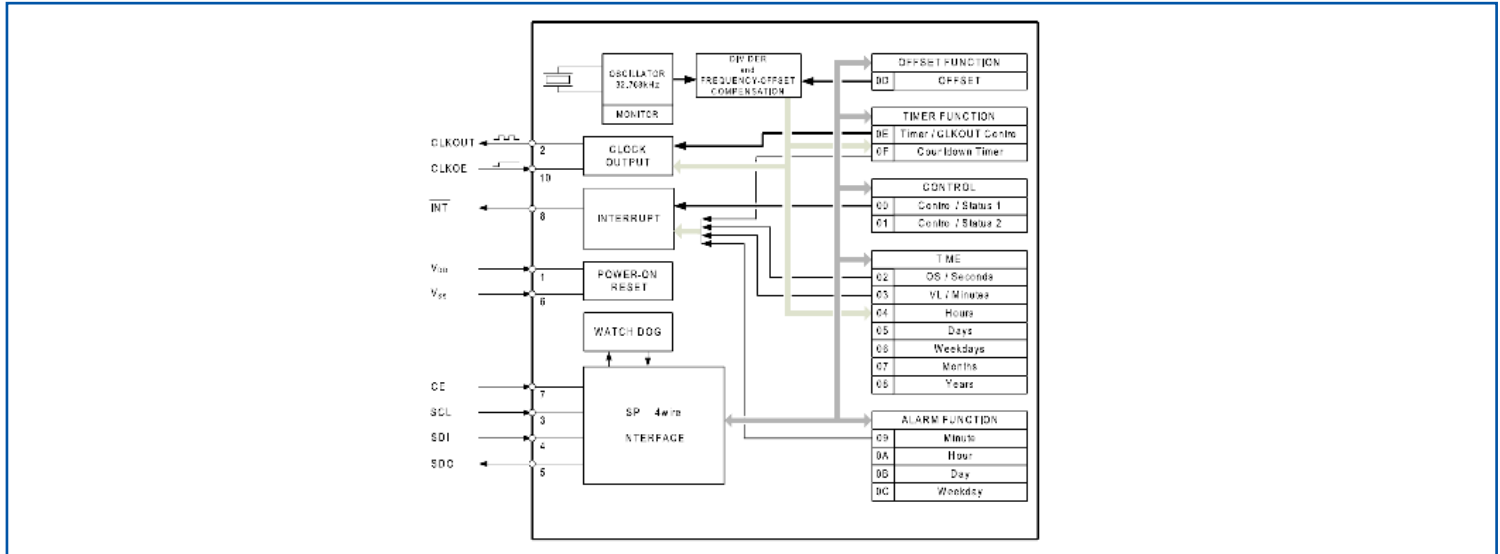

RECOMMENDED REFLOW PROFILE:

Maximum Reflow Conditions in accordance with IPC/JEDEC J-STD-020C "Pb-free"

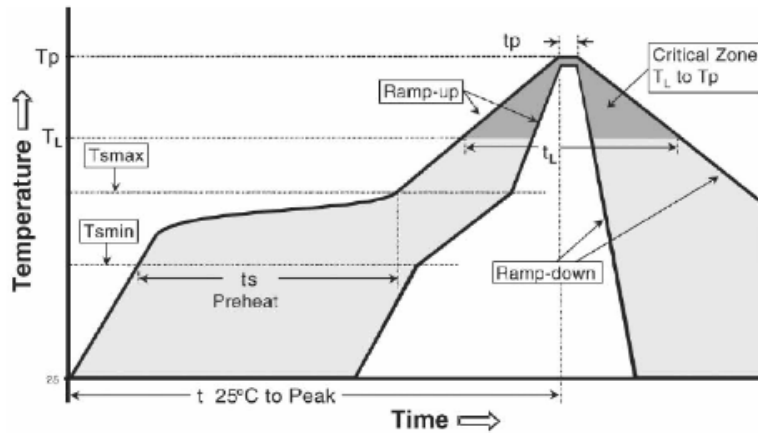

Temperature	Conditions	Units
Average Ramp-up Rate (T_{smax} to T_p)	3°C/second max	°C/s
Ramp Down Rate (T_{cool})	6°C/second max	°C/s
Time 25°C to Peak Temperature ($T_{to-peak}$)	8 minutes max	m
Preheat		
Temperature Min (T_{smin})	150	°C
Temperature Max (T_{smax})	200	°C
Time T_{smin} to T_{smax} (t_s)	60 ~ 180	sec
Time Above Liquidus		
Temperature Liquidus (T_L)	217	°C
Time above Liquidus (t_L)	60 ~ 150	sec
Peak Temperature		
Peak Temperature (T_p)	260	°C
Time within 5°C of Peak Temperature (t_p)	20 ~ 40	sec

Real Time Clock Module with SPI Bus

AB-RTCMC-32.768kHz-ZIZE-S2



RoHS/RoHS II compliant

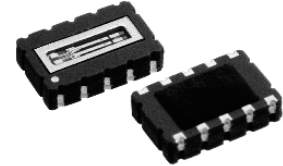

5.0 x 3.2 x 1.2 mm

TAPE & REEL:

T = 1000pcs/reel

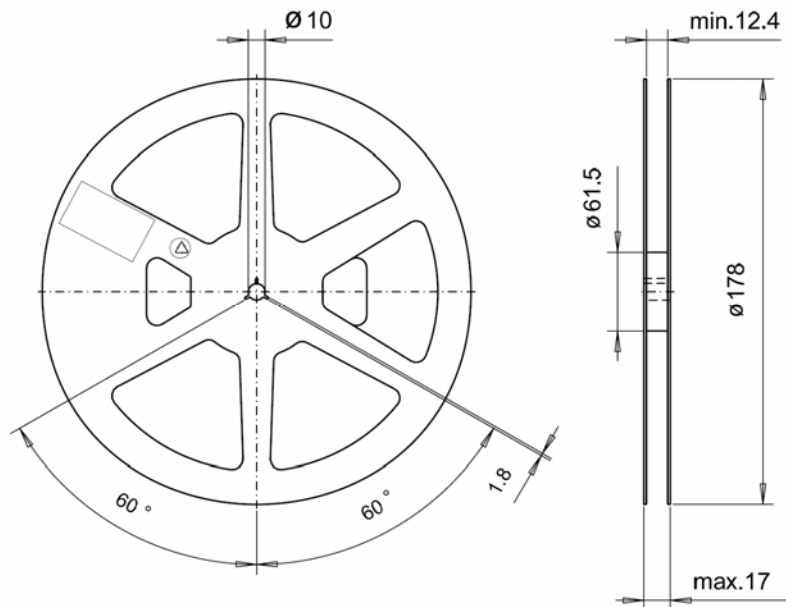
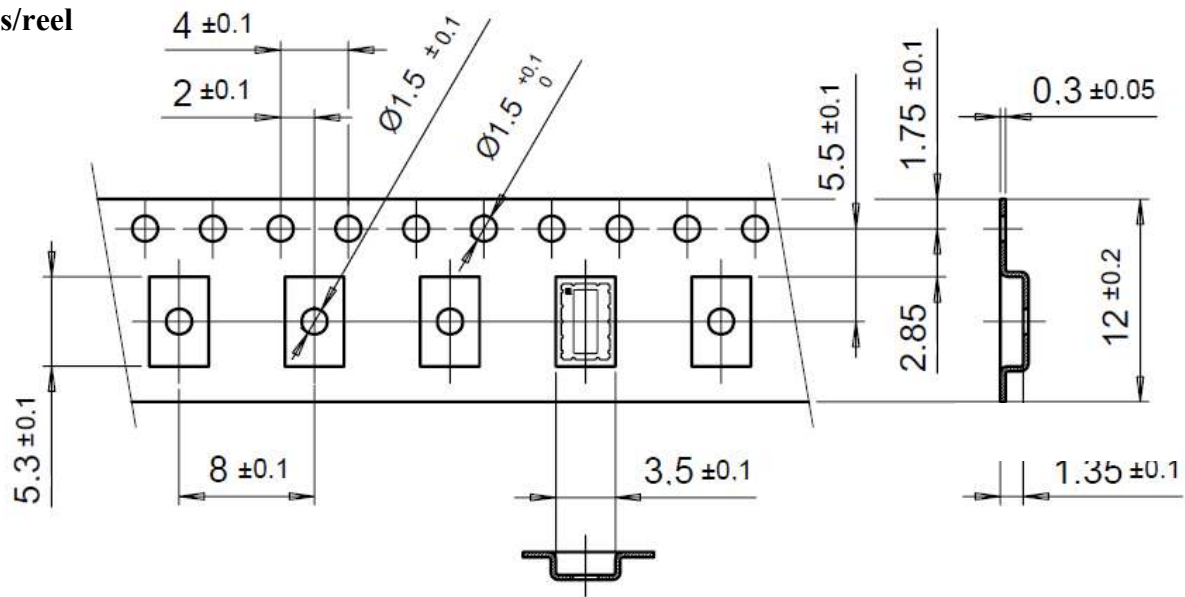

Dimension: mm

ATTENTION: Abracon Corporation's products are COTS – Commercial-Off-The-Shelf products; suitable for Commercial, Industrial and, where designated, Automotive Applications. Abracon's products are not specifically designed for Military, Aviation, Aerospace, Life-dependant Medical applications or any application requiring high reliability where component failure could result in loss of life and/or property. For applications requiring high reliability and/or presenting an extreme operating environment, written consent and authorization from Abracon Corporation is required. Please contact Abracon Corporation for more information.



5101 Hidden Creek Ln Spicewood TX 78669
Phone: 512-371-6159 | Fax: 512-351-8858
For terms and conditions of sales, please visit:
www.abracon.com

REVISED: 11.28.2018

ABRACON IS
ISO9001-2015
CERTIFIED