

THIS DRAWING IS UNPUBLISHED. RELEASED FOR PUBLICATION  
 © COPYRIGHT BY TYCO ELECTRONICS CORPORATION. ALL RIGHTS RESERVED.

LOC	DIST	REVISIONS					
G	14	P	LTR	DESCRIPTION	DATE	DWN	APVD
		D		REV PER 0G3A-0640-04	13AUG04	JR	TM

<b>AMP</b> WIRE RANGE	Listed FILE E13288	LR7189 Certified
22-16 AWG SOLID OR STRANDED	22-16 AWG SOLID OR STRANDED	22-16 AWG SOLID OR STRANDED

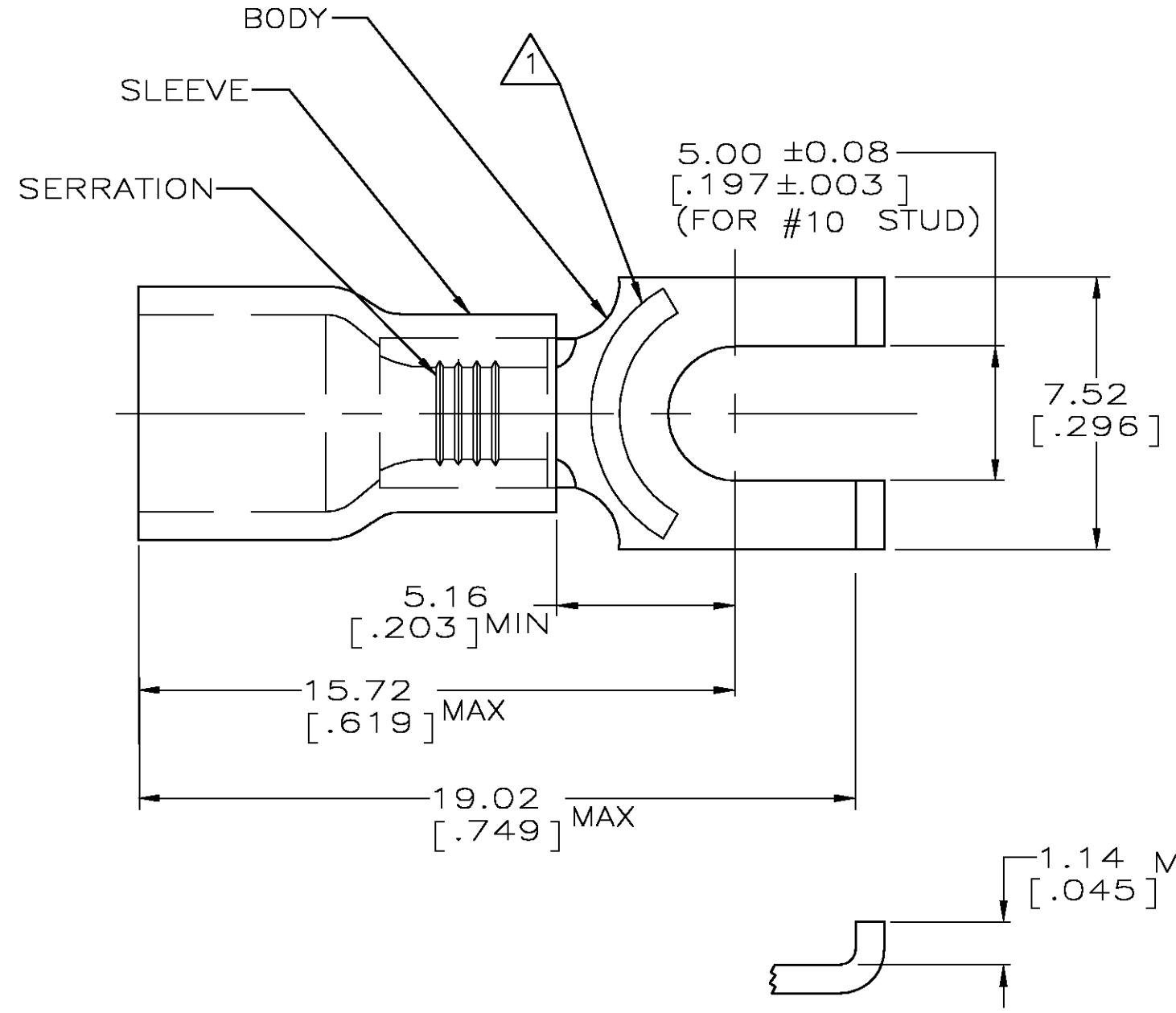

- ① STAMP AMP 22-18\* APPROX AS SHOWN  
22-16 TERMINALS ARE STAMPED 22-18 IN  
ACCORDANCE WITH MILITARY SPEC MIL-T-7928  
COMMERCIAL WIRE RANGE IS 22-16
- 2. WIRE INSUL DIA, 2.67-3.56 [.105-.140]
- 3. TONGUE MATL THK, 0.79±0.05 [.031±.002]
- ④ MATERIAL: BODY - CU PER ASTM B152  
SLEEVE - PVC, COLOR - RED

100	LOOSE PIECE, BOX	8-328516-1
5000	ON TAPE, REEL	2-328516-1
1000	LOOSE PIECE	328516
QTY	PACKAGE TYPE	PART NO

**AMP INCORPORATED**  
**CUSTOMER SERVICE SYSTEMS**

FOR ADDITIONAL PRODUCT INFORMATION OR COPIES OF DRAWINGS AND TECHNICAL DOCUMENTS  
 PRODUCT INFORMATION CENTER  
 1-800-522-6752

FOR APPLICATION TOOLING INFORMATION  
 TOOLING ASSISTANCE CENTER  
 1-800-722-1111

FOR ORDER ENTRY  
 1-800-526-5142

MAX RECOMMENDED OPERATING TEMPERATURE:  
 105°C [221°F]

VOLTAGE RATING:  
 600V MAX  
 (1000V FIXTURE OR SIGN)

CIRCULAR MIL AREA:  
 0.26-1.65mm² [509-3260]  
 SOLID OR STRANDED

THIS DRAWING IS A CONTROLLED DOCUMENT.

DIMENSIONS: mm [INCHES]

TOLERANCES UNLESS OTHERWISE SPECIFIED:

0 PLC	± -
1 PLC	± -
2 PLC	± 0.20 [.008]
3 PLC	± -
4 PLC	± -
ANGLES	± -

MATERIAL: 4  
 TIN PER ASTM B545

DWN L OLMEDA 05SEP95  
 CHK M ELLIS 05SEP95  
 APVD G NGO 05SEP95

**tyco**  
**Electronics**  
 Tyco Electronics Corporation  
 Harrisburg, Pa 17105-3608

NAME: TERMINAL, SPADE, FLANGED, PLASTI-GRIP, WIRE SIZE: 22-16 AWG

SIZE: A3 CAGE CODE: 00779 DRAWING NO: C-328516 RESTRICTED TO: -

WEIGHT: -

CUSTOMER DRAWING SCALE: 6:1 SHEET 1 OF 1 REV D