

## **DESCRIPTION**

The AP63300/AP63301 is 3A, synchronous buck converter with a wide input voltage range of 3.8V to 32V. The device fully integrates a 75mΩ high-side power MOSFET and a 40mΩ low-side power MOSFET to provide high-efficiency step-down DC-DC conversion.

The AP63300/AP63301 device is easily used by minimizing the external component count due to its adoption of peak current mode control along with its integrated loop compensation network.

The AP63300/AP63301 design is optimized for Electromagnetic Interference (EMI) reduction. The device has a proprietary gate driver scheme to resist switching node ringing without sacrificing MOSFET turn-on and turn-off times, which reduces high-frequency radiated EMI noise caused by MOSFET switching. AP63300 also features Frequency Spread Spectrum (FSS) with a switching frequency jitter of  $\pm 6\%$ , which reduces EMI by not allowing emitted energy to stay in any one frequency for a significant period of time. The device is available in a TSOT26 package.

## **FEATURES**

- VIN 3.8V to 32V
- 3A Continuous Output Current
- 0.8V  $\pm$  1% Reference Voltage
- 22μA Ultralow Quiescent Current (Pulse Frequency Modulation)
- 500kHz Switching Frequency
- Supports Pulse Frequency Modulation (PFM)
  - AP63300
  - Up to 88% Efficiency at 5mA Light Load
- Pulse Width Modulation (PWM) Regardless of Output Load
  - AP63301
- Proprietary Gate Driver Design for Best EMI Reduction
- Frequency Spread Spectrum (FSS) to Reduce EMI
  - AP63300
- Low-Dropout (LDO) Mode
- Precision Enable Threshold to Adjust UVLO
- Protection Circuitry
  - Undervoltage Lockout (UVLO)
  - Output Overvoltage Protection (OVP)
  - Cycle-by-Cycle Peak Current Limit
  - Thermal Shutdown

**APPLICATIONS**

- 5V, 12V, and 24V Distributed Power Bus Supplies
- FPGA, DSP, and ASIC Supplies
- Flat Screen TV Sets and Monitors
- White Goods and Small Home Appliances
- Home Audio
- Network Systems
- Consumer Electronics
- Cordless Power Tools
- Optical Communication and Networking Systems
- General Purpose Point of Load

**FUNCTIONAL BLOCK**

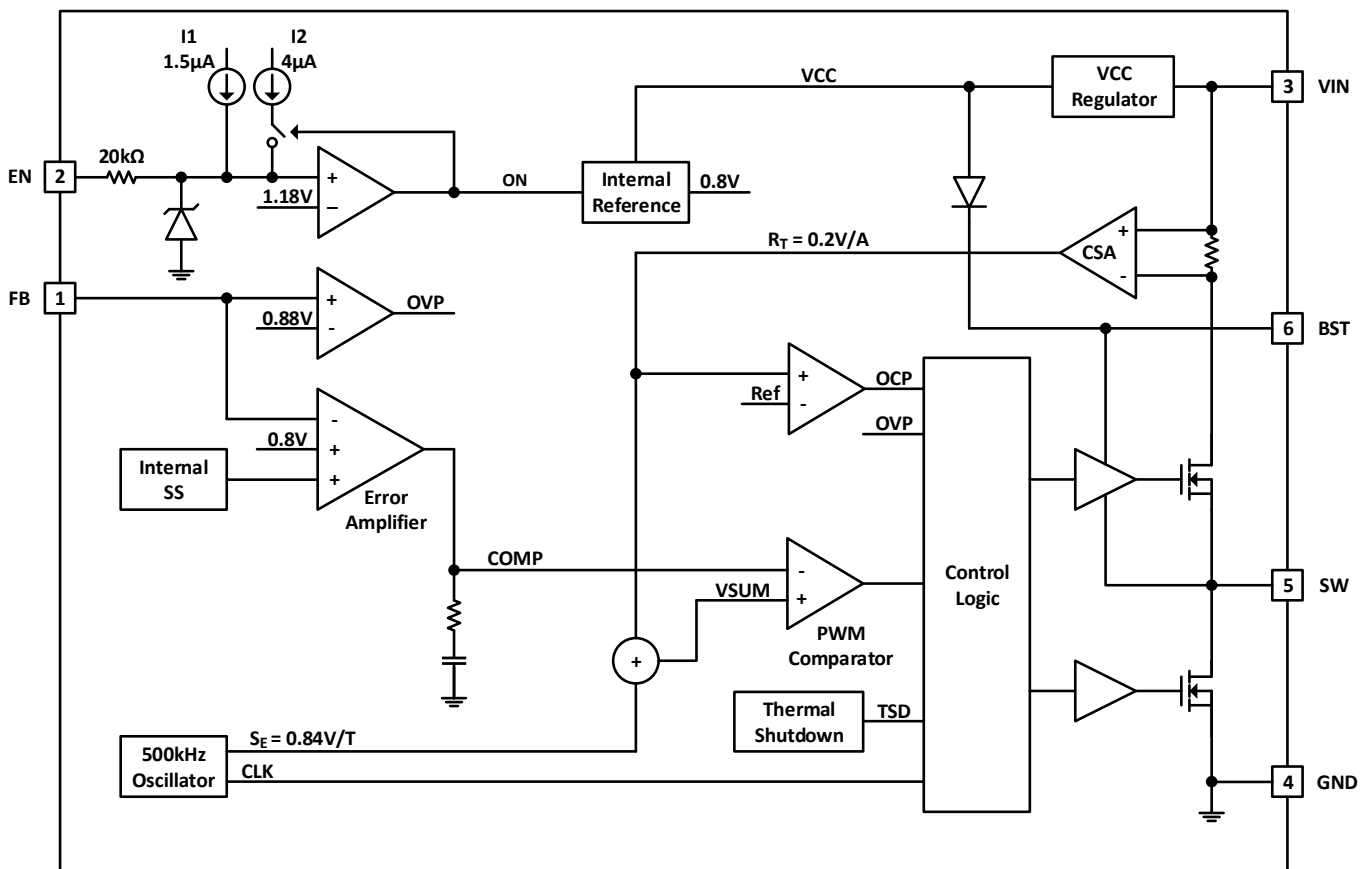

**Figure 1. Functional Block Diagram**

### ABSOLUTE MAXIMUM RATINGS

Symbol	Parameter	Rating	Unit
VIN	Supply Pin Voltage	-0.3 to +35.0 (DC)	V
		-0.3 to +40.0 (400ms)	
VFB	Feedback Voltage	-0.3V to +6.0	V
VEN	Enable/UVLO Pin Voltage	-0.3 to +35.0	V
VSW	Switch Node Voltage	-0.3 to VIN + 0.3 (DC)	V
		-2.5 to VIN + 2.0 (20ns)	V
VBST	Bootstrap Pin Voltage	VSW - 0.3 to VSW + 6.0	V
TST	Storage Temperature	-65 to +150	°C
TJ	Junction Temperature	+160	°C
TL	Lead Temperature	+260	°C
<b>ESD Susceptibility (Note 5)</b>			
HBM	Human Body Mode	2000	V
CDM	Charged Device Model	1000	V

### RECOMMENDED OPERATING CONDITIONS

Symbol	Parameter	Min	Max	Unit
VIN	Supply Voltage	3.8	32	V
VOOUT	Output Voltage	0.8	31	V
TA	Operating Ambient Temperature Range	-40	+85	°C
TJ	Operating Junction Temperature Range	-40	+125	°C

**EVALUATION BOARD**

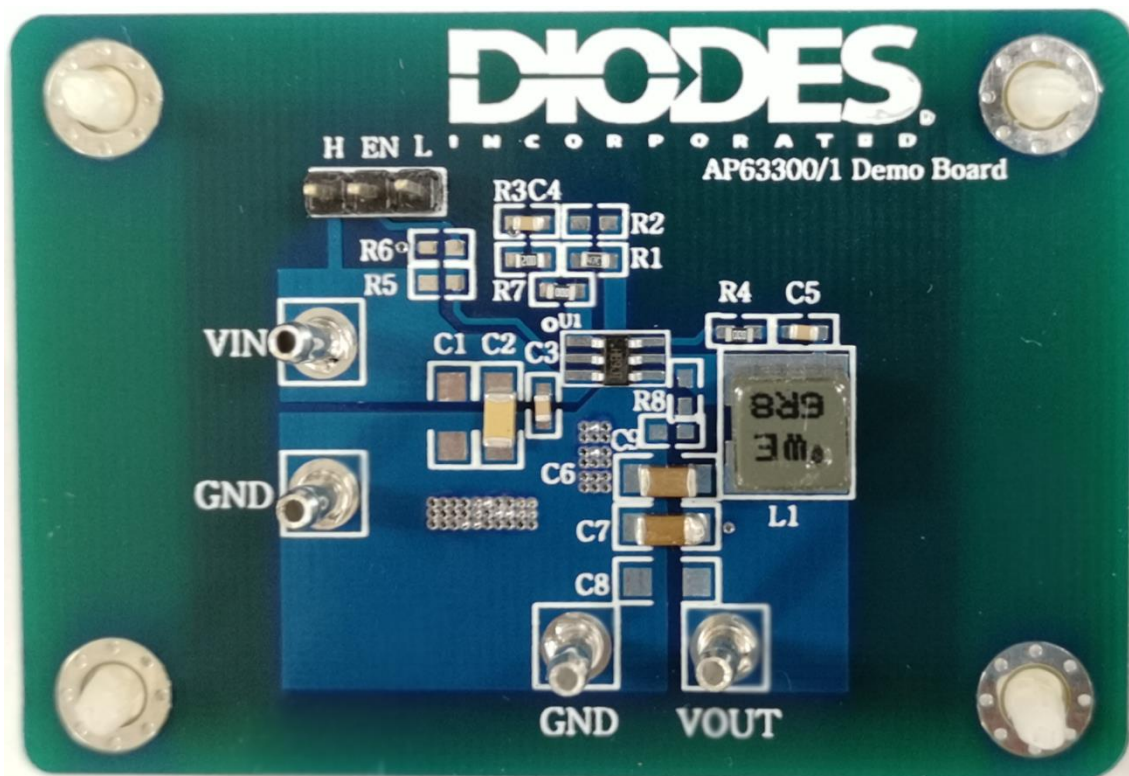

**Figure 2. Top Picture of EV Board**

**QUICK START GUIDE**

The AP63300-EVM has a simple layout and allows access to the appropriate signals through test points. To evaluate the performance of the AP63300, follow the procedure below:

1. For evaluation board configured at  $V_{OUT}=5V$ , connect a power supply to the input terminals  $V_{IN}$  and GND. Set  $V_{IN}$  to 12V.
2. Connect the positive terminal of the electronic load to  $V_{OUT}$  and negative terminal to GND.
3. For Enable, place a jumper to “H” position to enable IC. Jump to “L” position to disable IC.
4. The evaluation board should now power up with a 5V output voltage.
5. Check for the proper output voltage of 5V ( $\pm 1\%$ ) at the output terminals  $V_{OUT}$  and GND. Measurement can also be done with a multimeter with the positive and negative leads between  $V_{OUT}$  and GND.
6. Set the load to 3A through the electronic load. Check for the stable operation of the SW signal on the oscilloscope. Measure the switching frequency.

### MEASUREMENT/PERFORMANCE GUIDELINES:

- 1) When measuring the output voltage ripple, maintain the shortest possible ground lengths on the oscilloscope probe. Long ground leads can erroneously inject high frequency noise into the measured ripple.
- 2) For efficiency measurements, connect an ammeter in series with the input supply to measure the input current. Connect an electronic load to the output for output current.

### Setting the Output Voltage of AP63300

- 1) Setting the output voltage

The AP63300 features external programmable output voltage by using a resistor divider network R3 and R1 as shown in the typical application circuit. The output voltage is calculated as below,

$$V_{OUT} = 0.8 \times \left( \frac{R_1 + R_3}{R_1} \right)$$

First, select a value for R1 according to the value recommended in the table 1. Then, R3 is determined. The output voltage is given by Table 1 for reference. For accurate output voltage, 1% tolerance is required.

- 2) Output feed-forward capacitor selection

The AP63300 has the internal integrated loop compensation as shown in the function block diagram. The compensation network includes a 18k resistor and a 7.6nF capacitor. Usually, the type II compensation network has a phase margin between 60 and 90 degree. However, if the output capacitor has ultra-low ESR, the converter results in low phase margin. To increase the converter phase margin, a feed-forward cap C4 is used to boost the phase margin at the converter cross-over frequency  $f_c$ . The feed-forward capacitor is given by Table 1 for reference. The feed-forward capacitor is calculated as below,

$$C_{ff} = \frac{1}{2\pi \times f_c \times R_3}$$

Table 1. Resistor selection for output voltage setting

Vo	R3	R1	C4	C6-C8
1.8V	77.5 KΩ	62 KΩ	100pF	22uFx2
2.5V	131 KΩ	62 KΩ	100pF	22uFx2
3.3V	182 KΩ	62 KΩ	100 pF	22uFx2
5V	157 KΩ	30 KΩ	100 pF	22uFx2
12V	249 KΩ	18 KΩ	56 pF	22uFx4

**EXTERNAL COMPONENT SELECTION:**

- 1) Input & output Capacitors (C<sub>in</sub>, C<sub>out</sub>)
  - (1) For lower output ripple, low ESR is required.
  - (2) Low leakage current needed, X5R/X7R ceramic recommend, multiple capacitor parallel connection.
  - (3) The C<sub>in</sub> and C<sub>out</sub> capacitances are greater than 22uF and 44uF respective.
- 2) Bootstrap Voltage Regulator
  - (1) An external 0.1uF ceramic capacitor is required as bootstrap capacitor between BST and SW pin to work as high side power MOSFET gate driver.
- 3) Inductor (L)
  - (1) Low DCR for good efficiency
  - (2) Inductance saturate current must higher than the output current
  - (3) The recommended inductance is shown in the table 2 below.

**EVALUATION BOARD SCHEMATIC**

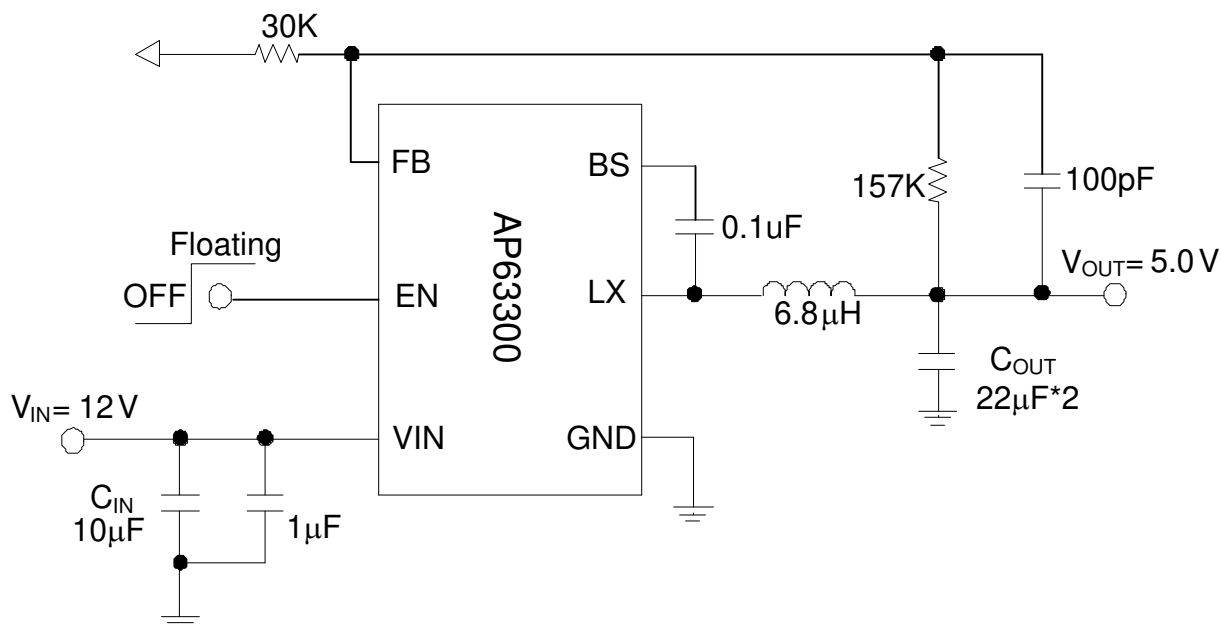

**Figure 3. Typical Application Circuit**

**PCB TOP LAYOUT**

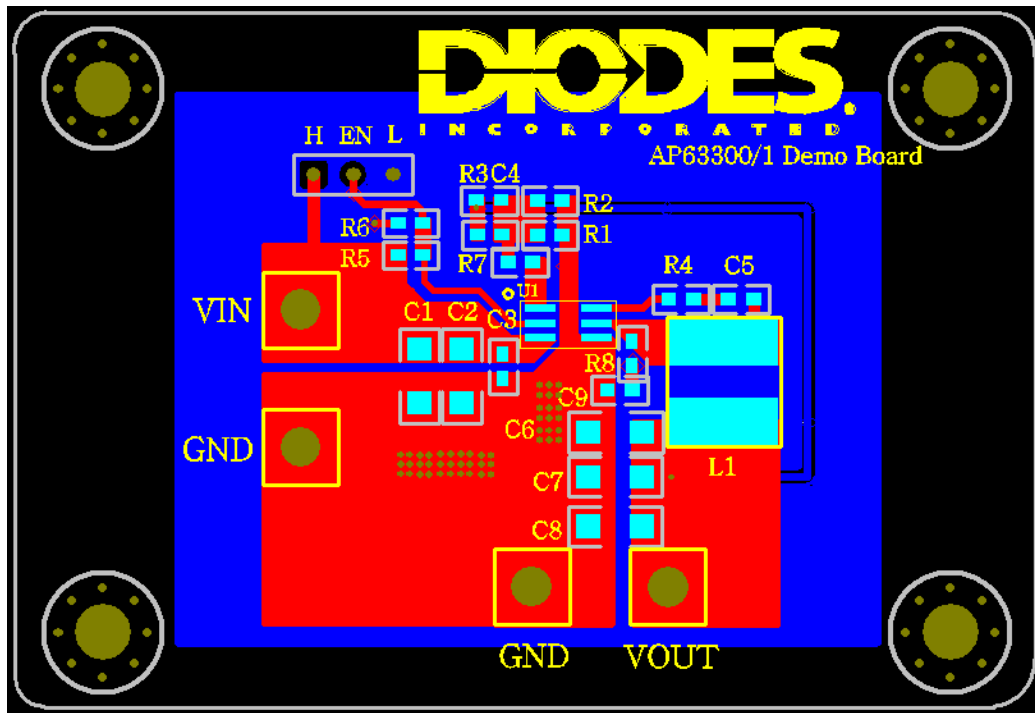

Figure 4. AP63300/1-EVM – Top Layer

**PCB BOTTOM LAYOUT**

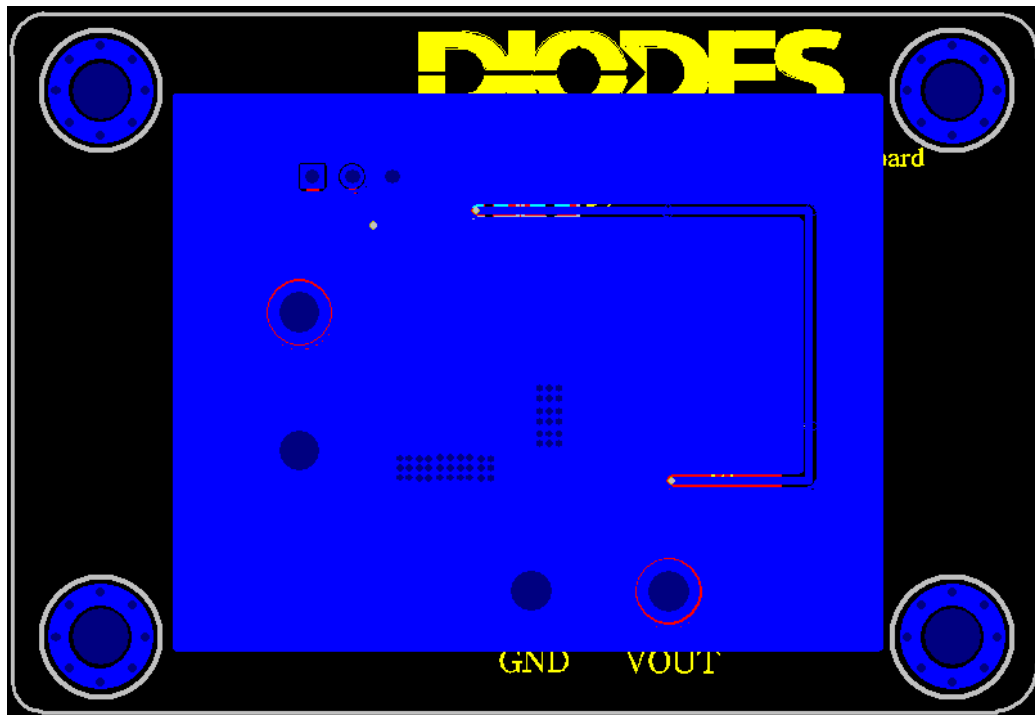

Figure 5. AP63300/1 -EVM – Bottom Layer

### BILL OF MATERIALS for AP63300/1-EVM

Item	Value	Type	Rating	Description	Description
C2	22uF	X5R/X7R, Ceramic/1206	35V	Input CAP	
C3	0.1uF	X5R/X7R, Ceramic/0603	50V	Input CAP	Würth PART 885 012 206 095
C4	100pF	0603	100V	Feedback CAP	Würth PART 885 012 206 102
C5	0.1uF	X5R/X7R, Ceramic/0603	50V	Bootstrap CAP	Würth PART 885 012 206 095
C6 & C7	22uF	X5R/X7R, Ceramic/1206	25V	Output CAP	
L1	6.8uH	6060	6.5A	Inductor	Würth PART 744 393 690 68
R1	30K	0603	1%	Voltage set RES*	
R3	162K	0603	1%		
R4 & R7	0	0603	1%		Bootstrap RES
U1		AP63300		TSOT23-6	Diodes BCD

\*Note: The present value of R3/R1 are based on  $V_{out}=5.0V$



**TYPICAL PERFORMANCE CHARACTERISTICS**

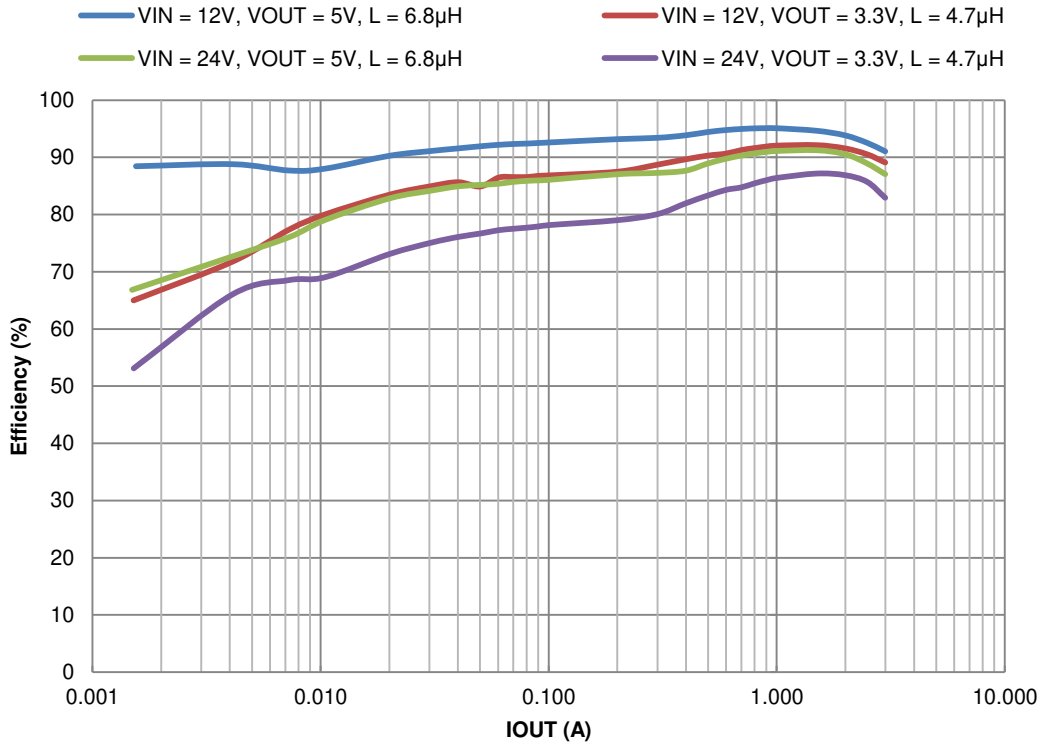

**Figure 5. AP63300 Efficiency vs. Output Current**

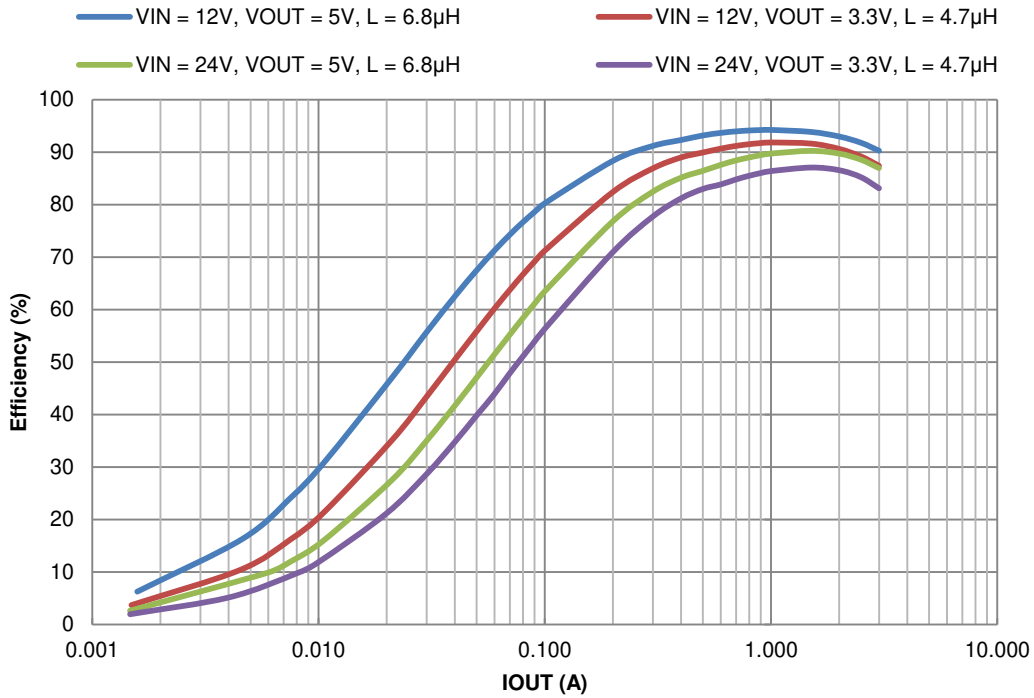

**Figure 6. AP63301 Efficiency vs. Output Current**

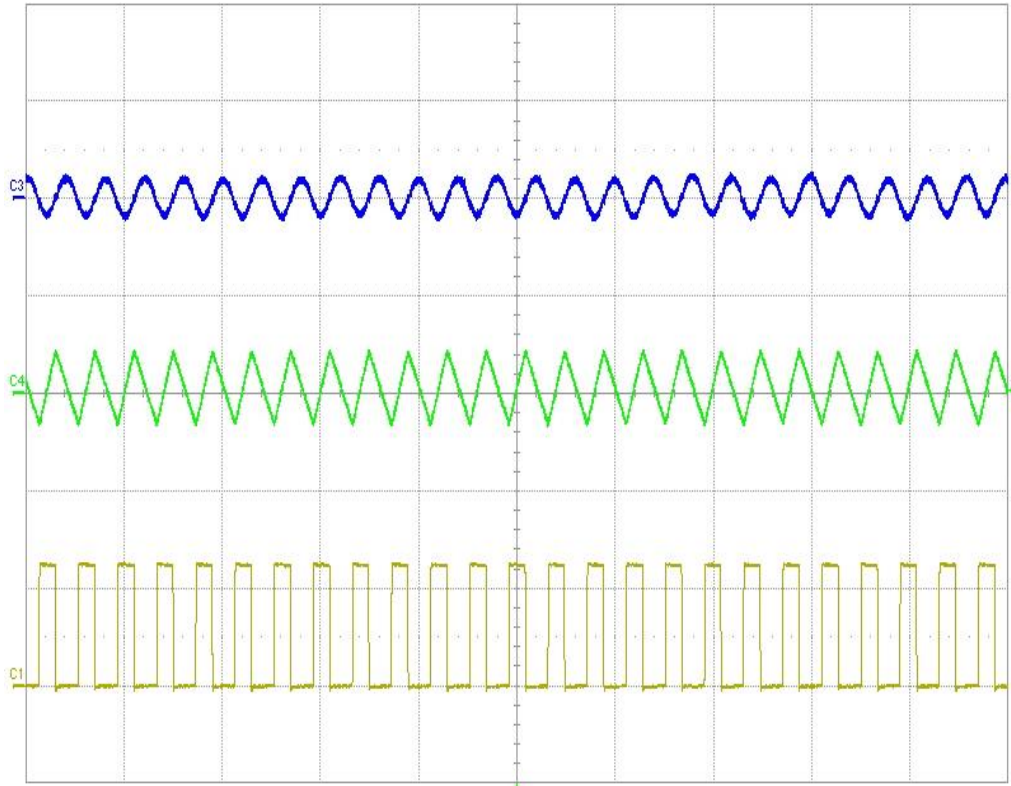

Figure 7. AP63301 Vin=12 Vout=5V Output Voltage Ripple, IOU = 50mA

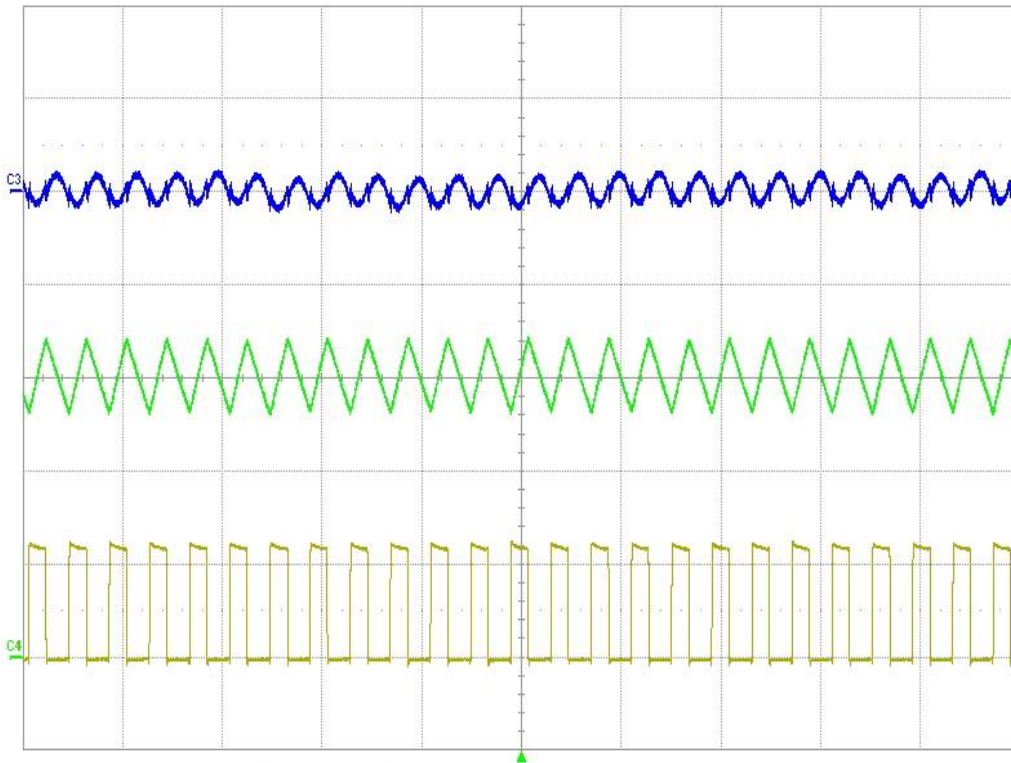

Figure 8. AP63301 Vin=12 Vout=5V Output Voltage Ripple, IOU = 3A

**IMPORTANT NOTICE**

DIODES INCORPORATED MAKES NO WARRANTY OF ANY KIND, EXPRESS OR IMPLIED, WITH REGARDS TO THIS DOCUMENT, INCLUDING, BUT NOT LIMITED TO, THE IMPLIED WARRANTIES OF MERCHANTABILITY AND FITNESS FOR A PARTICULAR PURPOSE (AND THEIR EQUIVALENTS UNDER THE LAWS OF ANY JURISDICTION).

Diodes Incorporated and its subsidiaries reserve the right to make modifications, enhancements, improvements, corrections or other changes without further notice to this document and any product described herein. Diodes Incorporated does not assume any liability arising out of the application or use of this document or any product described herein; neither does Diodes Incorporated convey any license under its patent or trademark rights, nor the rights of others. Any Customer or user of this document or products described herein in such applications shall assume all risks of such use and will agree to hold Diodes Incorporated and all the companies whose products are represented on Diodes Incorporated website, harmless against all damages.

Diodes Incorporated does not warrant or accept any liability whatsoever in respect of any products purchased through unauthorized sales channel. Should Customers purchase or use Diodes Incorporated products for any unintended or unauthorized application, Customers shall indemnify and hold Diodes Incorporated and its representatives harmless against all claims, damages, expenses, and attorney fees arising out of, directly or indirectly, any claim of personal injury or death associated with such unintended or unauthorized application.

Products described herein may be covered by one or more United States, international or foreign patents pending. Product names and markings noted herein may also be covered by one or more United States, international or foreign trademarks.

This document is written in English but may be translated into multiple languages for reference. Only the English version of this document is the final and determinative format released by Diodes Incorporated.

**LIFE SUPPORT**

Diodes Incorporated products are specifically not authorized for use as critical components in life support devices or systems without the express written approval of the Chief Executive Officer of Diodes Incorporated. As used herein:

A. Life support devices or systems are devices or systems which:

1. are intended to implant into the body, or
2. support or sustain life and whose failure to perform when properly used in accordance with instructions for use provided in the labeling can be reasonably expected to result in significant injury to the user.

B. A critical component is any component in a life support device or system whose failure to perform can be reasonably expected to cause the failure of the life support device or to affect its safety or effectiveness.

Customers represent that they have all necessary expertise in the safety and regulatory ramifications of their life support devices or systems, and acknowledge and agree that they are solely responsible for all legal, regulatory and safety-related requirements concerning their products and any use of Diodes Incorporated products in such safety-critical, life support devices or systems, notwithstanding any devices- or systems-related information or support that may be provided by Diodes Incorporated. Further, Customers must fully indemnify Diodes Incorporated and its representatives against any damages arising out of the use of Diodes Incorporated products in such safety-critical, life support devices or systems.

Copyright © 2019, Diodes Incorporated

[www.diodes.com](http://www.diodes.com)