

### FEATURES

Improved Replacement for Signetics SE/NE5539

### AC PERFORMANCE

Gain Bandwidth Product: 1.4 GHz typ

Unity Gain Bandwidth: 220 MHz typ

High Slew Rate: 600 V/ $\mu$ s typ

Full Power Response: 82 MHz typ

Open-Loop Gain: 47 dB min, 52 dB typ

### DC PERFORMANCE

All Guaranteed DC Specifications Are 100% Tested  
For Each Device Over Its Full Temperature  
Range – For All Grades and Packages

$V_{os}$ : 5 mV max Over Full Temperature Range  
(AD5539S)

$I_B$ : 20  $\mu$ A max (AD5539J)

CMRR: 70 dB min, 85 dB typ

PSRR: 100  $\mu$ V/V typ

MIL-STD-883B Parts Available

### PRODUCT DESCRIPTION

The AD5539 is an ultrahigh frequency operational amplifier designed specifically for use in video circuits and RF amplifiers. Requiring no external compensation for gains greater than 5, it may be operated at lower gains with the addition of external compensation.

As a superior replacement for the Signetics NE/SE5539, each AD5539 is 100% dc tested to meet all of its guaranteed dc specifications over the full temperature range of the device.

The high slew rate and wide bandwidth of the AD5539 provide low cost solutions to many otherwise complex and expensive high frequency circuit design problems.

The AD5539 is available specified to operate over either the commercial (AD5539JN/JQ) or military (AD5539SQ) temperature range. The commercial grade is available either in 14-pin plastic or cerdip packages. The military version is supplied in the cerdip package. Chip versions are also available.

### CONNECTION DIAGRAM

Plastic DIP (N) Package  
or Cerdip (Q) Package

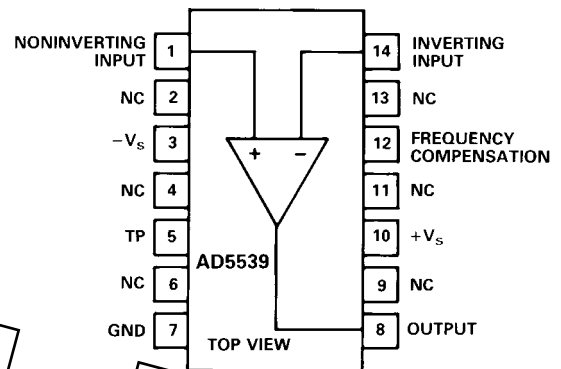

### PRODUCT HIGHLIGHTS

1. All guaranteed dc specifications are 100% tested.
2. The AD5539 drives 50  $\Omega$  and 75  $\Omega$  loads directly.
3. Input voltage noise is less than 4 nV/ $\sqrt{\text{Hz}}$ .
4. Low cost RF and video speed performance.
5.  $\pm 2$  volt output range into a 150  $\Omega$  load.
6. Low cost.
7. Chips available.

### REV. B

Information furnished by Analog Devices is believed to be accurate and reliable. However, no responsibility is assumed by Analog Devices for its use, nor for any infringements of patents or other rights of third parties which may result from its use. No license is granted by implication or otherwise under any patent or patent rights of Analog Devices.

# AD5539—SPECIFICATIONS (@ +25°C and $V_S = \pm 8$ V dc, unless otherwise noted)

Parameter	AD5539J			AD5539S			Units
	Min	Typ	Max	Min	Typ	Max	
<b>INPUT OFFSET VOLTAGE</b>							
Initial Offset <sup>1</sup>		2	5		2	3	mV
$T_{MIN}$ to $T_{MAX}$			6			5	mV
<b>INPUT OFFSET CURRENT</b>							
Initial Offset <sup>2</sup>		0.1	2		0.1	1	$\mu$ A
$T_{MIN}$ to $T_{MAX}$			5			3	$\mu$ A
<b>INPUT BIAS CURRENT</b>							
Initial <sup>2</sup>							
$V_{CM} = 0$		6	20		6	13	$\mu$ A
Either Input							
$T_{MIN}$ to $T_{MAX}$			40			25	$\mu$ A
<b>FREQUENCY RESPONSE</b>							
$R_L = 150 \Omega^3$							
Small Signal Bandwidth		220			220		MHz
$A_{CL} = 2^4$							
Gain Bandwidth Product		1400			1400		MHz
$A_{CL} = 26$ dB							
Full Power Response							
$A_{CL} = 2^4$		68			68		MHz
$A_{CL} = 7$		82			82		MHz
$A_{CL} = 20$		65			65		MHz
Settling Time (1%)		12			12		ns
Slew Rate		600			600		V/ $\mu$ s
Large Signal Propagation Delay		4			4		ns
Total Harmonic Distortion							
$R_L = \infty$		0.010			0.010		%
$R_L = 100 \Omega^3$		0.016			0.016		%
$V_{OUT} = 2$ V p-p							
$A_{CL} = 7, f = 1$ kHz							
<b>INPUT IMPEDANCE</b>							
		100			100		k $\Omega$
<b>OUTPUT IMPEDANCE (<math>f &lt; 10</math> MHz)</b>							
		2			2		$\Omega$
<b>INPUT VOLTAGE RANGE</b>							
Differential <sup>5</sup>							
(Max Nondestructive)		250			250		mV
Common-Mode Voltage							
(Max Nondestructive)		2.5			2.5		V
Common-Mode Rejection Ratio							
$\Delta V_{CM} = 1.7$ V							
$R_S = 100 \Omega$	<b>70</b>	85		<b>70</b>	85		dB
$T_{MIN}$ to $T_{MAX}$	<b>60</b>			<b>60</b>			dB
<b>INPUT VOLTAGE NOISE</b>							
Wideband RMS Noise (RTI)		5			5		FV
BW = 5 MHz; $R_S = 50 \Omega$							
Spot Noise		4			4		nV/ $\sqrt{\text{Hz}}$
F = 1 kHz; $R_S = 50 \Omega$							
<b>OPEN-LOOP GAIN</b>							
$V_O = +2.3$ V, $-1.7$ V							
$R_L = 150 \Omega^3$	<b>47</b>	52	<b>58</b>	<b>47</b>	52	<b>58</b>	dB
$R_L = 2$ k $\Omega$	<b>47</b>		<b>58</b>	<b>48</b>		<b>57</b>	dB
$T_{MIN}$ to $T_{MAX}$ $-R_L = 2$ k $\Omega$	<b>43</b>		<b>63</b>	<b>46</b>		<b>60</b>	dB

Parameter	AD5539J			AD5539S			Units
	Min	Typ	Max	Min	Typ	Max	
<b>OUTPUT CHARACTERISTICS</b>							
Positive Output Swing							
$R_L = 150 \Omega^3$	+2.3	+2.8		+2.3	+2.8		V
$R_L = 2 \text{ k}\Omega$	+2.3	+3.3		+2.5	+3.3		V
$T_{\text{MIN}}$ to $T_{\text{MAX}}$ with $R_L = 2 \text{ k}\Omega$	+2.3			+2.3			V
Negative Output Swing							
$R_L = 150 \Omega^3$		-2.2	<b>-1.7</b>		-2.2	<b>-1.7</b>	V
$R_L = 2 \text{ k}\Omega$		-2.9	<b>-1.7</b>		-2.9	<b>-2.0</b>	V
$T_{\text{MIN}}$ to $T_{\text{MAX}}$ with $R_L = 2 \text{ k}\Omega$			<b>-1.5</b>			<b>-1.5</b>	V
<b>POWER SUPPLY (No Load, No Resistor to <math>-V_S</math>)</b>							
Rated Performance		$\pm 8$			$\pm 8$		V
Operating Range	<b><math>\pm 4.5</math></b>		<b><math>\pm 10</math></b>	<b><math>\pm 4.5</math></b>		<b><math>\pm 10</math></b>	V
Quiescent Current							
Initial $I_{\text{CC}+}$		14	<b>18</b>		14	<b>17</b>	mA
$T_{\text{MIN}}$ to $T_{\text{MAX}}$			<b>20</b>			<b>18</b>	mA
Initial $I_{\text{CC}-}$		11	<b>15</b>		11	<b>14</b>	mA
$T_{\text{MIN}}$ to $T_{\text{MAX}}$			<b>17</b>			<b>15</b>	mA
PSRR							
Initial		100	<b>1000</b>		100	<b>1000</b>	$\mu\text{V}/\text{V}$
$T_{\text{MIN}}$ to $T_{\text{MAX}}$			<b>2000</b>			<b>2000</b>	$\mu\text{V}/\text{V}$
<b>TEMPERATURE RANGE</b>							
Operating,							
Rated Performance							
Commercial ( $0^\circ\text{C}$ to $+70^\circ\text{C}$ )		AD5539JN, AD5539JQ					
Military ( $-55^\circ\text{C}$ to $+125^\circ\text{C}$ )					AD5539SQ		
<b>PACKAGE OPTIONS</b>							
Plastic (N-14)		AD5539JN			AD5539SQ, AD5539SQ/883B		
Cerdip (Q-14)		AD5539JQ					
J and S Grade Chips Available							

**NOTES**

<sup>1</sup>Input Offset Voltage specifications are guaranteed after 5 minutes of operation at  $T_A = +25^\circ\text{C}$ .

<sup>2</sup>Bias Current specifications are guaranteed maximum at either input after 5 minutes of operation at  $T_A = +25^\circ\text{C}$ .

<sup>3</sup> $R_X = 470 \Omega$  to  $-V_S$ .

<sup>4</sup>Externally compensated.

<sup>5</sup>Defined as voltage between inputs, such that neither exceeds  $+2.5 \text{ V}$ ,  $-5.0 \text{ V}$  from ground.

Specifications subject to change without notice.

Specifications in **boldface** are tested on all production units at final electrical test. Results from those tests are used to calculate outgoing quality levels. All min and max specifications are guaranteed, although only those shown in boldface are tested on all production units.

# AD5539

## ABSOLUTE MAXIMUM RATINGS\*

Supply Voltage	±10 V
Internal Power Dissipation	550 mW
Input Voltage	+2.5 V, -5.0 V
Differential Input Voltage	0.25 V
Storage Temperature Range (Q)	-65°C to +150°C
Storage Temperature Range (N)	-65°C to +125°C
Operating Temperature Range	
AD5539JN	0°C to +70°C
AD5539JQ	0°C to +70°C
AD5539SQ	-55°C to +125°C
Lead Temperature Range (Soldering 60 Seconds)	+300°C

\*Stresses above those listed under "Absolute Maximum Ratings" may cause permanent damage to the device. This is a stress rating only and functional operation of the device at these or any other conditions above those indicated in the operational section of this specification is not implied. Exposure to absolute maximum rating conditions for extended periods may affect device reliability.

## OFFSET NULL CONFIGURATION

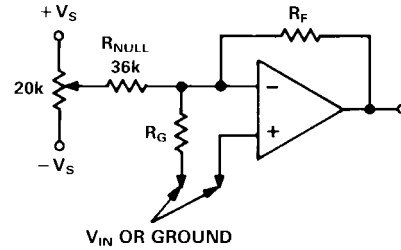

$$\text{OUTPUT NULL RANGE} \cong +V_S \left( \frac{R_F}{R_{NULL}} \right) \text{ TO } -V_S \left( \frac{R_F}{R_{NULL}} \right)$$

OFFSET NULL CONFIGURATION

OBSOLETE

## METALIZATION PHOTOGRAPH

Dimensions shown in inches and (mm).  
Contact factory for latest dimensions.

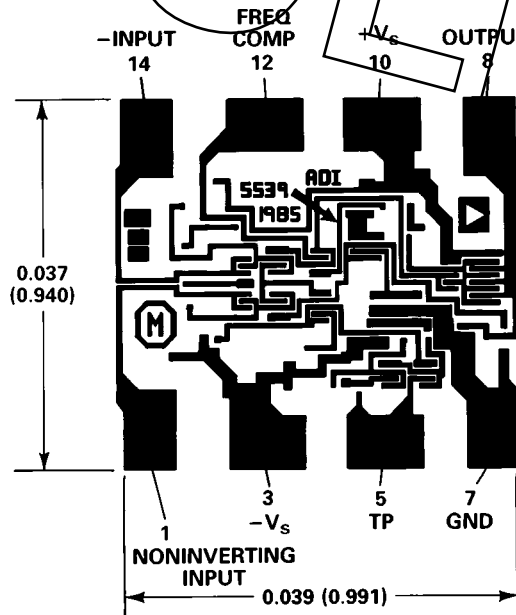

## CAUTION

ESD (electrostatic discharge) sensitive device. Electrostatic charges as high as 4000 V readily accumulate on the human body and test equipment and can discharge without detection. Although the AD5539 features proprietary ESD protection circuitry, permanent damage may occur on devices subjected to high energy electrostatic discharges. Therefore, proper ESD precautions are recommended to avoid performance degradation or loss of functionality.



# Typical Characteristics—AD5539

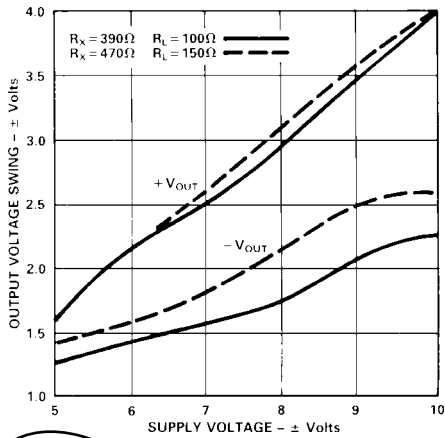

Figure 1. Output Voltage Swing vs. Supply Voltage

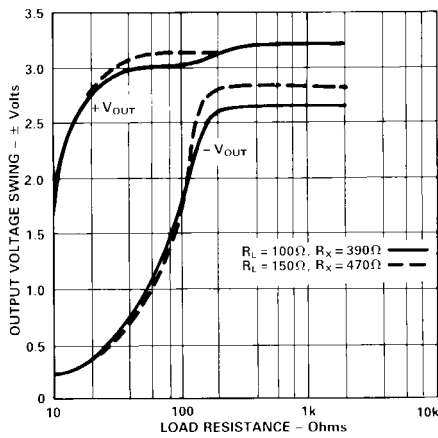

Figure 2. Output Voltage Swing vs. Load Resistance

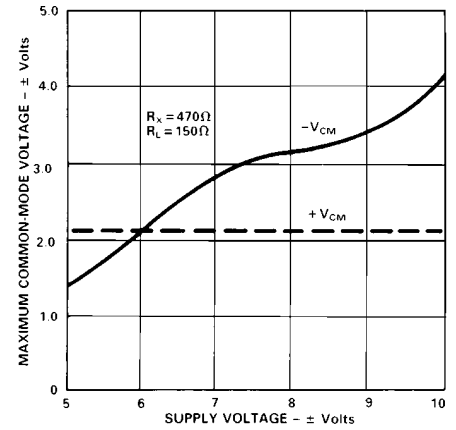

Figure 3. Maximum Common-Mode Voltage vs. Supply Voltage

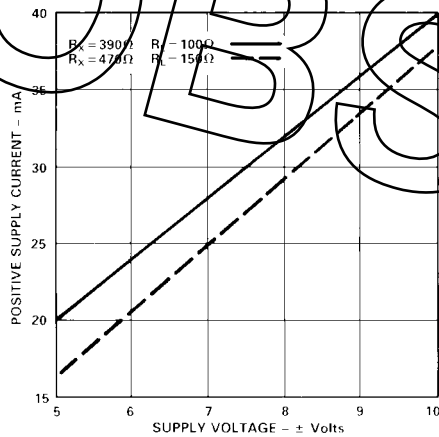

Figure 4. Positive Supply Current vs. Supply Voltage

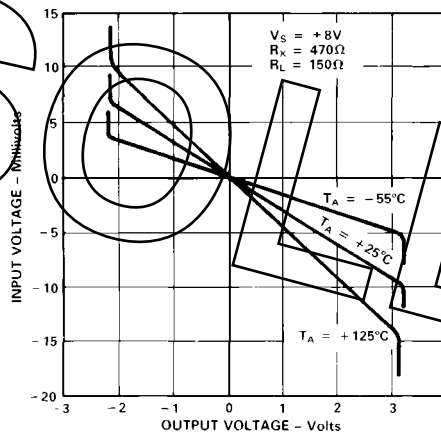

Figure 5. Input Voltage vs. Output Voltage for Various Temperatures

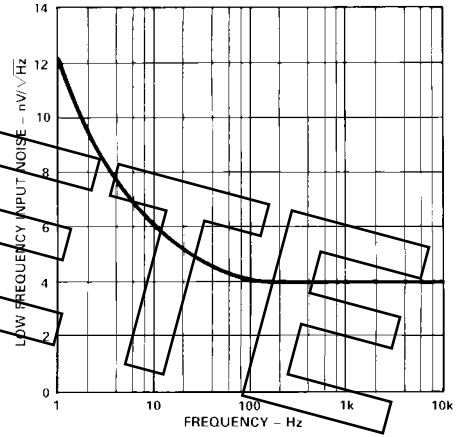

Figure 6. Low Frequency Input Noise vs. Frequency

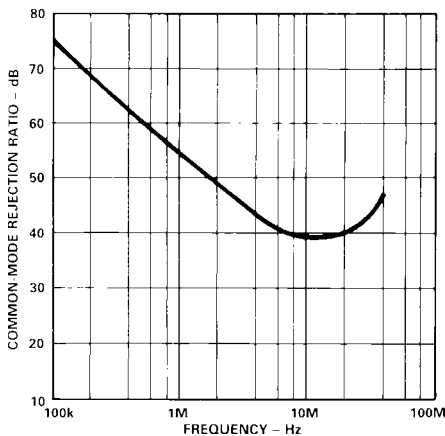

Figure 7. Common-Mode Rejection Ratio vs. Frequency

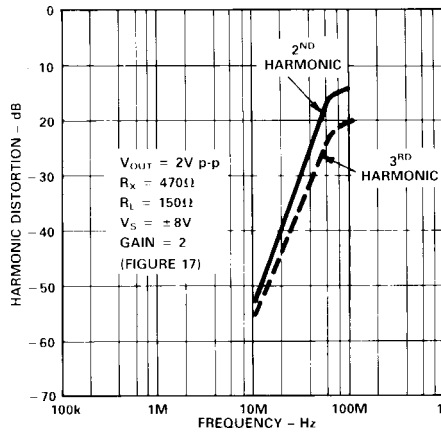

Figure 8. Harmonic Distortion vs. Frequency – Low Gain

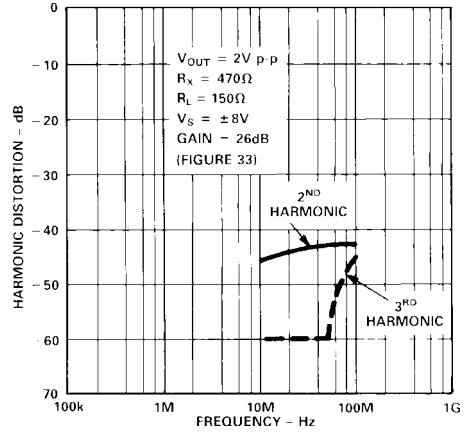

Figure 9. Harmonic Distortion vs. Frequency – High Gain

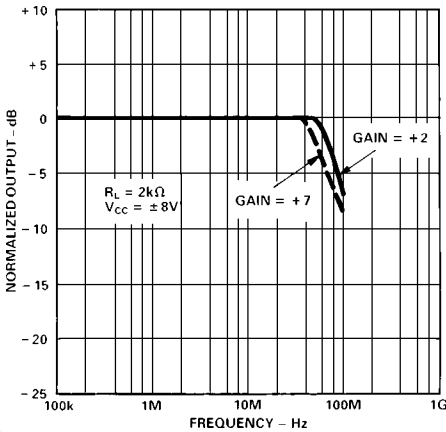

Figure 10. Full Power Response

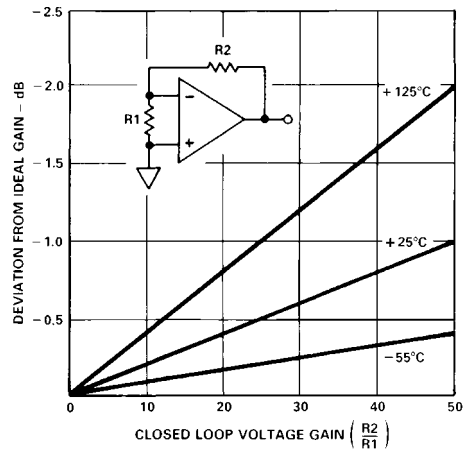

Figure 11. Deviation from Ideal Gain vs. Closed-Loop Voltage Gain

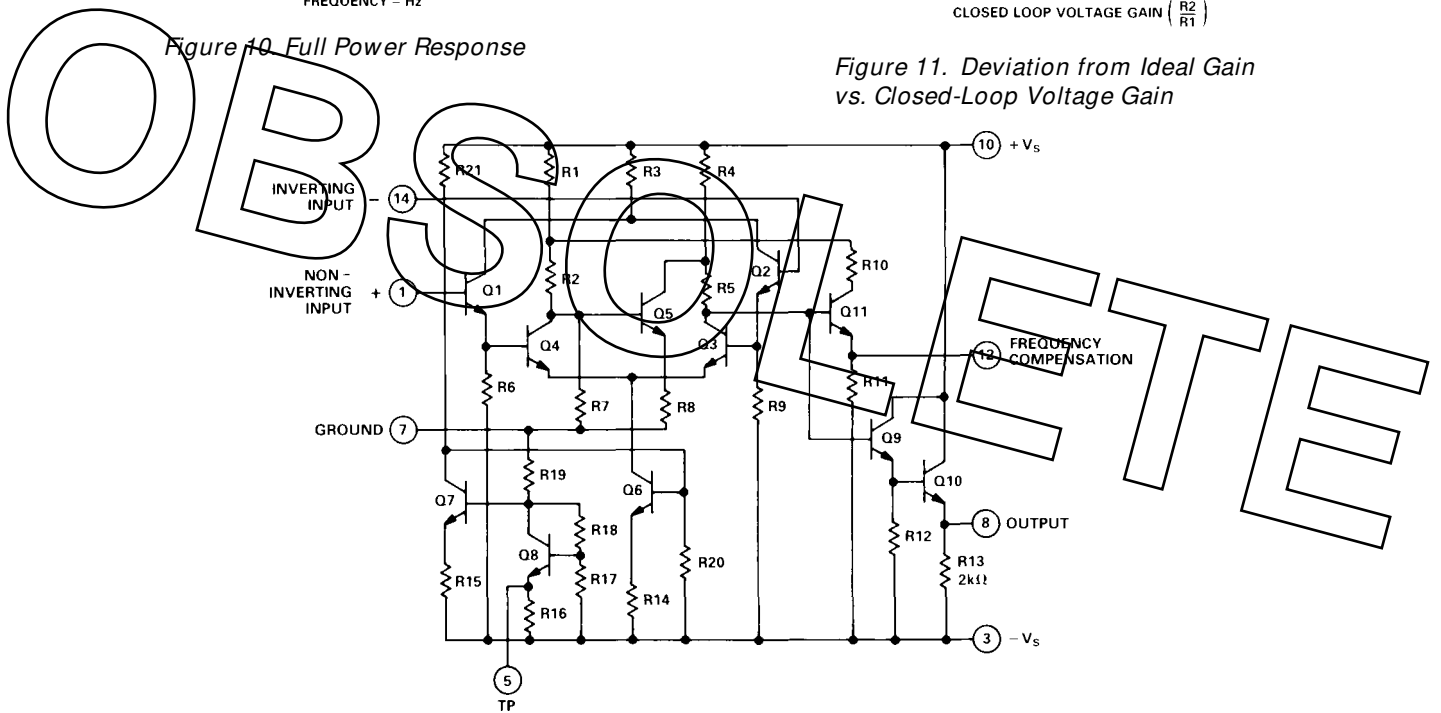

Figure 12. AD5539 Circuit

**FUNCTIONAL DESCRIPTION**

The AD5539 is a two-stage, very high frequency amplifier. Darlington input transistors Q1, Q4-Q2, Q3 form the first stage—a differential gain amplifier with a voltage gain of approximately 50. The second stage, Q5, is a single-ended amplifier whose input is derived from one phase of the differential amplifier output; the other phase of the differential output is then summed with the output of Q5. The all NPN design of the AD5539 is configured such that the emitter of Q5 is returned, via a small resistor to ground; this eliminates the need for separate level shifting circuitry.

The output stage, consisting of transistors Q9 and Q10, is a Darlington voltage follower with a resistive pull-down. The bias section, consisting of transistors Q6, Q7 and Q8, provides a stable emitter current for the input section, compensating for temperature and power supply variations.

**SOME GENERAL PRINCIPLES OF HIGH FREQUENCY CIRCUIT DESIGN**

In designing practical circuits with the AD5539, the user must remember that whenever very high frequencies are involved,

some special precautions are in order. All real-world applications circuits must be built using proper RF techniques: the use of short interconnect leads, adequate shielding, groundplanes, and very low profile IC sockets. In addition, very careful bypassing of power supply leads is a must.

Low-impedance transmission line is frequently used to carry signals at RF frequencies: 50 Ω line for telecommunications purposes and 75 Ω for video applications. The AD5539 offers a relatively low output impedance; therefore, some consideration must be given to impedance matching. A common matching technique involves simply placing a resistor in series with the amplifier output that is equal to the characteristic impedance of the transmission line. This provides a good match (although at a loss of 6 dB), adequate for many applications.

All of the circuits here were built and tested in a 50 Ω system. Care should be taken in adapting these circuits for each particular use. Any system which has been properly matched and terminated in its characteristic impedance should have the same small signal frequency response as those shown in this data sheet.

**APPLYING THE AD5539**

The AD5539 is stable for closed-loop gains of 4 or more as an inverter and at (noise) gains of 5 or greater as a voltage follower. This means that whenever the AD5539 is operated at noise gains below 5, external frequency compensation must be used to insure stable operation.

The following sections outline specific compensation circuits which permit stable operation of the AD5539 down to follower (noise) gains of 3 (inverting gains of 2) with corresponding -3 dB bandwidths up to 390 MHz. External compensation is achieved by modifying the frequency response to the AD5539's external feedback network (i.e., by adding lead-lag compensation) so that the amplifier operates at a noise gain of 5 (or more) at frequencies over 44 MHz, independent of signal gain.

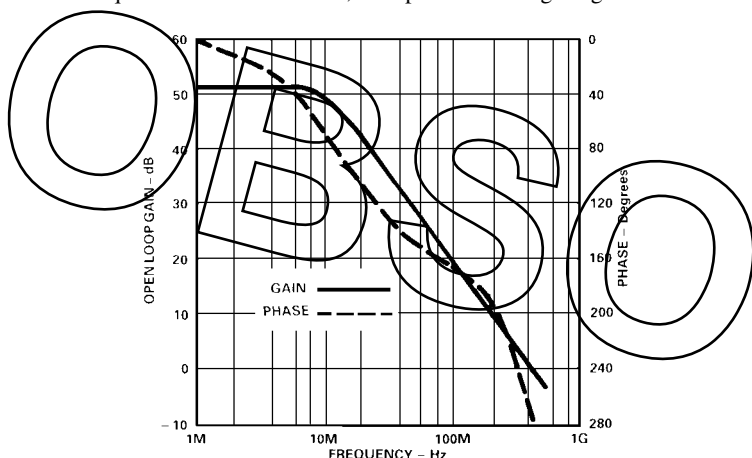

Figure 13. Small Signal Open-Loop Gain and Phase vs. Frequency

**GENERAL PRINCIPLES OF LEAD AND LAG COMPENSATION**

The AD5539 has its first pole or breakpoint in its open-loop frequency response at about 10 MHz (see Figure 13). At frequencies beyond 100 MHz, phase shift increases such that the output lags the input by 180°—well before the unity gain crossover frequency. Therefore, severe peaking (and possible oscillation) will result if the AD5539 is operated at noise gains below 5, unless external compensation is employed. Figure 14 shows the uncompensated closed-loop frequency response of the AD5539

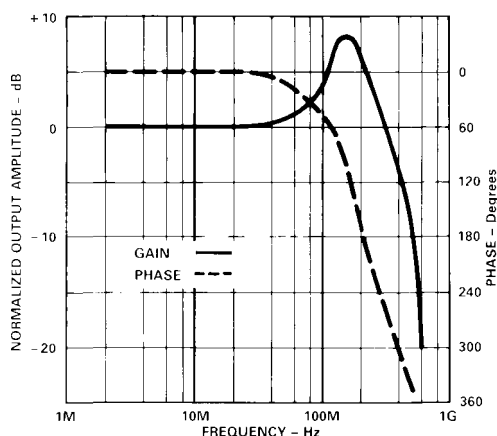

Figure 14. AD5539 Uncompensated Response, Closed-Loop Gain = 7

when operating at a noise gain of 7. Under these conditions, excess phase shift causes nearly 10 dB of peaking at 150 MHz.

Figure 15 illustrates the use of both lead and lag compensation to permit stable low-gain operation. The AD5539 is shown connected as an inverting amplifier with the required external components added to provide stability and improve high frequency response. The stray capacitance between the amplifier summing junction and ground,  $C_X$ , represents whatever capacitance is associated with the particular type of op amp package used plus the stray wiring capacitance at the summing junction.

Evaluating the lead capacitance first (ignoring  $R_{LAG}$  and  $C_{LAG}$  for now): the feedback network, consisting of  $R_2$  and  $C_{LEAD}$ , has a pole frequency equal to:

$$F_A = \frac{1}{2\pi(C_{LEAD} + C_X)(R_1 || R_2)} \quad (1)$$

and a zero frequency equal to:

$$F_B = \frac{1}{2\pi(R_1 \times C_{LEAD})} \quad (2)$$

Usually, frequency  $F_A$  is made equal to  $F_B$ ; that is,  $(R_1 C_X) = (R_2 C_{LEAD})$ , in a manner similar to the compensation used for an attenuator or scope probe. However, if the pole frequency,  $F_A$  will lie above the unity gain crossover frequency (440 MHz), then the optimum location of  $F_B$  will be near the crossover

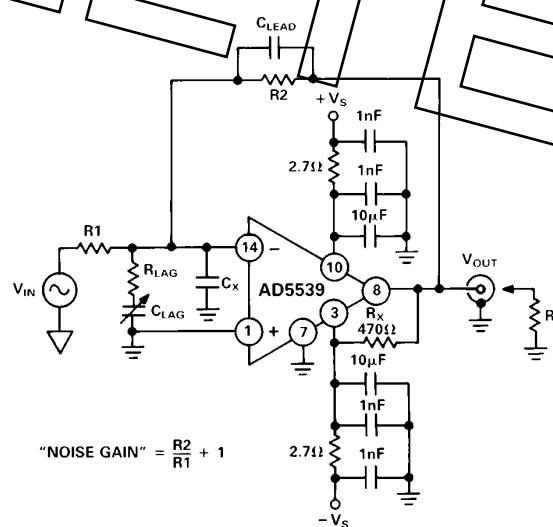

Figure 15. Inverting Amplifier Model Showing Both Lead and Lag Compensation

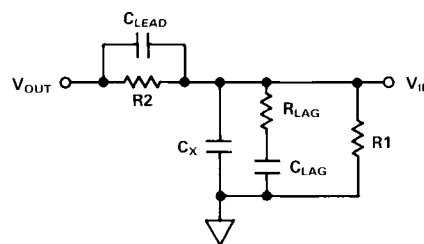

Figure 16. A Model of the Feedback Network of the Inverting Amplifier

# AD5539

frequency. Both of these circuit techniques add a large amount of leading phase shift at the crossover frequency, greatly aiding stability.

The lag network ( $R_{LAG}$ ,  $C_{LAG}$ ) increases the feedback attenuation, i.e., the amplifier operates at a higher noise gain, above some frequency, typically one-tenth of the crossover frequency. As an example, to achieve a noise gain of 5 at frequencies above 44 MHz, for the circuit of Figure 15, would require a network of:

$$R_{LAG} = \frac{R1}{(4R1/R2) - 1} \quad (3)$$

and . . .

$$C_{LAG} = \frac{1}{2\pi R_{LAG} (44 \times 10^6)} \quad (4)$$

It is worth noting that an  $R_{LAG}$  resistor may be used alone, to increase the noise gain above 5 at all frequencies. However, this approach has the disadvantage of also increasing the dc offset and low frequency noise errors by an amount equal to the increase in gain, in this case, by a factor of 5.

## SOME PRACTICAL CIRCUITS

The preceding general principles may now be applied to some actual circuits.

### A General Purpose Inverter Circuit

Figure 17 is a general purpose inverter circuit operating at a gain of -2.

For this circuit, the total capacitance at the inverting input is approximately 3 pF; therefore,  $C_{LEAD}$  from Equations 1 and 2 needs to be approximately 1.5 pF. As shown in Figure 17, a small trimmer is used to optimize the frequency response of this circuit. Without a lag compensation network, the noise gain of the circuit is 3.0 and, as shown in Figure 18, the output amplitude remains within  $\pm 0.5$  dB to 170 MHz and the -3 dB bandwidth is 200 MHz.

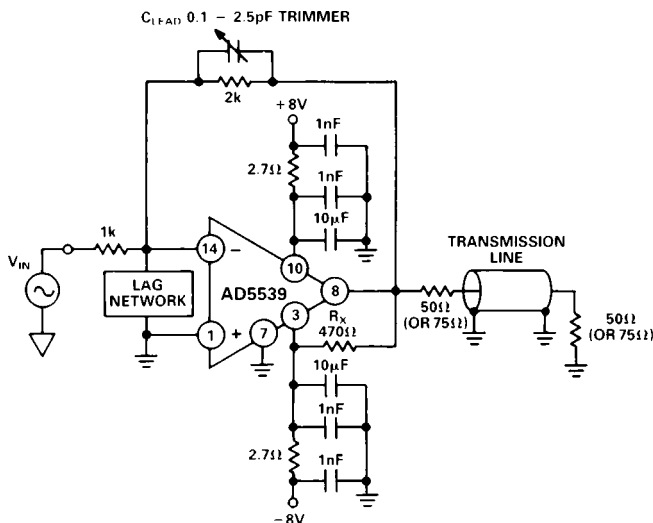

Figure 17. A General Purpose Inverter Circuit

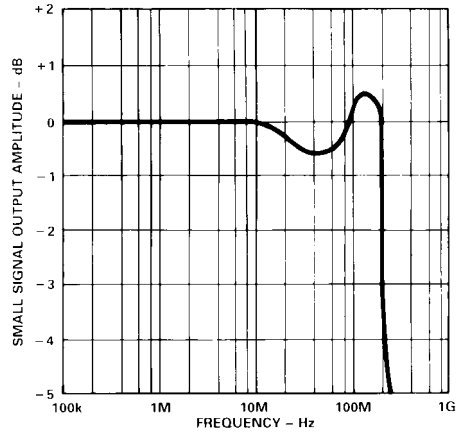

Figure 18. Response of the (Figure 17) Inverter Circuit without a Lag Compensation Network

A lag network (Figure 15) can be added to improve the response of this circuit even further as shown in Figures 19 and 20. In almost all cases, it is imperative to make capacitor  $C_{LEAD}$  adjustable; in some cases,  $C_{LAG}$  must also be variable. Otherwise, component and circuit capacitance variations will dominate circuit performance.

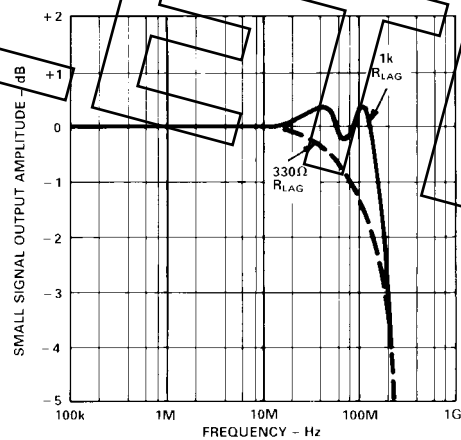

Figure 19. Response of the (Figure 17) Inverter Circuit with an  $R_{LAG}$  Compensation Network Employed

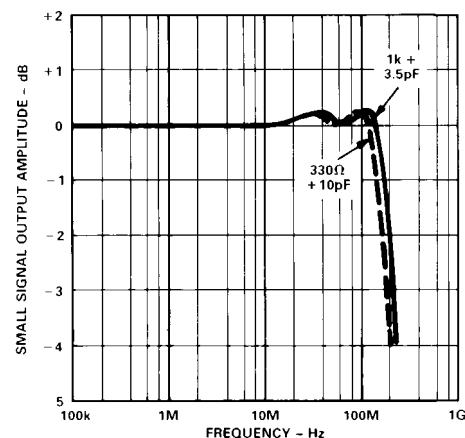

Figure 20. Response of the (Figure 17) Inverter Circuit with an  $R_{LAG}$  and a  $C_{LAG}$  Compensation Network Employed



Figures 21 and 22 show the small and large signal pulse responses of the general purpose inverter circuit of Figure 17, with  $C_{LEAD} = 1.5 \text{ pF}$ ,  $R_{LAG} = 330 \Omega$  and  $C_{LAG} = 3.5 \text{ pF}$ .

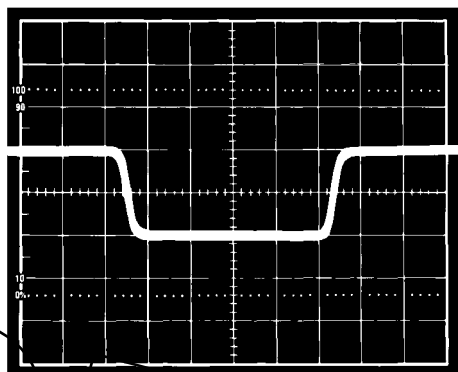

Figure 21. Small Signal Pulse Response of the (Figure 17) Inverter Circuit; Vertical Scale: 50 mV/div; Horizontal Scale: 5 ns/div

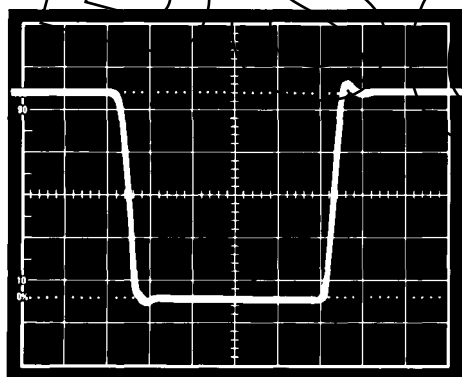

Figure 22. Large Signal Response of the (Figure 17) Inverter Circuit; Vertical Scale: 200 mV/div, Horizontal Scale: 5 ns/div

A  $C_{LEAD}$  capacitor may be used to limit the circuit bandwidth and to achieve a single pole response free of overshoot

$$\left( -3 \text{ dB frequency} = \frac{1}{2 \pi R_2 C_{LEAD}} \right)$$

If this option is selected, it is recommended that a  $C_{LEAD}$  be connected between Pin 12 and the summing junction, as shown in Figure 23. Pin 12 provides a separately buffered version of the output signal. Connecting the lead capacitor here avoids the excess output-stage phase shift and subsequent oscillation problems (at approx. 350 MHz) which would otherwise occur when using the circuit of Figure 17 with a  $C_{LEAD}$  of more than about 2 pF.

Figure 24 shows the response of the circuit of Figure 23 for each connection of  $C_{LEAD}$ . Lag components may also be added to this circuit to further tailor its response, but, in this case, the results will be slightly less satisfactory than connecting  $C_{LEAD}$  directly to the output, as was done in Figure 17.

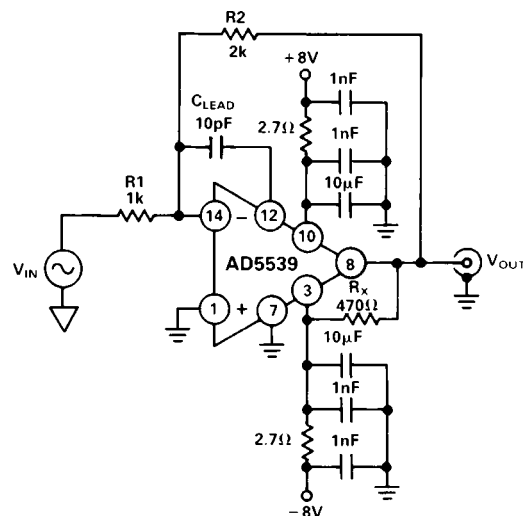

Figure 23. A Gain of 2 Inverter Circuit with the  $C_{LEAD}$  Capacitor Connected to Pin 12

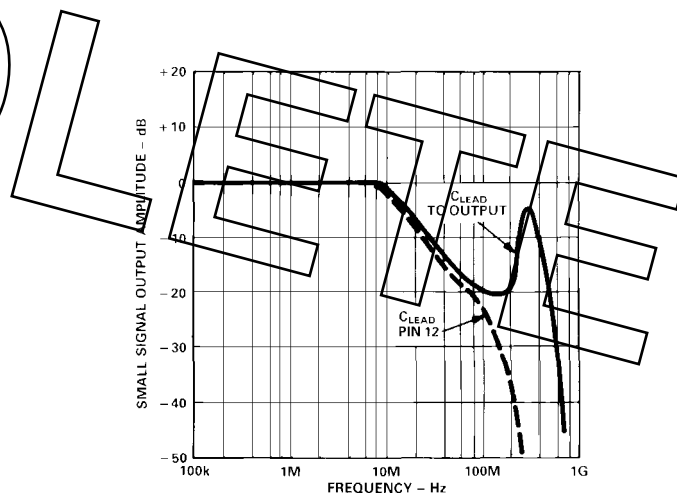

Figure 24. Response of the Circuit of Figure 23 with  $C_{LEAD} = 10 \text{ pF}$

### A General Purpose Voltage Follower Circuit

Noninverting (voltage follower) circuits pose an additional complication, in that when a lag network is used, the source impedance will affect the noise gain. In addition, the slightly greater bandwidth of the noninverting configuration makes any excess phase shift due to the output stage more of a problem.

For example, a gain of 3 noninverting circuit with  $C_{LEAD}$  connected normally (across the feedback resistor – Figure 25) will require a source resistance of 200  $\Omega$  or greater to prevent UHF oscillation; the extra source resistance provides some damping as well as increasing the noise gain. The frequency response plot of Figure 26 shows that the highest  $-3 \text{ dB}$  frequency of all the applications circuits can be achieved using this connection, unfortunately, at the expense of a noise gain of 14.2.

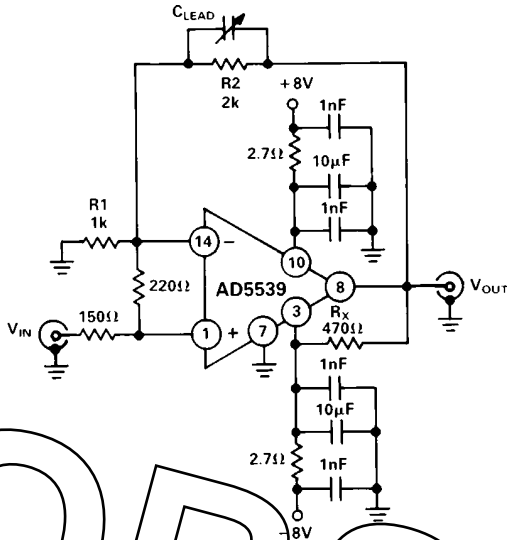

Figure 25. A Gain of 3 Follower with Both Lead and Lag Compensation

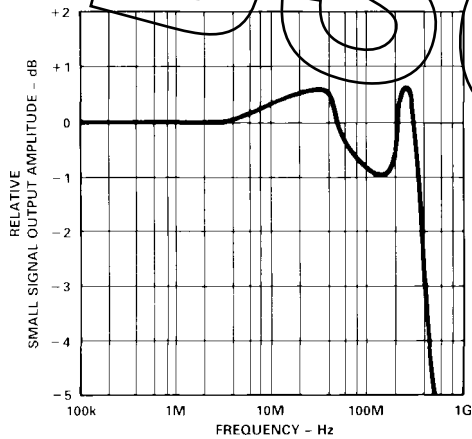

Figure 26. Response of the Gain of 3 Follower Circuit

Adding a lag capacitor (Figure 27) will greatly reduce the midband and low frequency noise gain of the circuit while sacrificing only a small amount of bandwidth as shown in Figure 28.

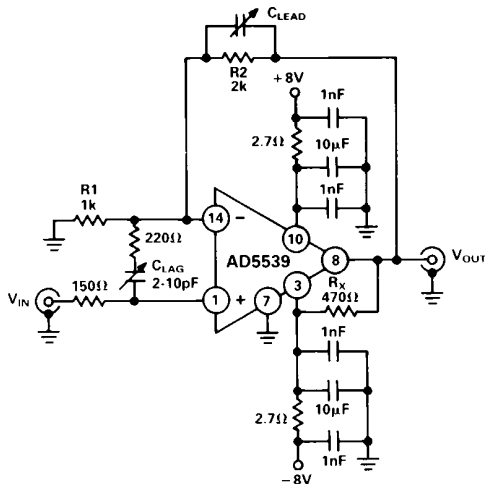

Figure 27. A Gain of 3 Follower Circuit with Both  $C_{LEAD}$  and  $R_{LAG}$  Compensation

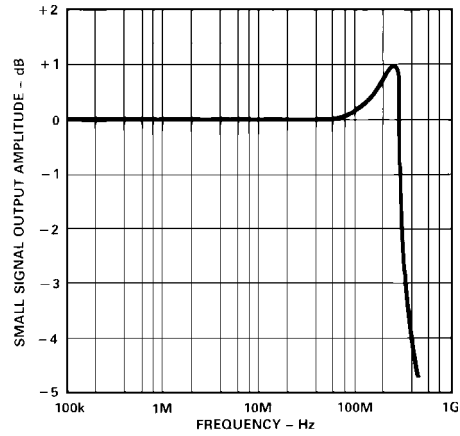

Figure 28. Response of the Gain of 3 Follower with  $C_{LEAD}$ ,  $C_{LAG}$  and  $R_{LAG}$

These same principles may be applied when capacitor  $C_{LEAD}$  is connected to Pin 12 (Figure 29). Figure 30 shows the bandwidth of the gain of 3 amplifier for various values of  $R_{LAG}$ . It can be seen from these response plots that a high noise gain is still needed to achieve a reasonably flat response (the smaller the

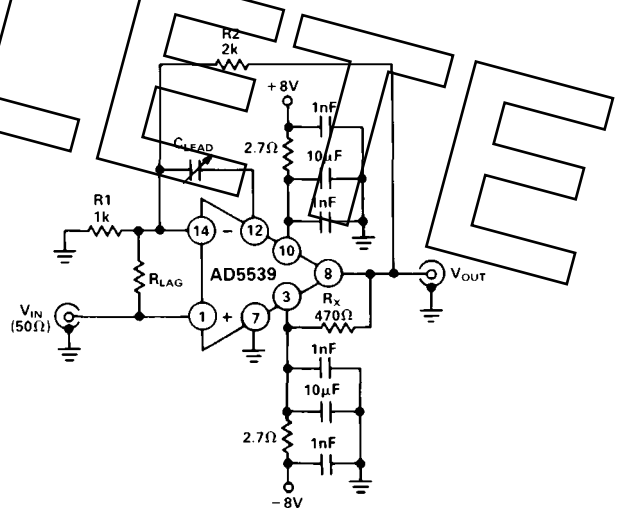

Figure 29. A Gain of 3 Follower Circuit with  $C_{LEAD}$  Compensation Connected to Pin 12

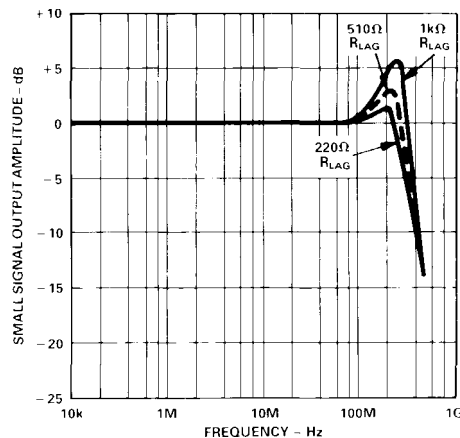

Figure 30. Response of the Gain of 3 Follower Circuit with  $C_{LEAD}$  Connected to Pin 12

value of  $R_{LAG}$ , the higher the noise gain). For example, with a  $220\ \Omega$   $R_{LAG}$  and a  $50\ \Omega$  source resistance, the noise gain will be 12.8, because the source resistance affects the noise gain.

Figures 31 and 32 show the small and large signal responses of the circuit of Figure 29.

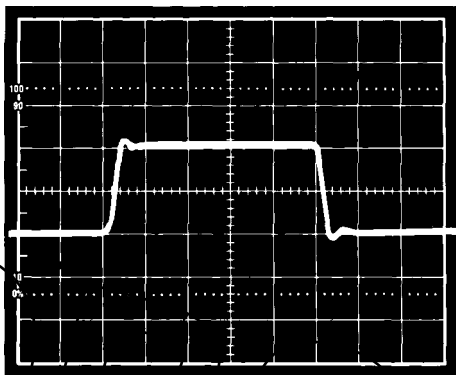

Figure 31. The Small-Signal Pulse Response of the Gain of 3 Follower Circuit with  $R_{LAG}$  and  $C_{LEAD}$  Compensation to Pin 12; Vertical Scale: 50 mV/div; Horizontal Scale: 5 ns/div

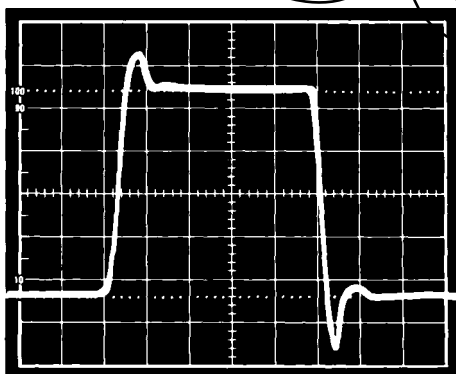

Figure 32. The Large-Signal Pulse Response of the Gain of 3 Follower Circuit with  $R_{LAG}$  and  $C_{LEAD}$  Compensation to Pin 12; Vertical Scale: 200 mV/div; Horizontal Scale: 5 ns/div

#### A Video Amplifier Circuit with 20 dB Gain (Terminated)

High gain applications (14 dB and up) require only a small lead capacitance to obtain flat response. The 26 dB (20 dB terminated) video amplifier circuit of Figure 33 has the response shown in Figure 34 using only approximately 0.5-1 pF lead capacitance. Again, a small  $C_{LEAD}$  can be connected, either to the output or to Pin 12 with very little difference in response.

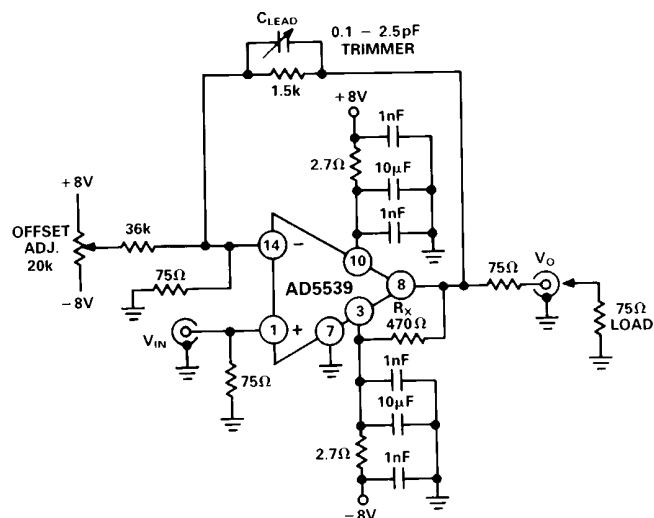

Figure 33. A 20 dB Gain Video Amplifier for 75  $\Omega$  Systems

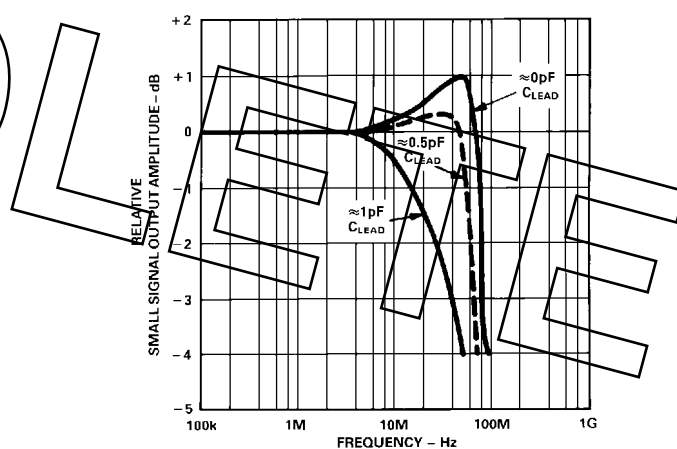

Figure 34. Response of the 20 dB Video Amplifier

In color video applications, the quality of differential gain and differential phase response is very important. Figures 35 and 36 show a circuit and test setup to measure the AD5539's response to a modulated ramp signal (0-90 IRE p-p ramp, 40 IRE p-p modulation, 4.4 MHz).

Figures 37 and 38 show the differential gain and phase response.

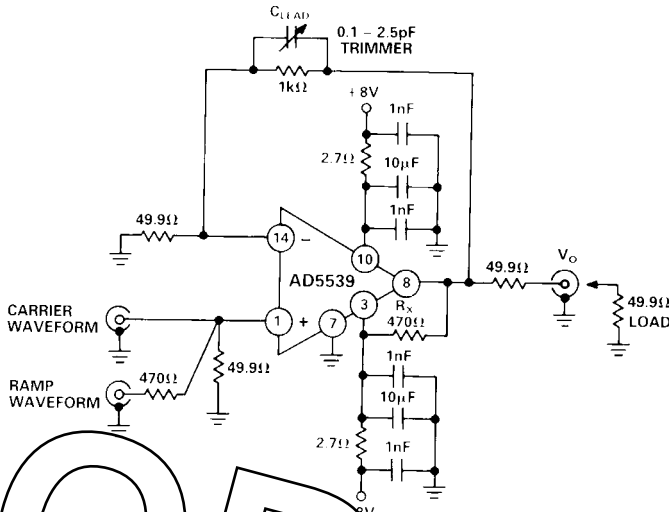

Figure 35. Differential Gain and Phase Measurement Circuit

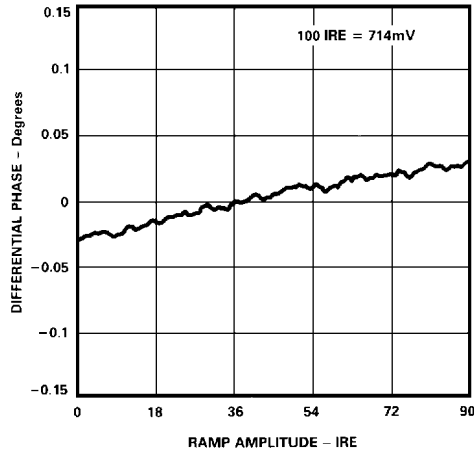

Figure 38. Differential Phase vs. Ramp Amplitude

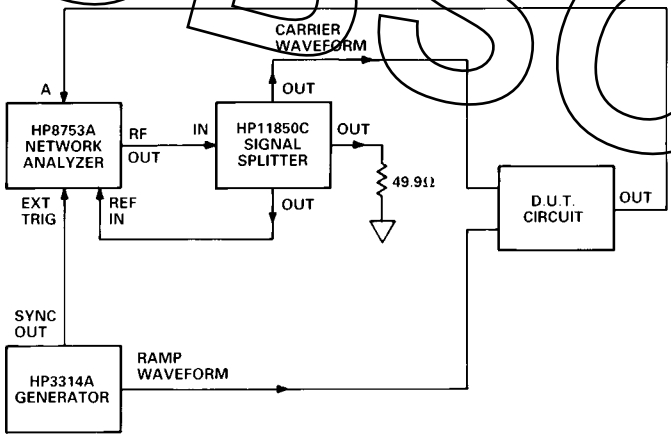

Figure 36. Differential Gain and Phase Test Setup

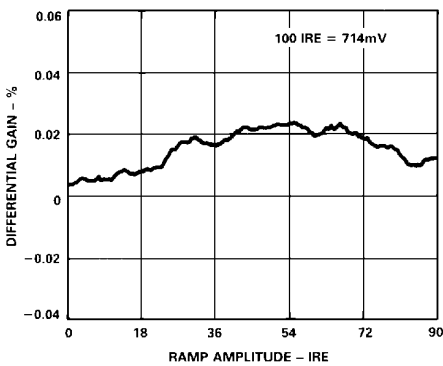

Figure 37. Differential Gain vs. Ramp Amplitude

**MEASURING AD5539 SETTLING TIME**

Measuring the very rapid settling times associated with AD5539 can be a real problem for the designer; proper component layout must be used and appropriate test equipment selected. In addition, both cable dispersion (a function of cable losses) and the quality of termination (SWR) directly affect the measurement. The circuit of Figure 39 was used to make a "brute force" AD5539 settling time measurement. The fixture containing the circuit was connected directly—using a male BNC connector (but no cable)—onto the front of a 50 Ω input oscilloscope preamp. A digital mainframe was then used to capture, average, and expand the error signal. Most of the small-scale waveform aberrations shown on the figure were caused by the oscilloscope itself, especially the glitch at 15 ns. The pulse source used for this measurement was an EH-SPG2000 pulse generator set for a 1 ns rise-time; it was coupled directly to the circuit using 18" of microwave 50 Ω hard line.

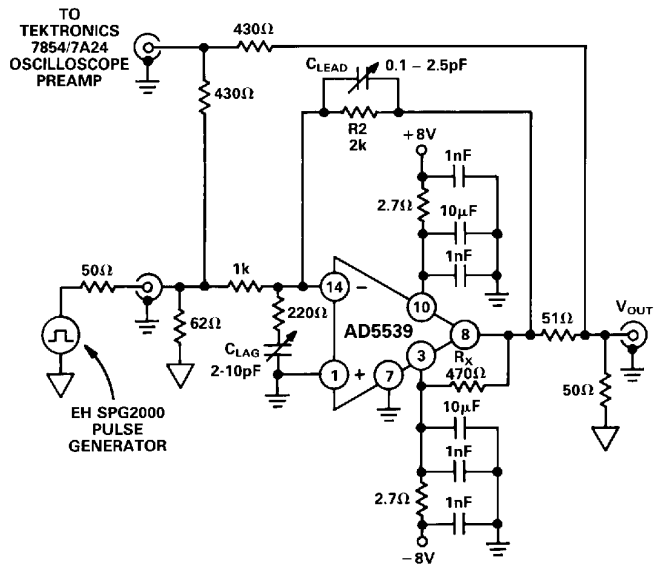

Figure 39. AD5539 Settling Time Test Circuit

## APPLICATIONS SUMMARY CHART

	R1	R2 <sup>1</sup>	R <sub>LAG</sub>	C <sub>LAG</sub> <sup>2</sup>	C <sub>LEAD</sub> <sup>2</sup>	GAIN	GAIN FLATNESS (TRIMMED)	3 dB BANDWIDTH
Gain = -1 to -5 Circuit of Fig. 17	$\frac{R2}{G}$	2 k	$\leq \frac{R1}{4 \frac{R1}{R2} - 1}$	$\geq \frac{1}{2 \pi (44 \times 10^6) R_{LAG}}$	$\approx \frac{3 pF}{G}$	-2	±0.2 dB	200 MHz
Gain = -1 to -5 Circuit of Fig. 23	$\frac{R2}{G}$	2 k	$\leq \frac{R1}{4 \frac{R1}{R2} - 1}$	$\geq \frac{1}{2 \pi (44 \times 10^6) R_{LAG}}$	$\approx \frac{3 pF}{G}$	-2	±1 dB	180 MHz
Gain = +2 to +5 <sup>3</sup> Circuit of Fig. 27	$\frac{R2}{G-1}$	2 k	$\leq \frac{R1}{10 \frac{R1}{R2} - 1}$	$\geq \frac{1}{2 \pi (44 \times 10^6) R_{LAG}}$	$\approx \frac{3 pF}{G-1}$	+3	±1 dB	390 MHz
Gain = +2 to +5 <sup>4</sup> Circuit of Fig. 29	$\frac{R2}{G-1}$	2 k	$\leq \frac{R1}{10 \frac{R1}{R2} - 1}$	NA	$\approx \frac{3 pF}{G-1}$	+3	±0.5 dB	340 MHz
Gain < -5	$\frac{R2}{G}$	1.5 k	NA	NA	Trimmer <sup>5</sup>	-20	±0.2 dB	80 MHz
Gain > +5	$\frac{R2}{G-1}$	1.5 k	NA	NA	Trimmer <sup>5</sup>	+20	±0.2 dB	80 MHz

## NOTES

G = Gain NA = Not Applicable

<sup>1</sup>Values given for specific results summarized here—applications can be adapted for values different than those specified.<sup>2</sup>It is recommended that C<sub>LEAD</sub> and C<sub>LAG</sub> be trimmers covering a range that includes the computed value above.<sup>3</sup>R<sub>SOURCE</sub> ≥ 200 Ω.<sup>4</sup>R<sub>SOURCE</sub> ≥ 50 Ω.<sup>5</sup>Use Voltronics CPA2 0.1–2.5 pF Teflon Trimmer Capacitor (or equivalent).

The photos of Figures 40 and 41 demonstrate how the AD5539 easily settles to 1% (1 mV) in less than 12 ns; settling to 0.1% (100 μV) requires less than 25 ns.

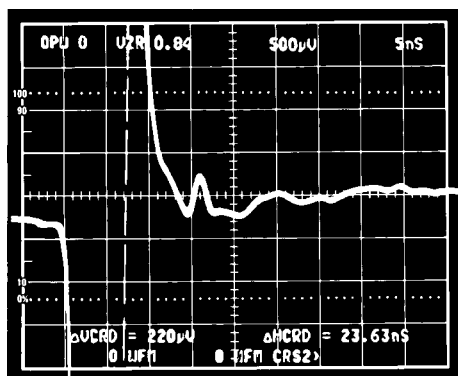

Figure 40. Error Signal from AD5539 Settling Time Test Circuit – Falling Edge. Vertical Scale: 5 ns/div.; Horizontal Scale: 500 μV/div

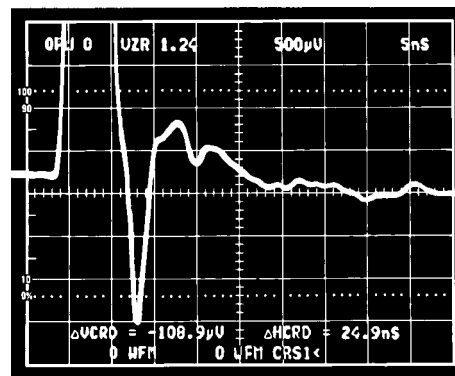

Figure 41. Error Signal from AD5539 Settling Time Test Circuit – Rising Edge. Vertical Scale: 5 ns/div.; Horizontal Scale: 500 μV/div

# AD5539

Figure 42 shows the oscilloscope response of the generator alone, set up to simulate the ideal test circuit error signal (Figure 43).

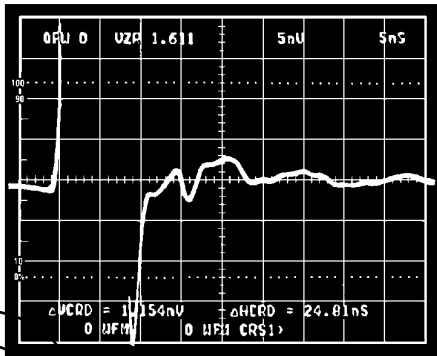

Figure 42. The Oscilloscope Response Alone Directly Driven by the Test Generator. Vertical Scale: 5 ns/div.; Horizontal Scale: 500 μV/div

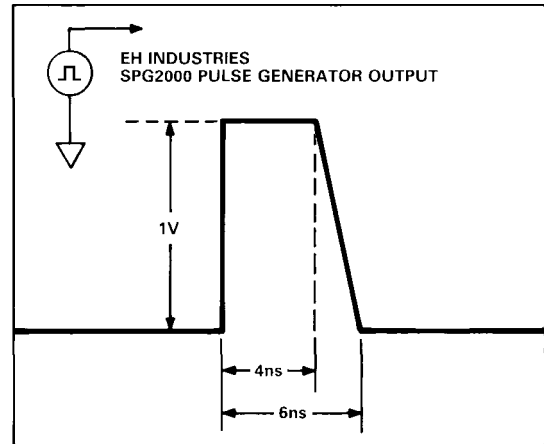
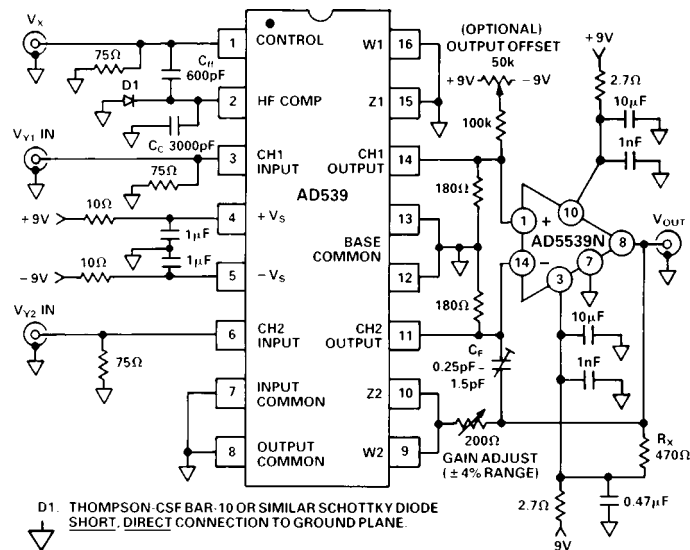

Figure 43. A Simulated Ideal Test Circuit Error Signal

## A 50 MHz VOLTAGE-CONTROLLED AMPLIFIER

Figure 44 is a circuit for a 50 MHz voltage-controlled amplifier (VCA) suitable for use in high quality video-speed applications. This circuit uses the AD5539 as an output amplifier for the AD539, a high bandwidth multiplier. The outputs from the two signal channels of the AD539 are applied to the op amp in a subtracting configuration. This connection has two main advantages: first, it results in better rejection of the control voltage, particularly when over-driven ( $V_X < 0$  or  $V_X > 3.3$  V). Secondly, it provides a choice of either noninverting or inverting responses, using either input  $V_{Y1}$  or  $V_{Y2}$ , respectively. In this circuit, the output of the op amp will equal:

$$V_{OUT} = \frac{V_X (V_{Y1} - V_{Y2})}{2V} \text{ for } V_X > 0$$



D1. THOMPSON-CSF BAR-10 OR SIMILAR SCHOTTKY DIODE  
SHORT, DIRECT CONNECTION TO GROUND PLANE.

Figure 44. A Wide Bandwidth Voltage-Controlled Amplifier

Hence, the gain is unity at  $V_X = +2$  V. Since  $V_X$  can overrange to +3.3 V, the maximum gain in this configuration is about 4.3 dB. (Note: If Pin 9 of the AD5539 is grounded, rather than connected to the output of the 5539N, the maximum gain becomes 0 dB.)

The bandwidth of this circuit is over 50 MHz at full gain, and is not substantially affected at lower gains. Of course, when  $V_X$  is zero (or slightly negative, to override the residual input offset) there is still a small amount of capacitive feedthrough at high frequencies; therefore, extreme care is needed in laying out the PC board to minimize this effect. Also, for small values of  $V_X$  the combination of this feedthrough with the multiplier output can cause a dip in the response where they are out of phase. Figure 45 shows the ac response from the noninverting input, with the response from the inverting input,  $V_{Y2}$ , essentially identical. Test conditions:  $V_{Y1} = 0.5$  V rms for values of  $V_X$  from +10 mV to +3.16 V; this is with a 75 Ω load on the output. The feedthrough at  $V_X = -10$  mV is also shown.

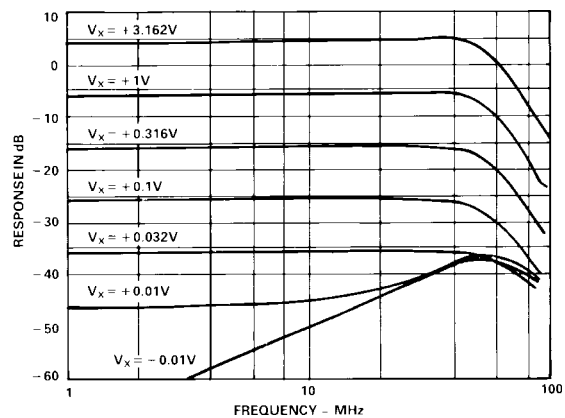

Figure 45. AC Response of the VCA at Different Gains  $V_Y = 0.5$  V RMS

The transient response of the signal channel at  $V_X = +2$  V,  $V_Y = V_{OUT} = +$  or  $-1$  V is shown in Figure 46; with the VCA driving a  $75\ \Omega$  load. The rise and fall times are both approximately 7 ns.

A few final circuit details: in general, the control amplifier compensation capacitor for Pin 2,  $C_C$ , must have a minimum value of 3000 pF (3 nF) to provide both circuit stability and maximum control bandwidth. However, if the *maximum* control bandwidth is not needed, then it is advisable to use a larger value of  $C_C$ , with typical values between 0.01 and 0.1  $\mu$ F. Like many aspects of design, the value of  $C_C$  will be a tradeoff: higher values of  $C_C$  will lower the high frequency distortion, reduce the high frequency crosstalk and improve the signal channel phase response. Conversely, lower values of  $C_C$  will provide a higher control channel bandwidth at the expense of degraded linearity in the output response when amplitude modulating a carrier signal.

The control channel bandwidth will vary in inverse proportion to the value of  $C_C$ , providing a typical bandwidth of 2 MHz with a  $C_C$  of 0.01  $\mu$ F and a  $V_X$  voltage of +1.7 volts.

Both the bandwidth and pulse response of the control channel can be further increased by using a feedforward capacitor,  $C_{ff}$ , with a value between 5 and 20 percent of  $C_C$ .  $C_{ff}$  should be carefully adjusted to give the best pulse response for a particular step input applied to the control channel. Note that since  $C_{ff}$  is connected between a linear control input (Pin 1) and a logarithmic

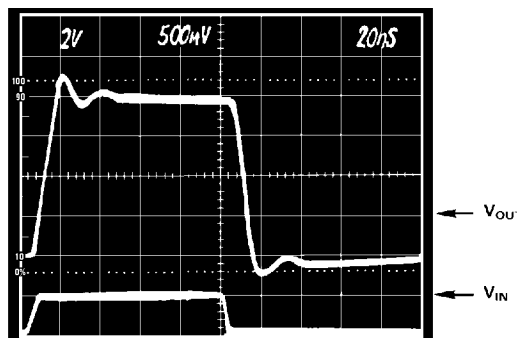

Figure 46. Transient Response of the Voltage-Controlled Amplifier  $V_X = +2$  Volts,  $V_Y = \pm 1$  Volt

mic node, the settling time of the control channel with a pulse input will vary with different control input step levels.

Diode D1 clamps the logarithmic control node at Pin 2 of the AD539, (preventing this point from going too negative); this diode helps decrease the circuit recovery time when the control input goes below ground potential.

**THE AD539/5539 COMBINATION AS A FAST, LOW FEEDTHROUGH, VIDEO SWITCH**

Figure 47 shows how the AD539/5539 combination can be used to create a fast video speed switch suitable for many high fre-

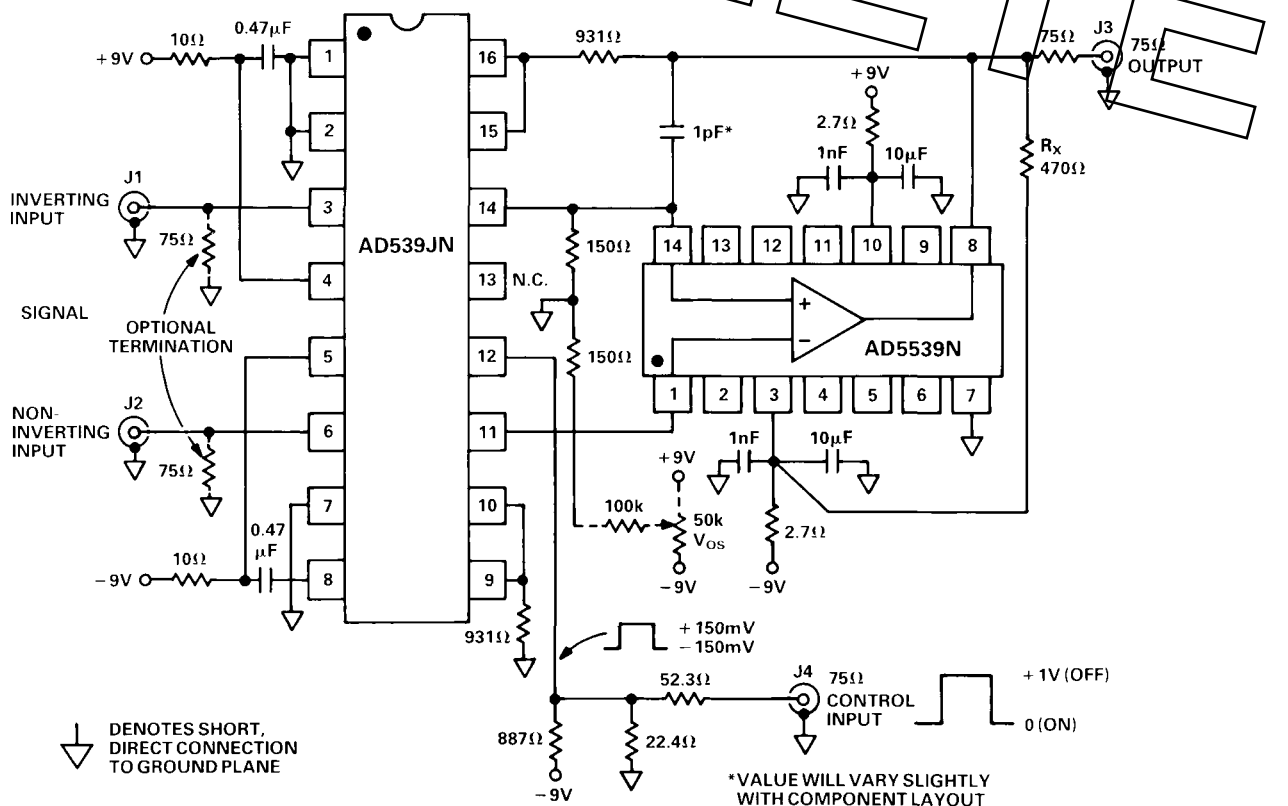

Figure 47. An Analog Multiplier Video Switch

# AD5539

quency applications including color key switching. It features both inverting and noninverting inputs and can provide an output of  $\pm 1$  V into a reverse-terminated  $75 \Omega$  load (or  $\pm 2$  V into  $150 \Omega$ ). An optional output offset adjustment is provided. The input range of the video switch is the same as the output range:  $\pm 1$  V at either input generates  $\pm 1$  V (noninverting) or  $\mp 1$  V (inverting) across the  $75 \Omega$  load. The circuit provides a gain of about 1, when "ON," or zero when "OFF."

The differential configuration uses both channels of the AD539 not only to provide alternative input phases, but also to eliminate the switching pedestal due to step changes in the output current as the AD539 is gated on or off.

Figure 49 shows the response to a pulse of 0 to +1 V on the signal channel. With the control input held at zero, the rise time is under 10 ns. The response from the inverting input is similar.

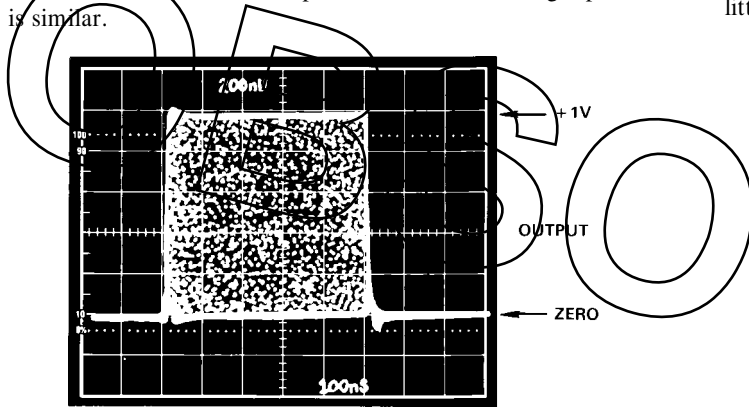

Figure 48. The Control Response of the Video Switcher

The differential-gain and differential-phase characteristics of this switch are compatible with video applications. The incremental gain changes less than 0.05 dB over a signal window of 0 to +1 V, with a phase variation of less than 0.5 degree at the subcarrier frequency of 3.58 MHz. The noise level of this circuit measured at the  $75 \Omega$  load is typically  $200 \mu\text{V}$  in a 0 MHz to 5 MHz bandwidth or approximately 100 nV per root hertz. The noise spectral density is essentially flat to 40 MHz.

The waveforms shown in Figures 48 and 49 were taken across a  $75 \Omega$  termination; in both photos, the signal of 0 to +1 V (in this case, an offset sine wave at 1 MHz) was applied to the noninverting input. In Figure 48, the envelope response shows the output being fully switched in about 50 ns. Note that the output is ON when the control input is zero (or more negative) and OFF for a control input of +1 V or more. There is very little control-signal breakthrough.

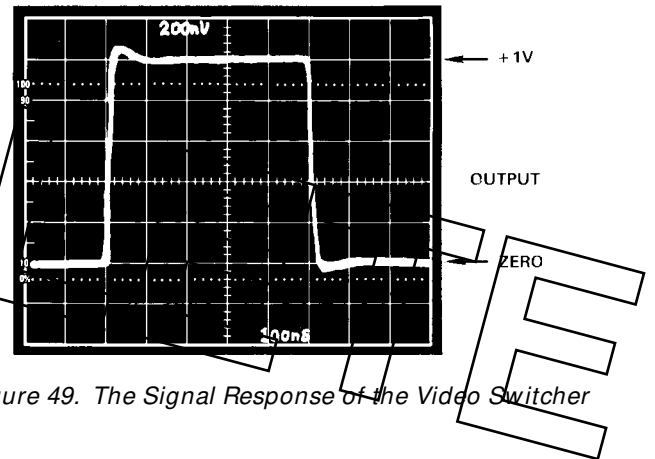
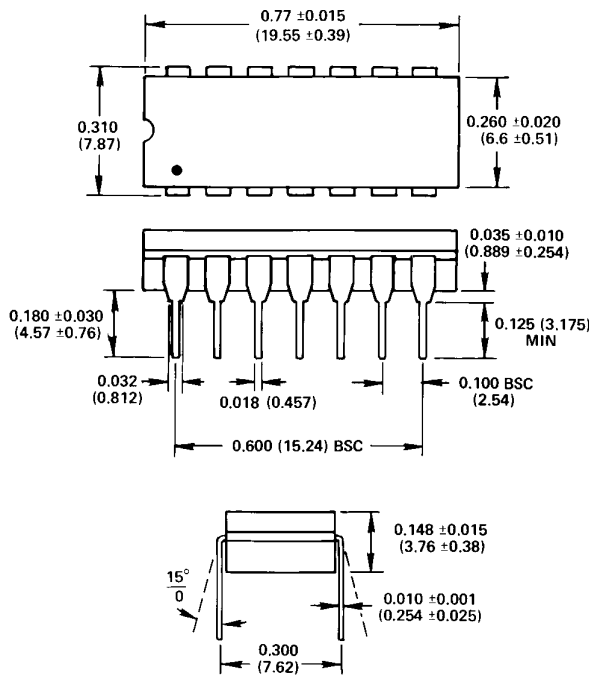

Figure 49. The Signal Response of the Video Switcher

## OUTLINE DIMENSIONS

Dimensions shown in inches and (mm).

### 14-Pin Cerdip Package (Q-14)



### 14-Pin Plastic DIP Package (N-14)

