



Embedded Storage

# **Ferri-eMMC<sup>®</sup>**

**Industrial eMMC 5.1 Memory Solution**

**SM662 BE Series**

**Datasheet**

(Simplified Edition)

**Revision 0.2**

**Mar 2021**

**Revision History**

Revision	Date	Description
0.1	Feb 6, 2020	Initial release.
0.2	Mar 5, 2021	<ul style="list-style-type: none"> <li>• Added automotive grade support (1.2) (4) (5)</li> <li>• Added 100-ball package (1.2), pin assignments (2.1), pin list (2.3), ordering information and top marking figure (5)</li> <li>• Updated the note, name or value for typical CSD register slices: [103:96], [61:59], [58:56], [55:53], [52:50] and [0:0] (3.3)</li> <li>• Updated the name, type, value and/or note for typical extended CSD register slices: [485:309], [269], [268], [267], [264], [261:254], [252:249], [241], [239], [238], [231], [230], [229], [226], [221], [203], [202], [201], [200], [195], [193], [192], [188], [186], [182], [180], [178], [175], [170], [163], [159:157], [21:18] and [14:0] (3.4)</li> <li>• Updated the symbol for operating temperature and storage temperature (4)</li> </ul>

SMI Confidential for Digi-Key Only

### Document Confidentiality Statement

The information contained in these documents is confidential, privileged and only for the information of the intended recipient and should not be disclosed to any other person. It may not be used, published or redistributed in whole, or in part, nor may any of the information contained therein be disclosed without the prior written consent of Silicon Motion, Inc. and its affiliates (collectively "SMI").

The recipient hereby agrees that reading of this datasheet is strictly limited to her/him as authorized by SMI. If any statement, notice, requirement and/or disclaimer set forth hereunder is unacceptable, the recipient shall return this document to SMI's contact window without any delay or it is deemed to be agreed and accepted by the recipient and her/his representing companies, incorporations, or any legal entity of these statements, notices, requirements and/or disclaimers.

### IMPORTANT NOTICE

INFORMATION IN THIS DOCUMENT IS PROVIDED IN CONNECTION WITH PRODUCTS OF SILICON MOTION, INC. ("SMI"). NO LICENSE, EXPRESS OR IMPLIED, BY ESTOPPEL OR OTHERWISE, TO ANY INTELLECTUAL PROPERTY RIGHTS IS GRANTED BY THIS DOCUMENT. EXCEPT AS PROVIDED IN SMI'S TERMS AND CONDITIONS OF SALE FOR SUCH PRODUCTS, SMI ASSUMES NO LIABILITY WHATSOEVER, AND SMI DISCLAIMS ANY EXPRESS OR IMPLIED WARRANTY, RELATING TO SALE AND/OR USE OF SMI PRODUCTS INCLUDING LIABILITY OR WARRANTIES FOR FITNESS FOR A PARTICULAR PURPOSE, MERCHANTABILITY, OR INFRINGEMENT OF ANY PATENT, COPYRIGHT OR OTHER INTELLECTUAL PROPERTY RIGHT.

SMI, its agents, and employees, and all persons acting on its or their behalf, disclaim any and all liability for any errors, inaccuracies or incompleteness contained in any datasheet or in any other disclosure relating to any product.

Statements regarding the suitability of products for certain types of applications are based on SMI's knowledge of typical requirements that are often placed on SMI's products in generic applications. Such statements are not binding statements about the suitability of products for a particular application. It is customer's responsibility to validate that a particular product with the properties described in the product specification and/or datasheet is suitable for use in a particular application.

SMI products are not intended for use in medical, life saving, life sustaining, critical control or safety systems, or in nuclear facility applications. SMI may make changes to specifications and product descriptions at any time, without notice. SMI may have patents or pending patent applications, trademarks, copyrights, or other intellectual property rights that relate to the presented subject matter. The furnishing of documents and other materials and information does not constitute any license, express or implied, by estoppel or otherwise, to any such patents, trademarks, copyrights, or other intellectual property rights. The information in this document is furnished for informational use only, is subject to change without notice, and should not be construed as a commitment by SMI. SMI assumes no responsibility or liability for any errors or inaccuracies that may appear in this document or any software that may be provided in association with this document. Except as permitted by such license, no part of this document may be reproduced, stored in a retrieval system, or transmitted in any form or by any means without the express written consent of SMI. Contact your local SMI sales office or your distributor to obtain the latest specifications and before placing your product order.

Silicon Motion and Silicon Motion logo are registered trademarks of SMI and/or its affiliates. Other brand names mentioned herein are for identification purposes only and may be trademarks and/or registered trademarks of their respective owners.

## Table of Contents

<b>1. Overview</b> .....	<b>7</b>
1.1 Product Description .....	7
1.2 Key Features .....	7
1.3 Block Diagram .....	9
<b>2. Pin Assignments and Signal Descriptions</b> .....	<b>10</b>
2.1 Pin Assignments .....	10
2.2 Signal Descriptions .....	12
2.3 Pin List .....	14
<b>3. Ferri-eMMC Registers</b> .....	<b>15</b>
3.1 CID Register .....	15
3.2 Relative Card Address Register (RCA) .....	15
3.3 CSD Register .....	16
3.4 Extended CSD Register (EXT_CSD) .....	18
<b>4. DC Electrical Characteristics</b> .....	<b>25</b>
<b>5. Ordering Information</b> .....	<b>27</b>
5.1 Product Coding Rule .....	27
5.2 Top Marking .....	28

SMI Confidential for  
Digi-Key  
Only

## List of Tables

Table 1:	Functional Signals .....	12
Table 2:	Miscellaneous Signals .....	13
Table 3:	Pin List of Ferri-eMMC Packages.....	14
Table 4:	Ferri-eMMC Typical CSD Register.....	16
Table 5:	Ferri-eMMC Typical EXT_CSD Register.....	18
Table 6:	Operating Conditions.....	25
Table 7:	Absolute Maximum Ratings.....	25
Table 8:	Product Code Definitions.....	27

SMI Confidential for  
Digi-Key  
Only

## List of Figures

Figure 1:	Ferri-eMMC Block Diagram.....	9
Figure 2:	100-Ball Pin Assignments (Top View - Balls Down).....	10
Figure 3:	153-Ball Pin Assignments (Top View - Balls Down).....	11
Figure 4:	Internal Power Diagram (Example).....	26
Figure 7:	SM662GX(E)B/C/D/E/F Top Marking (Example).....	28
Figure 8:	SM662PX(E)F Top Marking (Example).....	28
Figure 9:	SM662PX(E)B/C/D/E Top Marking (Example).....	29

SMI Confidential for  
Digi-Key  
Only

# 1. Overview

## 1.1 Product Description

---

Ferri-eMMC<sup>®</sup> is a highly integrated solution which combines a feature-wise flash controller and standard NAND flash memory. Its high performance and low power make the Ferri-eMMC a fabulous solution for embedded and portable applications.

The Ferri-eMMC leverages industry leading technology and experience in NAND management. In addition, the Ferri-eMMC supports the standard eMMC interface as well as the newly introduced eMMC features such as HS400 mode and FFU. By integrating all the advanced techniques, the Ferri-eMMC is able to further enhance the data transferring efficiency and optimizes the overall performance for embedded systems.

Available in various densities, the Ferri-eMMC offers the features, performance, and flexibility exactly for mobile handset, navigation, automotive infotainment, multi-function printer, and next-generation consumer applications. With extended temperature support and high data reliability, offering easy and rapid design integration, the Ferri-eMMC also ideally fits the requirements of point-of-sale terminals, networking and telecommunications equipment, and a variety of leading-edge industrial applications.

## 1.2 Key Features

---

- Industrial Standard Interface
  - JEDEC eMMC Standard Version 5.1 Compliant
- eMMC 5.1 Enhanced Features
  - 11-signal interface (including CMD, CLK, DAT[7:0], and RST\_n)
  - Programmable bus width: 1-bit, 4-bit, and 8-bit
  - Supports HS400 high speed interface timing mode up to 400MB/s data rate
  - Up to 200MHz clock frequency
  - Supports eMMC Field firmware update (FFU)
  - Supports eMMC production state awareness (PSA)
  - Supports eMMC device health report
  - High-speed, Dual Data Rate Boot support
  - Supports Boot and Alternative Boot Mode
  - Replay Protected Memory Block (RPMB)
  - Trim, Sanitize, Discard, Secure Erase, Secure Trim
  - Enhanced Partition Attributes
  - High Priority Interrupt (HPI)
  - Background Operations
  - Enhanced Reliable Write
  - Supports Command Queuing
  - Supports Enhanced Strobe in HS400 Mode
  - Supports eMMC Background Operation Control

- Supports eMMC configuration up to 8 general purpose partitions and 4 RPMB regions
- Supports eMMC CMDQ Enhanced Data Task
- Supports eMMC CMDQ Device Management Operation
  
- Supply Voltage
  - eMMC Interface Power (VCCQ): 1.70–1.95V
  - eMMC Interface Power (VCCQ): 2.7–3.6V<sup>1</sup>
  - NAND Memory Power (VCC): 2.7–3.6V
  
- Dynamic power management technology enables multiple power saving modes
  
- Multiple Densities and Packages
  - Available in 32GB, 64GB, 128GB, 256GB and 512GB full 3D TLC mode density
  - 100-ball and 153-ball standard BGA packages
  - Green Package and RoHS Compliant
  
- Operating Temperature
  - Commercial Grade: -25°C ~ +85°C
  - Industrial Grade: -40°C ~ +85°C
  - Automotive Grade 3: -40°C ~ +85°C
  - Automotive Grade 2: -40°C ~ +105°C

<sup>1</sup> HS200 and HS400 mode are not supported when VCCQ is in 2.7–3.6V.



### 1.3 Block Diagram

Figure 1: Ferri-eMMC Block Diagram

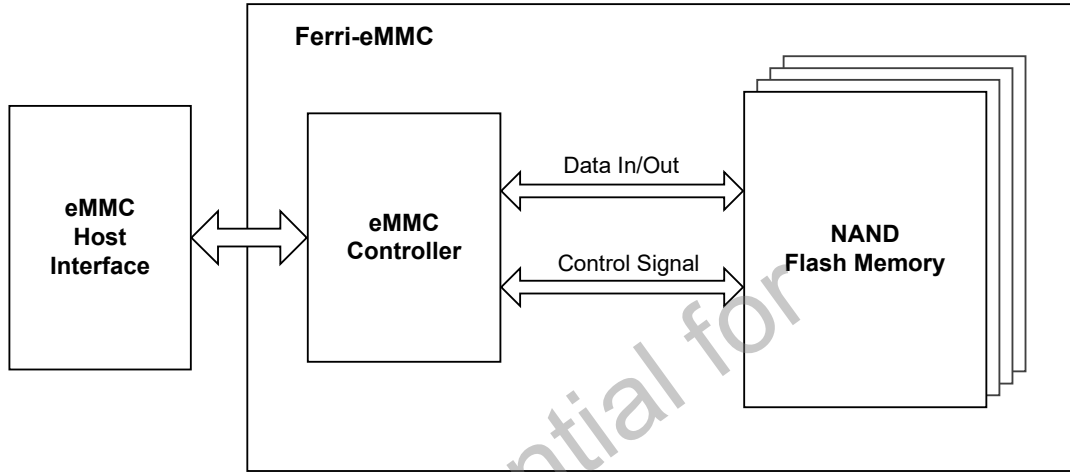

SMI Confidential for  
Digi-Key  
Only

## 2. Pin Assignments and Signal Descriptions

### 2.1 Pin Assignments

Figure 2: 100-Ball Pin Assignments (Top View - Balls Down)

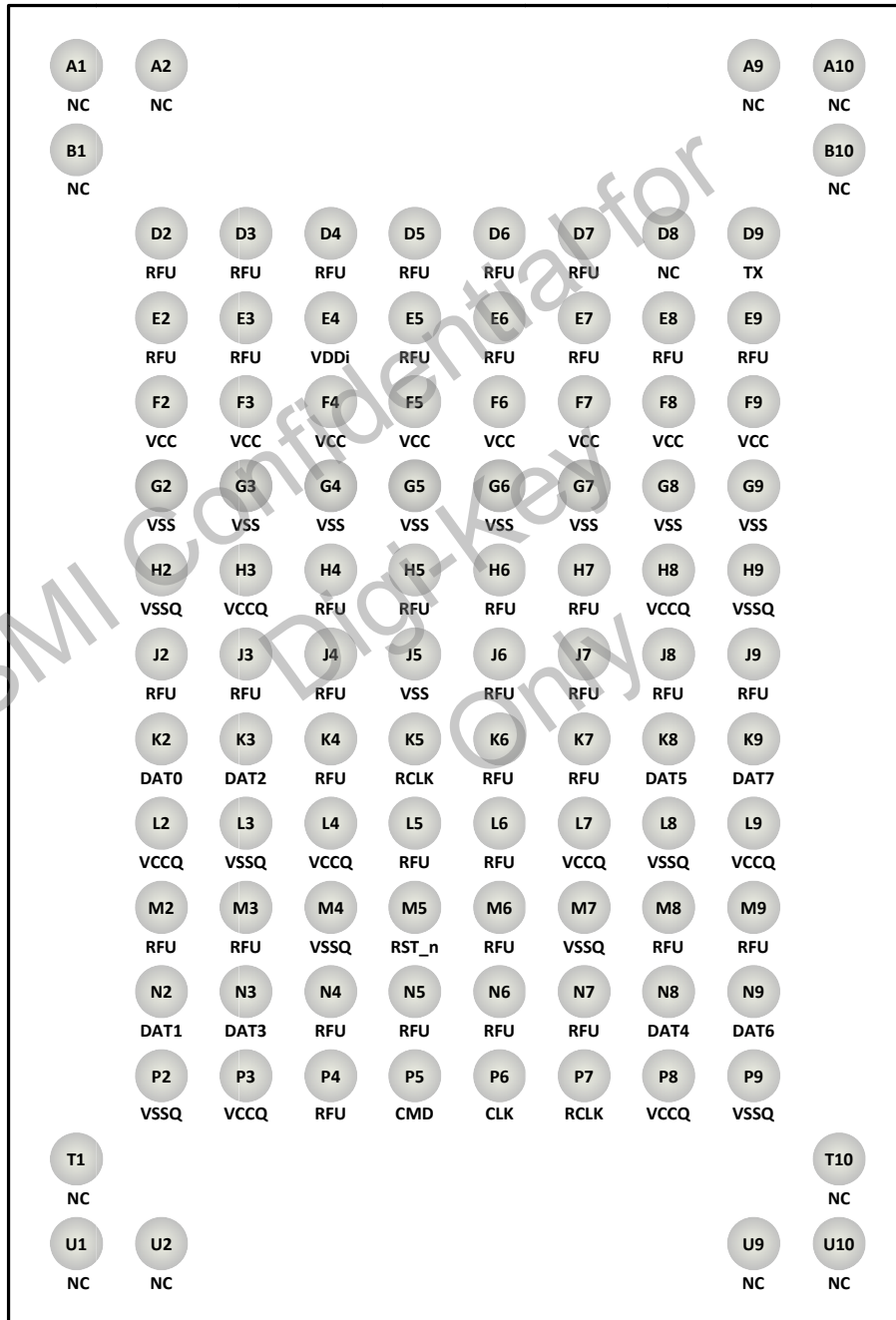

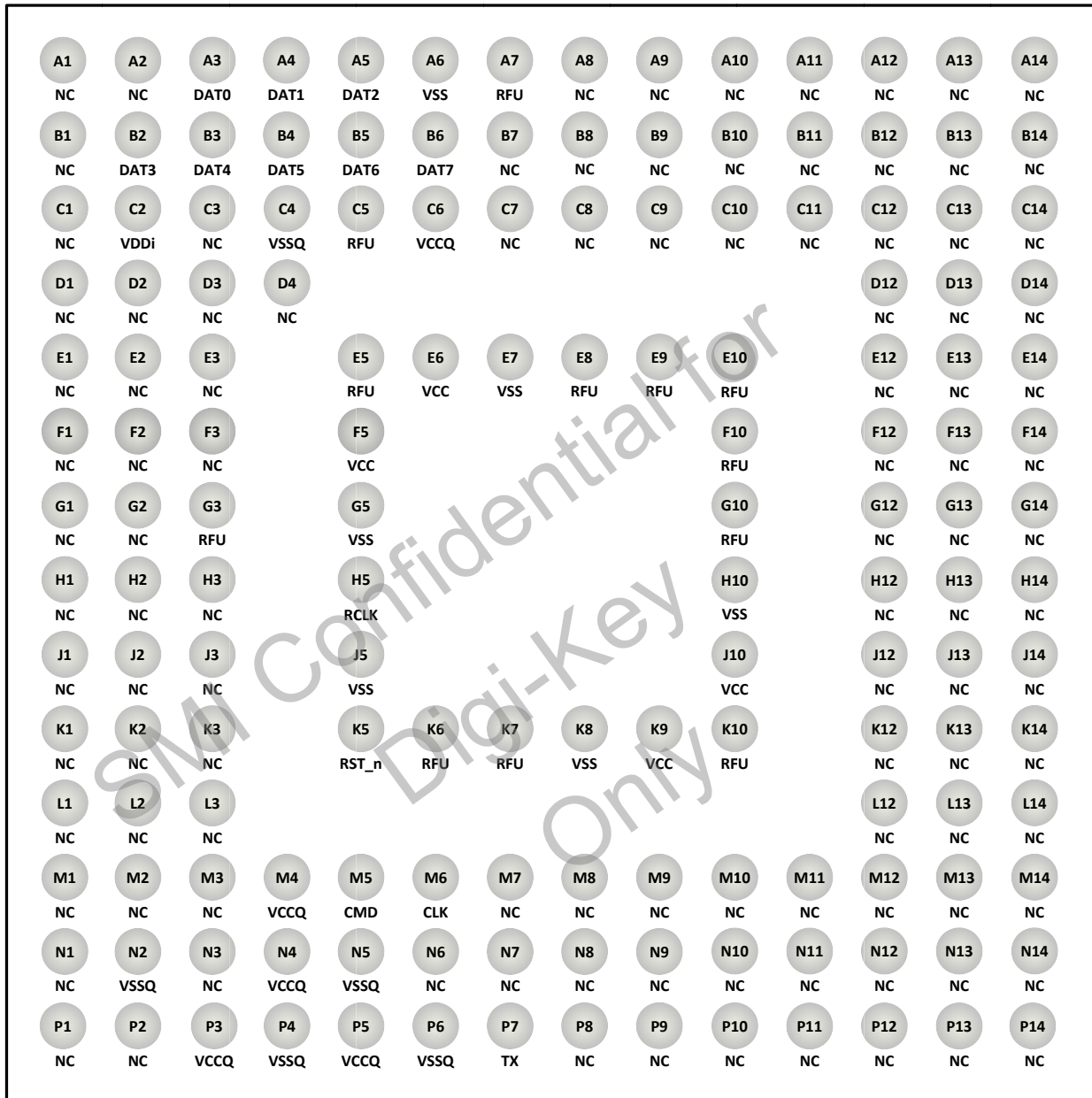
**Figure 3: 153-Ball Pin Assignments (Top View - Balls Down)**

## 2.2 Signal Descriptions

**Table 1: Functional Signals**

Signal	Type	Description
CLK	Input	Clock. Each cycle of the clock directs a transfer on the command line and on the data line(s). The frequency can vary between the minimum and the maximum clock frequency.
RCLK	Output	eMMC interface data strobe (HS400 mode)
CMD	I/O	Command. This signal is a bidirectional command channel used for command and response transfers. The CMD signal has two bus modes: open-drain mode and push-pull mode. Commands are sent from the MMC host to the device, and responses are sent from the device to the host.
DAT0 – DAT7	I/O	Data I/O. These are bidirectional data signals. The DAT signals operate in push-pull mode. By default, after power-up or assertion of the RST_n signal, only DAT0 is used for data transfer. The MMC controller can configure a wider data bus for data transfer using either DAT[3:0] (4-bit mode) or DAT[7:0] (8-bit mode). eMMC includes internal pull-up resistors for data lines DAT[7:1]. Immediately after entering the 4-bit mode, the device disconnects the internal pull-up resistors on the DAT[3:1] lines. Correspondingly, immediately after entering the 8-bit mode, the device disconnects the internal pull-ups on the DAT[7:1] lines.
RST_n	Input	Reset. The RST_n signal is used for host resetting device, moving the device to pre-idle state. By default, the RST_n signal is temporary disabled in device. The host must set bits[1:0] in the extended CSD register [162] to 0x1 to enable this functionality before the host can use it.
VCC	Supply	NAND interface I/O and NAND Flash power supply.
VCCQ	Supply	eMMC controller core and eMMC interface I/O power supply.
VSS	Supply	NAND interface I/O and NAND Flash ground connection.
VSSQ	Supply	eMMC controller core and eMMC interface ground connection.
VDDi	-	Internal voltage node A 1.0uF capacitor is required for VDDi for core power stabilization. Do not tie to supply voltage or ground.
TX	Output	UART Tx output for debug use

Table 2: Miscellaneous Signals

Signal	Type	Description
NC	-	No connect
RFU	-	Reserved for future use. Leave it floating.

SMI Confidential for  
Digi-Key  
Only

## 2.3 Pin List

**Table 3: Pin List of Ferri-eMMC Packages**

Signal	Pin NO. of 100-Ball	Pin NO. of 153-Ball
CLK	P6	M6
RCLK	K5, P7	H5
CMD	P5	M5
DAT0 – DAT7	K2, N2, K3, N3, N8, K8, N9, K9	A3, A4, A5, B2, B3, B4, B5, B6
RST_n	M5	K5
VCC	F2 - F9	E6, F5, J10, K9
VCCQ	H3, H8, L2, L4, L7, L9, P3, P8	C6, M4, N4, P3, P5
VSS	G2 - G9, J5	A6, E7, G5, H10, J5, K8
VSSQ	H2, H9, L3, L8, M4, M7, P2, P9	C4, N2, N5, P4, P6
VDDi	E4	C2
TX	D9	P7
NC	A1, A2, A9, A10, B1, B10, D8, T1, T10, U1, U2, U9, U10	A1, A2, A8 - A14, B1, B7 - B14, C1, C3, C7 - C14, D1 - D4, D12 - D14, E1 - E3, E12 - E14, F1 - F3, F12 - F14, G1, G2, G12 - G14, H1 - H3, H12 - H14, J1 - J3, J12 - J14, K1 - K3, K12 - K14, L1 - L3, L12 - L14, M1 - M3, M7 - M14, N1, N3, N6 - N14, P1, P2, P8 - P14
RFU	D2 - D7, E2, E3, E5 - E9, H4 - H7, J2 - J4, J6 - J9, K4, K6, K7, L5, L6, M2, M3, M6, M8, M9, N4 - N7, P4	A7, C5, E5, E8, E9, E10, F10, G3, G10, K6, K7, K10

### 3. Ferri-eMMC Registers

This chapter introduces the registers for eMMC and the defaulted register values in the Ferri-eMMC. The following table presents the register list of current specification.

Within the device the following registers are defined: OCR, CID, CSD, EXT\_CSD, and RCA. These can be accessed only by corresponding commands (see eMMC specification). The OCR, CID and CSD registers carry the card/content specific information, while the RCA and DSR registers are configuration registers storing actual configuration parameters. The EXT\_CSD register carries both, card specific information and actual configuration parameters.

#### 3.1 CID Register

---

Users can define their own CID (Device IDentification) register by using Silicon Motion's mass production utilities. The CID contents will be programmed into eMMC during the specified flow. After the programming is complete, end users cannot change CID, unless the whole foundry production program is re-done.

#### 3.2 Relative Card Address Register (RCA)

---

The writable 16-bit relative card address register stores the card address. This address is published by the card during card identification, and is used for host-card communication following the card identification procedure. The default value of the RCA register is 0x0001. The value 0x0000 is reserved for setting all cards in the Stand-by State with CMD7.

### 3.3 CSD Register

The Device-Specific Data (CSD) register defines the behavior of eMMC devices. The eMMC behavior is related to the controller design. The following table shows a typical CSD definition of the Ferri-eMMC. If users need to add on more features, firmware or hardware modifications may be necessary.

**Table 4: Ferri-eMMC Typical CSD Register**

Name	Field	Bit	Type	Slice	Value	Note
CSD structure	CSD_STRUCTURE	2	R	[127:126]	3h	
System specification version	SPEC_VERS	4	R	[125:122]	4h	
Reserved	-	2	R	[121:120]	-	
Data read access-time-1	TAAC	8	R	[119:112]	27h	
Data read access-time-2 in CLK cycles (NSAC*100)	NSAC	8	R	[111:104]	01h	
Max. bus clock frequency	TRAN_SPEED	8	R	[103:96]	32h	
Device command classes	CCC	12	R	[95:84]	0F5h	
Max. read data block length	READ_BL_LEN	4	R	[83:80]	9h	
Partial blocks for read allowed	READ_BL_PARTIAL	1	R	[79:79]	0h	
Write block misalignment	WRITE_BLK_MISALIGN	1	R	[78:78]	0h	
Read block misalignment	READ_BLK_MISALIGN	1	R	[77:77]	0h	
DSR implemented	DSR_IMP	1	R	[76:76]	0h	
Reserved	-	2	R	[75:74]	-	
Device size	C_SIZE	12	R	[73:62]	FFFh	
Max. read current at VDD (min)	VDD_R_CURR_MIN	3	R	[61:59]	7h	
Max. read current at VDD (max)	VDD_R_CURR_MAX	3	R	[58:56]	7h	
Max. write current at VDD (min)	VDD_W_CURR_MIN	3	R	[55:53]	7h	
Max. write current at VDD (max)	VDD_W_CURR_MAX	3	R	[52:50]	7h	
Device size multiplier	C_SIZE_MULT	3	R	[49:47]	7h	
Erase group size	ERASE_GRP_SIZE	5	R	[46:42]	1Fh	
Erase group size multiplier	ERASE_GRP_MULT	5	R	[41:37]	1Fh	
Write protect group size	WP_GRP_SIZE	5	R	[36:32]	See Note	512GB: 1Fh 256GB: 1Fh 128GB: 1Fh 64GB: 0Fh 32GB: 0Fh
Write protect group enable	WP_GRP_ENABLE	1	R	[31:31]	1h	
Manufacturer default ECC	DEFAULT_ECC	2	R	[30:29]	0h	
Write speed factor	R2W_FACTOR	3	R	[28:26]	2h	
Max. write data block length	WRITE_BL_LEN	4	R	[25:22]	9h	
Partial blocks for write allowed	WRITE_BL_PARTIAL	1	R	[21:21]	0h	
Reserved	-	4	-	[20:17]	-	
Content protection application	CONTENT_PROT_APP	1	R	[16:16]	0h	
File format group	FILE_FORMAT_GRP	1	R/W	[15:15]	0h	



Name	Field	Bit	Type	Slice	Value	Note
Copy flag (OTP)	COPY	1	R/W	[14:14]	1h	
Permanent write protection	PERM_WRITE_PROTECT	1	R/W	[13:13]	0h	
Temporary write protection	TMP_WRITE_PROTECT	1	R/W/E	[12:12]	0h	
File format	FILE_FORMAT	2	R/W	[11:10]	0h	
ECC code	ECC	2	R/W/E	[9:8]	0h	
CRC	CRC	7	R/W/E	[7:1]	-	
Not used, always '1'	-	1	-	[0:0]	1h	

**Notes:**

- The definitions of cell type are shown as follows:

R: Read only.

W: One time programmable and not readable.

R/W: One time programmable and readable.

W/E: Multiple writable with value kept after power failure, H/W reset assertion and any CMD0 reset and not readable.

R/W/E: Multiple writable with value kept after power failure, H/W reset assertion and any CMD0 reset and readable.

R/W/C\_P: Writable after value cleared by power failure and H/W reset assertion (the value not cleared by CMD0 reset) and readable.

R/W/E\_P: Multiple writable with value reset after power failure, H/W reset assertion and any CMD0 reset and readable.

W/E\_P: Multiple writable with value reset after power failure, H/W reset assertion and any CMD0 reset and not readable.

- Reserved bits should be read as "0".

- The column marked with "-" is undefined.

SMI Confidential for Digi-Key Only

### 3.4 Extended CSD Register (EXT\_CSD)

The Extended CSD register defines the additional behavior of eMMC devices due to limited CSD information. The following table shows a typical extended CSD definition of the Ferri-eMMC. If users need to add on more features, firmware or hardware modifications may be necessary. The register is 512 bytes long. The most significant 320 bytes are the Properties segment, which defines the Device capabilities and cannot be modified by the host. The lower 192 bytes are the Modes segment, which defines the configuration the Device is working in.

**Table 5: Ferri-eMMC Typical EXT\_CSD Register**

Name	Field	Byte	Type	Slice	Value	Note
Reserved	-	6	-	[511:506]	-	
Extended Security Commands Error	EXT_SECURITY_ERR	1	R	[505]	0h	
Supported command sets	S_CMD_SET	1	R	[504]	1h	Allocated by MMCA
HPI features	HPI_FEATURES	1	R	[503]	1h	HPI type CMD13
Background operations support	BKOPS_SUPPORT	1	R	[502]	1h	BKOPS supported
Max packed read commands	MAX_PACKED_READS	1	R	[501]	20h	
Max packed write commands	MAX_PACKED_WRITES	1	R	[500]	20h	
Data Tag Support	DATA_TAG_SUPPORT	1	R	[499]	1h	
Tag Unit Size	TAG_UNIT_SIZE	1	R	[498]	0h	
Tag Resources Size	TAG_RES_SIZE	1	R	[497]	0h	
Context management capabilities	CONTEXT_CAPABILITIES	1	R	[496]	78h	
Large Unit size	LARGE_UNIT_SIZE_M1	1	R	[495]	1h	
Extended partitions attribute support	EXT_SUPPORT	1	R	[494]	3h	
Supported modes	SUPPORTED_MODES	1	R	[493]	1h	
FFU features	FFU_FEATURES	1	R	[492]	0h	
Operation codes timeout	OPERATION_CODE_TIMEOUT	1	R	[491]	17h	
FFU Argument	FFU_ARG	4	R	[490:487]	FFFAFFF0h	
Barrier support	BARRIER_SUPPORT	1	R	[486]	1h	
Reserved	-	177	-	[485:309]	-	
CMD Queuing Support	CMDQ_SUPPORT	1	R	[308]	1h	
CMD Queuing Depth	CMDQ_DEPTH	1	R	[307]	1Fh	
Reserved	-	1	-	[306]	-	
Number of FW sectors correctly programmed	NUMBER_OF_FW_SECTORS_CORRECTLY_PROGRAMMED	4	R	[305:302]	0000h	
Vendor proprietary health report	VENDOR_PROPRIETARY_HEALTH_REPORT	32	R	[301:270]	-	

Name	Field	Byte	Type	Slice	Value	Note
Device life time estimation type B	DEVICE_LIFE_TIME_EST_TYP_B	1	R	[269]	01h	
Device life time estimation type A	DEVICE_LIFE_TIME_EST_TYP_A	1	R	[268]	01h	
Pre EOL information	PRE_EOL_INFO	1	R	[267]	01h	
Optimal read size	OPTIMAL_READ_SIZE	1	R	[266]	40h	
Optimal write size	OPTIMAL_WRITE_SIZE	1	R	[265]	40h	
Optimal trim unit size	OPTIMAL_TRIM_UNIT_SIZE	1	R	[264]	07h	
Device version	DEVICE_VERSION	2	R	[263:262]	See Note	512GB: 05h 256GB: 4505h 128GB: 4405h 64GB: 4305h 32GB: 4205h
Firmware version	FIRMWARE_VERSION	8	R	[261:254]	See Note	00 00 00 00 00 00 00 01
Power class for 200MHz, DDR at VCC=3.6V	PWR_CL_DDR_200_360	1	R	[253]	0h	
Cache size	CACHE_SIZE	4	R	[252:249]	0400h	
Generic CMD6 timeout	GENERIC_CMD6_TIME	1	R	[248]	5h	
Power off notification (long) timeout	POWER_OFF_LONG_TIME	1	R	[247]	64h	
Background operations status	BKOPS_STATUS	1	R	[246]	0h	No operations required
Number of correctly programmed sectors	CORRECTLY_PRG_SECTORS_NUM	4	R	[245:242]	0h	
1 <sup>st</sup> initialization time after partitioning	INI_TIMEOUT_AP	1	R	[241]	0Ah	Initial time out 1s
Cache Flushing Policy	CACHE_FLUSH_POLICY	1	R	[240]	1h	
Power class for 52MHz, DDR at VCC=3.6V	PWR_CL_DDR_52_360	1	R	[239]	0h	RMS 100mA, Peak 200mA
Power class for 52MHz, DDR at VCC=1.95V	PWR_CL_DDR_52_195	1	R	[238]	0h	RMS 65mA, Peak 130mA
Power class for 200MHz at VCCQ=1.95V, VCC=3.6V	PWR_CL_200_195	1	R	[237]	0h	
Power class for 200MHz, at VCCQ=1.3V, VCC=3.6V	PWR_CL_200_130	1	R	[236]	0h	
Minimum write performance for 8bit at 52MHz in DDR mode	MIN_PERF_DDR_W_8_52	1	R	[235]	0h	For cards not reaching the 4.8MB/s value
Minimum read performance for 8bit at 52MHz in DDR mode	MIN_PERF_DDR_R_8_52	1	R	[234]	0h	For cards not reaching the 4.8MB/s value
Reserved	-	1	-	[233]	-	
TRIM multiplier	TRIM_MULT	1	R	[232]	02h	Trim time out 600ms

Name	Field	Byte	Type	Slice	Value	Note
Secure Feature support	SEC_FEATURE_SUPPORT	1	R	[231]	55h	1. Support the secure and insecure trim operations. 2. Support the automatic secure purge operation on retired defective portions of the array. 3. Secure purge operations are supported.
Secure Erase multiplier	SEC_ERASE_MULT	1	R	[230]	See Note	512GB: 0x64 256GB: 0x64 128GB: 0x64 64GB: 0x32 32GB: 0x19
Secure TRIM multiplier	SEC_TRIM_MULT	1	R	[229]	0Ah	
Boot information	BOOT_INFO	1	R	[228]	7h	
Reserved	-	1	-	[227]	-	
Boot partition size	BOOT_SIZE_MULT	1	R	[226]	FCh	
Access size	ACC_SIZE	1	R	[225]	6h	
High-capacity erase unit size	HC_ERASE_GRP_SIZE	1	R	[224]	1h	
High-capacity erase timeout	ERASE_TIMEOUT_MULT	1	R	[223]	2h	
Reliable write sector count	REL_WR_SEC_C	1	R	[222]	10h	
High-capacity write protect group size	HC_WP_GRP_SIZE	1	R	[221]	See Note	512GB: 20h 256GB: 20h 128GB: 20h 64GB: 10h 32GB: 10h
Sleep current (VCC)	S_C_VCC	1	R	[220]	7h	
Sleep current (VCCQ)	S_C_VCCQ	1	R	[219]	7h	
Production state awareness timeout	PRODUCTION_STATE_AWARENESS_TIMEOUT	1	R	[218]	17h	
Sleep/awake timeout	S_A_TIMEOUT	1	R	[217]	12h	
Sleep Notification Timeout	SLEEP_NOTIFICATION_TIME	1	R	[216]	0Ch	
Sector count	SEC_COUNT	4	R	[215:212]	See Note	512GB: 3A40000h 256GB: 1D20000h 128GB: E900000h 64GB: 7340000h 32GB: 39A0000h
Secure Write Protect Information	SECURE_WP_INFO	1	R	[211]	1h	

Name	Field	Byte	Type	Slice	Value	Note
Minimum write performance for 8bit at 52MHz	MIN_PERF_W_8_52	1	R	[210]	0h	
Minimum read performance for 8bit at 52MHz	MIN_PERF_R_8_52	1	R	[209]	0h	
Minimum write performance for 8bit at 26MHz, for 4bit at 52MHz	MIN_PERF_W_8_26_4_52	1	R	[208]	0h	
Minimum read performance for 8bit at 26MHz, for 4bit at 52MHz	MIN_PERF_R_8_26_4_52	1	R	[207]	0h	
Minimum write performance for 4bit at 26MHz	MIN_PERF_W_4_26	1	R	[206]	0h	
Minimum read performance for 4bit at 26MHz	MIN_PERF_R_4_26	1	R	[205]	0h	
Reserved	-	1	-	[204]	-	
Power class for 26MHz at 3.6V 1 R	PWR_CL_26_360	1	R	[203]	0h	
Power class for 52MHz at 3.6V 1 R	PWR_CL_52_360	1	R	[202]	0h	
Power class for 26MHz at 1.95V 1 R	PWR_CL_26_195	1	R	[201]	0h	
Power class for 52MHz at 1.95V 1 R	PWR_CL_52_195	1	R	[200]	0h	
Partition switching timing	PARTITION_SWITCH_TIME	1	R	[199]	4h	
Out-of-interrupt busy timing	OUT_OF_INTERRUPT_TIME	1	R	[198]	Ah	
I/O Driver Strength	DRIVER_STRENGTH	1	R	[197]	1Fh	
Device type	DEVICE_TYPE	1	R	[196]	57h	
Reserved	-	1	-	[195]	-	
CSD STRUCTURE	CSD_STRUCTURE	1	R	[194]	2h	
Reserved	-	1	-	[193]	-	
Extended CSD revision	EXT_CSD_REV	1	R	[192]	8h	
Command set	CMD_SET	1	R/W/E_P	[191]	0h	
Reserved	-	1	-	[190]	-	
Command set revision	CMD_SET_REV	1	R	[189]	0h	
Reserved	-	1	-	[188]	-	
Power class	POWER_CLASS	1	R/W/E_P	[187]	0h	
Reserved	-	1	-	[186]	-	
High-speed interface timing	HS_TIMING	1	R/W/E_P	[185]	0h	
Strobe Support	STROBE_SUPPORT	1	R	[184]	1h	
Bus width mode	BUS_WIDTH	1	W/E_P	[183]	0h	
Reserved	-	1	-	[182]	-	
Erased memory content	ERASED_MEM_CONT	1	R	[181]	0h	

Name	Field	Byte	Type	Slice	Value	Note
Reserved	-	1	-	[180]	-	
Partition configuration	PARTITION_CONFIG	1	R/W/E R/W/E_P	[179]	0h	
Boot config protection	BOOT_CONFIG_PROT	1	R/W R/W/C_P	[178]	0h	
Boot bus conditions	BOOT_BUS_CONDITIONS	1	R/W/E	[177]	0h	
Reserved	-	1	-	[176]	-	
High-density erase group definition	ERASE_GROUP_DEF	1	R/W/E	[175]	0h	
Boot write protection status registers	BOOT_WP_STATUS	1	R	[174]	0h	
Boot area write protection register	BOOT_WP	1	R/W R/W/C_P	[173]	0h	
Reserved	-	1	-	[172]	-	
User area write protection register	USER_WP	1	R/W R/W/C_P R/W/E_P	[171]	0h	
Reserved	-	1	-	[170]	-	
FW configuration	FW_CONFIG	1	R/W	[169]	0h	
RPMB size	RPMB_SIZE_MULT	1	R	[168]	20h	
Write reliability setting register	WR_REL_SET	1	R/W	[167]	1Fh	
Write reliability parameter register	WR_REL_PARAM	1	R	[166]	15h	
Start Sanitize operation	SANITIZE_START	1	W/E_P	[165]	0h	
Manually start background operations	BKOPS_START	1	W/E_P	[164]	0h	
Enable background operations handshake	BKOPS_EN	1	R/W	[163]	0h	
H/W reset function	RST_n_FUNCTION	1	R/W	[162]	0h	
HPI_management	HPI_MGMT	1	R/W/E_P	[161]	0h	
Partitioning support	PARTITIONING_SUPPORT	1	R	[160]	7h	
Max enhanced area size	MAX_ENH_SIZE_MULT	3	R	[159:157]	See Note	512GB: 26D5h 256GB: 136Ah 128GB: 9B5h 64GB: 99Ah 32GB: 4CDh
Partitions attribute	PARTITIONS_ATTRIBUTE	1	R/W	[156]	0h	
Partitioning setting	PARTITION_SETTING_COMPLETED	1	R/W	[155]	0h	
General purpose partition size	GP_SIZE_MULT	12	R/W	[154:143]	0h	
Enhanced user data area size	ENH_SIZE_MULT	3	R/W	[142:140]	0h	
Enhanced user data start address	ENH_START_ADDR	4	R/W	[139:136]	0h	

Name	Field	Byte	Type	Slice	Value	Note
Reserved	-	1	-	[135]	-	
Bad block management mode	SEC_BAD_BLK_MGMNT	1	R/W	[134]	0h	
Production state awareness	PRODUCTION_STATE_AWARENESS	1	R/W/E	[133]	0h	
Package Case Temperature is controlled	TCASE_SUPPORT	1	W/E_P	[132]	0h	
Periodic Wake-up	PERIODIC_WAKEUP	1	R/W/E	[131]	0h	
Program CID/CSD in DDR mode support	PROGRAM_CID_CSD_DDR_SUPPORT	1	R	[130]	0h	
Reserved	-	2	-	[129:128]	-	
Vendor Specific Fields	VENDOR_SPECIFIC_FIELD	64	<vendor specific>	[127:64]	-	
Native sector size	NATIVE_SECTOR_SIZE	1	R	[63]	1h	
Sector size emulation	USE_NATIVE_SECTOR	1	R/W	[62]	0h	
Sector size	DATA_SECTOR_SIZE	1	R	[61]	0h	
1 <sup>st</sup> initialization after disabling sector size emulation	INI_TIMEOUT_EMU	1	R	[60]	0Ah	
Class 6 commands control	CLASS_6_CTRL	1	R/W/E_P	[59]	0h	
Number of addressed group to be Released	DYNCAP_NEEDED	1	R	[58]	0h	
Exception events control	EXCEPTION_EVENTS_CTRL	2	R/W/E_P	[57:56]	00h	
Exception events status	EXCEPTION_EVENTS_STATUS	2	R	[55:54]	00h	
Extended Partitions Attribute	EXT_PARTITIONS_ATTRIBUTE	2	R/W	[53:52]	00h	
Context configuration	CONTEXT_CONF	15	R/W/E_P	[51:37]	0h	
Packed command status	PACKED_COMMAND_STATUS	1	R	[36]	0h	
Packed command failure index	PACKED_FAILURE_INDEX	1	R	[35]	0h	
Power Off Notification	POWER_OFF_NOTIFICATION	1	R/W/E_P	[34]	0h	
Control to turn the Cache ON/OFF	CACHE_CTRL	1	R/W/E_P	[33]	0h	
Flushing of the cache	FLUSH_CACHE	1	W/E_P	[32]	0h	
Control to turn the Barrier ON/OFF	BARRIER_CTRL	1	R/W	[31]	0h	
Mode config	MODE_CONFIG	1	R/W/E_P	[30]	0h	
Mode operation codes	MODE_OPERATION_CODES	1	W/E_P	[29]	0h	
Reserved	-	2	-	[28:27]	-	
FFU status	FFU_STATUS	1	R	[26]	0h	
Pre loading data size	PRE_LOADING_DATA_SIZE	4	R/W/E_P	[25:22]	0h	

Name	Field	Byte	Type	Slice	Value	Note
Max pre loading data size	MAX_PRE_LOADING_DATA_SIZE	4	R	[21:18]	See Note	512GB: 136A8000h 256GB: 9B50000h 128GB: 4DA8000h 64GB: 2668000h 32GB: 1334000h
Product state awareness enablement	PRODUCT_STATE_AWARENESS_ENABLEMENT	1	R/W/E & R	[17]	01h	
Secure Removal Type	SECURE_REMOVAL_TYPE	1	R/W & R	[16]	3Bh	
Command Queue Mode Enable	CMDQ_MODE_EN	1	R/W/E_P	[15]	0h	
Reserved	-	15	-	[14:0]	-	

**Notes:**

1. The definitions of cell type are shown as follows:

R: Read only.

W: One time programmable and not readable.

R/W: One time programmable and readable.

W/E: Multiple writable with value kept after power failure, H/W reset assertion and any CMD0 reset and not readable.

R/W/E: Multiple writable with value kept after power failure, H/W reset assertion and any CMD0 reset and readable.

R/W/C\_P: Writable after value cleared by power failure and H/W reset assertion (the value not cleared by CMD0 reset) and readable.

R/W/E\_P: Multiple writable with value reset after power failure, H/W reset assertion and any CMD0 reset and readable.

W/E\_P: Multiple writable with value reset after power failure, H/W reset assertion and any CMD0 reset and not readable.

2. Reserved bits should be read as "0".

3. The column marked with "-" is undefined.



## 4. DC Electrical Characteristics

**Table 6: Operating Conditions**

Parameter	Symbol	Min	Max	Unit
Supply Voltage (NAND)	VCC	2.7	3.6	V
Supply Voltage (I/O)	VCCQ	1.7	1.95	V
		2.7	3.6	V
Supply Power-up for 3.3V	tPRUH		35	ms
Supply Power-up for 1.8V	tPRUL		25	ms
Operating Temperature (Commercial Grade)	T <sub>OPR</sub>	-25	+85	°C
Operating Temperature (Industrial Grade)	T <sub>OPR</sub>	-40	+85	°C
Operating Temperature (Automotive Grade 3)	T <sub>OPR</sub>	-40	+85	°C
Operating Temperature (Automotive Grade 2)	T <sub>OPR</sub>	-40	+105	°C

**Table 7: Absolute Maximum Ratings**

Parameter	Symbol	Min	Max	Unit
Voltage Input	V <sub>IN</sub>	-0.3	4.0	V
VCC Supply	VCC	-0.3	4.0	V
VCCQ Supply	VCCQ	-0.3	4.0	V
Storage Temperature (Commercial Grade)	T <sub>STG</sub>	-25	+85	°C
Storage Temperature (Industrial Grade)	T <sub>STG</sub>	-40	+105	°C
Storage Temperature (Automotive Grade 3)	T <sub>STG</sub>	-40	+85	°C
Storage Temperature (Automotive Grade 2)	T <sub>STG</sub>	-40	+105	°C

In the Ferri-eMMC, VCC is used for the NAND flash device; and VCCQ is for the controller and the eMMC interface voltage. A  $C_{Reg}$  capacitor must be connected to the VDDi terminal to stabilize regulator output on the system.

Figure 4: Internal Power Diagram (Example)

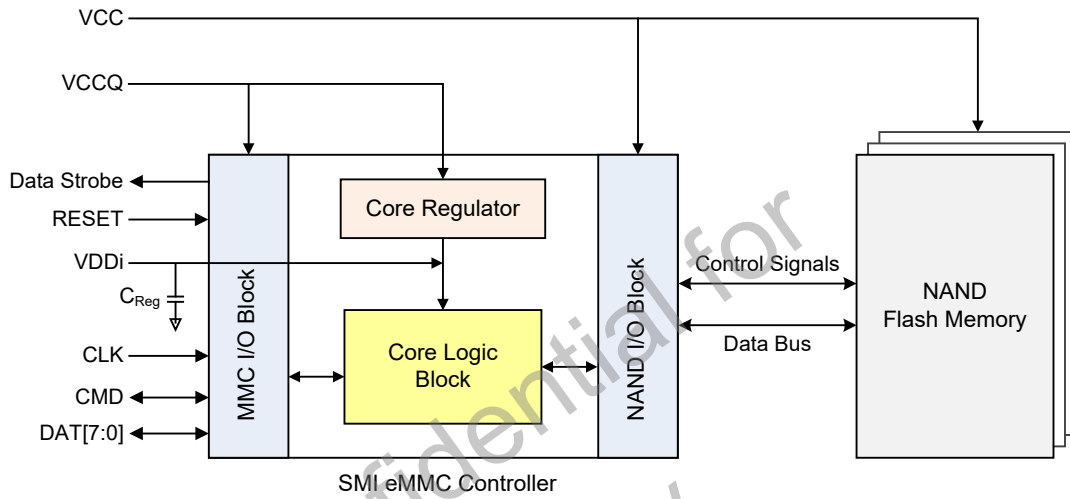

SMI Confidential for Digi-Key Only

## 5. Ordering Information

### 5.1 Product Coding Rule

**Table 8: Product Code Definitions**

Example: SM 6 6 2 P E F BE S	
SM	Silicon Motion
66	Ferri-eMMC Family
2	Interface and Type <ul style="list-style-type: none"> <li>• 2 = eMMC5.1 TLC</li> </ul>
P	Package <ul style="list-style-type: none"> <li>• G = 100-ball BGA</li> <li>• P = 153-ball BGA</li> </ul>
E	Operating Temperature <ul style="list-style-type: none"> <li>• X = -25°C ~ +85°C (commercial grade)</li> <li>• E = -40°C ~ +85°C (industrial grade)</li> <li>• A = -40°C ~ +85°C (automotive grade 3)</li> <li>• B = -40°C ~ +105°C (automotive grade 2)</li> </ul>
F	Capacity <ul style="list-style-type: none"> <li>• B = 32GB</li> <li>• C = 64GB</li> <li>• D = 128GB</li> <li>• E = 256GB</li> <li>• F = 512GB</li> </ul>
BE	Product Revision
S	NAND Vendor Code <ul style="list-style-type: none"> <li>• □ = T</li> <li>• S</li> </ul>

**Note:** For Ferri-eMMC ordering part numbers please refer to the Product Selection Guide.

## 5.2 Top Marking

Figure 5: SM662GX(E)B/C/D/E/F Top Marking (Example)

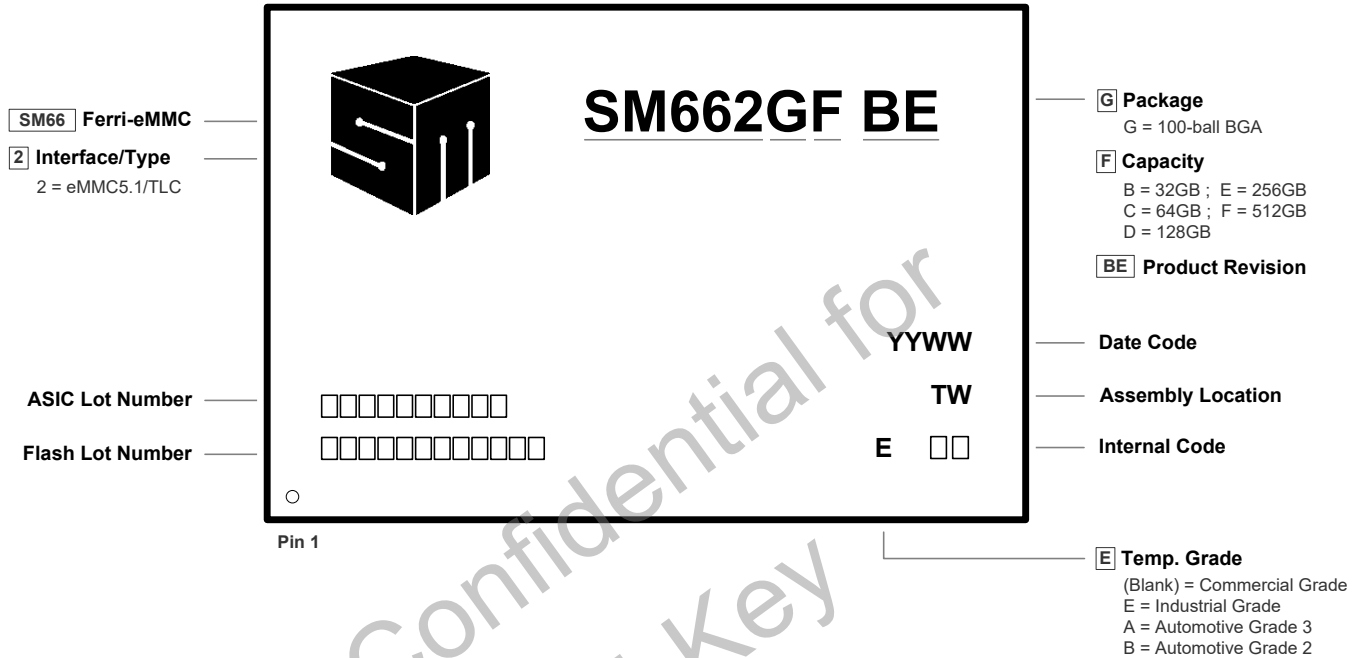

Figure 6: SM662PX(E)F Top Marking (Example)

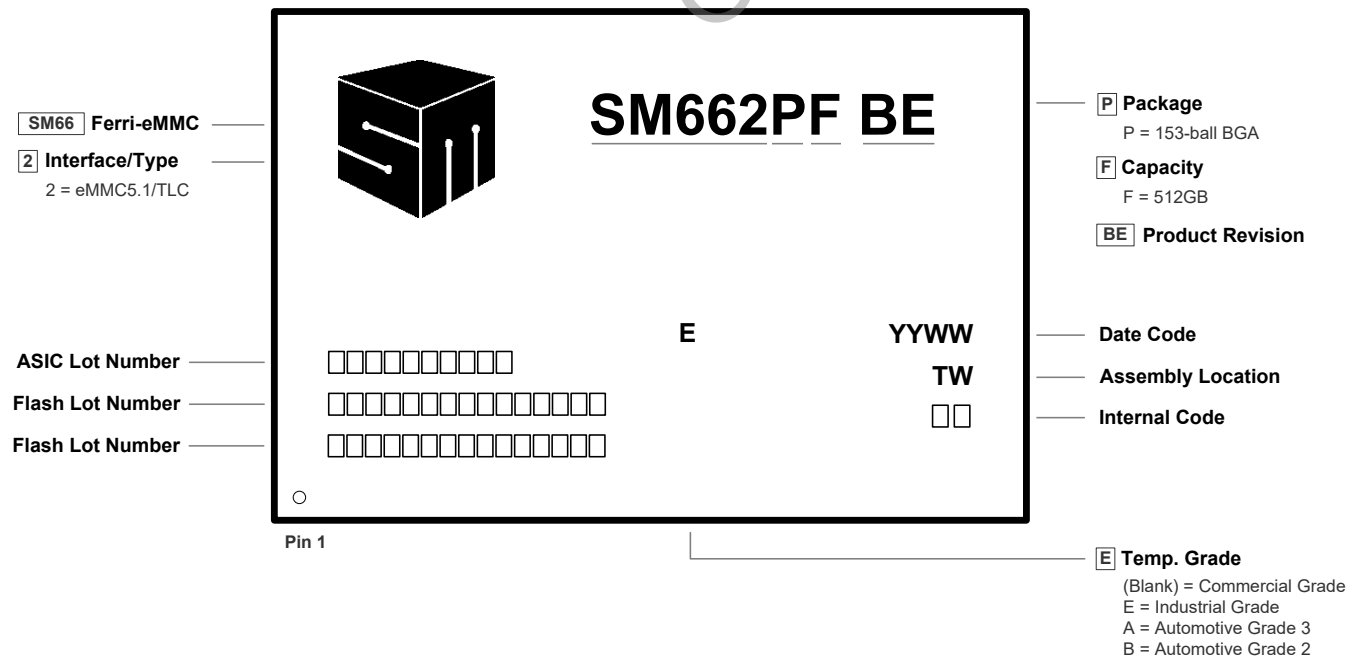
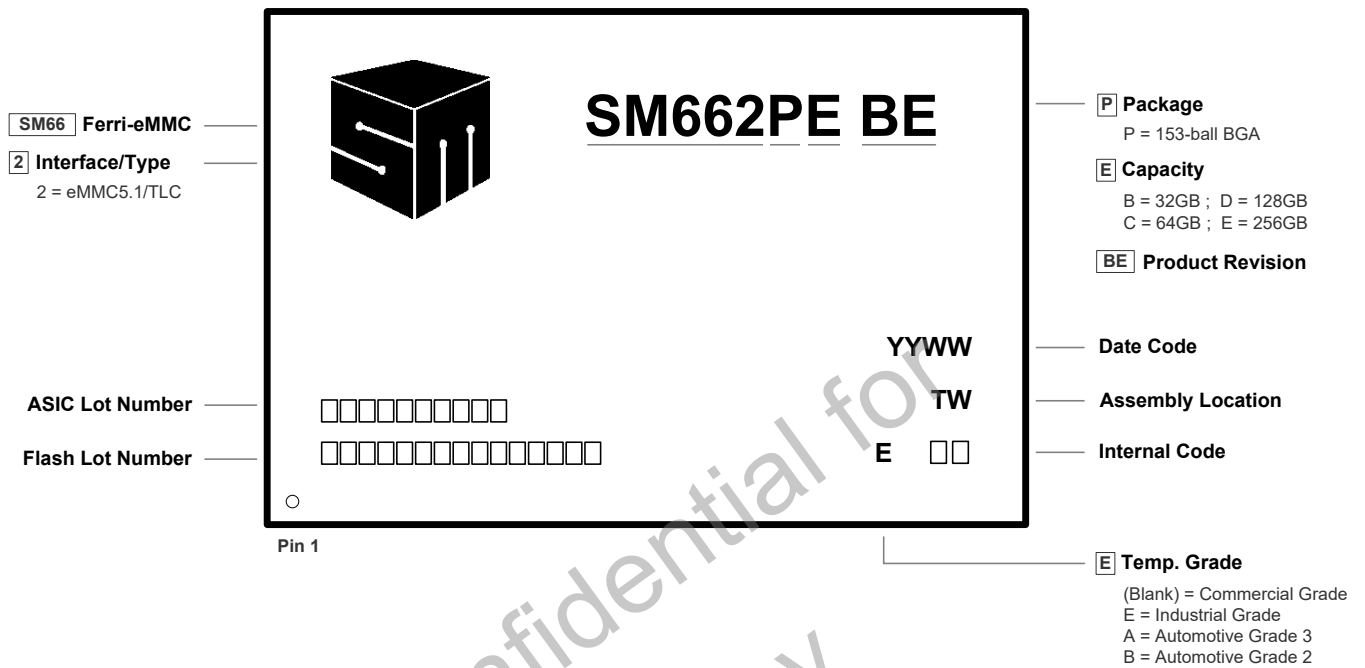

Figure 7: SM662PX(E)B/C/D/E Top Marking (Example)



SMI Confidential for Digi-Key Only