



A New Direction in Mixed-Signal

January 2014

Rev. 1.0.1

XRP9710 and XRP9711

Dual 6A Programmable Power Module

GENERAL DESCRIPTION

The XRP9710 and XRP9711 are programmable step down power modules providing two 6A outputs. The module package contains the switching controller, power MOSFETs, inductors and support components. As a result, external components are minimal. A wide input voltage range (4.75V to 5.5V or 5.5V to 22V) allows for single supply operation from standard power rails.

The modules measure only 12x12x2.75mm making it half the size of competing 12V capable 6Amp modules. The 2.75mm height allows them to be placed on the back of boards or under heat sinks where other solutions cannot, yet they contain two full 6A buck power stages and two Digital Pulse Width Modulator (DPWM) controllers with gate drivers. Designed to operate at a constant PWM switching frequency between 500kHz and 750kHz, the Digital Pulse Frequency Mode (DPFM) results in better than 80% efficiency at light load currents and low operating current allow for portable and Energy Star compliant applications. Each XRP9710 or XRP9711 output can be individually programmed to as low as 0.6V with a resolution as fine as 2.5mV, and configurable for precise soft start and soft stop sequencing, including delay and ramp control.

The XRP9710/1 is fully controlled via a SMBus-compliant I²C interface allowing for advanced local and/or remote reconfiguration, full performance monitoring and reporting as well as fault handling.

Built-in output over-voltage, over-temperature, over-current and under voltage lockout protections insure safe operation under abnormal operating conditions.

The XRP9710/1 is offered in a RoHS compliant, halogen-free LGA package.

FEATURES

- **XRP9710 – Dual 6A Outputs with Differential Sensing**
- **XRP9711 – Dual 6A Outputs with Control for Two External Power Stages**
- **12 x 12 x 2.75mm LGA Package**
- **Wide Input Voltage Range: 4.75V to 22V**
 - Low Range: 4.75V to 5.5V
 - High Range: 5.5V-22V
- **Output Voltage Range: 0.6V to 5.5V**
- **SMBus Compliant - I²C Interface**
 - Full Power Monitoring and Reporting
- **3 x 15V Capable PSIOs + 2 x GPIOs**
- **Full Start/Stop Sequencing Support**
- **Built-in Thermal, Over-Current, UVLO and Output Over-Voltage Protections**
- **On-Board 5V Standby LDO**
- **On-Board Non-volatile Memory**
- **CISPR22 Level B radiated emissions**
- **PowerArchitect™ 5.1 or later Design Tool**

APPLICATIONS

- **Servers**
- **Base Stations**
- **Switches/Routers**
- **Broadcast Equipment**
- **Industrial Control Systems**
- **Automatic Test Equipment**
- **Video Surveillance Systems**



A New Direction in Mixed-Signal

January 2014

XRP9710 and XRP9711

Dual 6A Programmable Power Module

Rev. 1.0.1

TYPICAL APPLICATION DIAGRAM

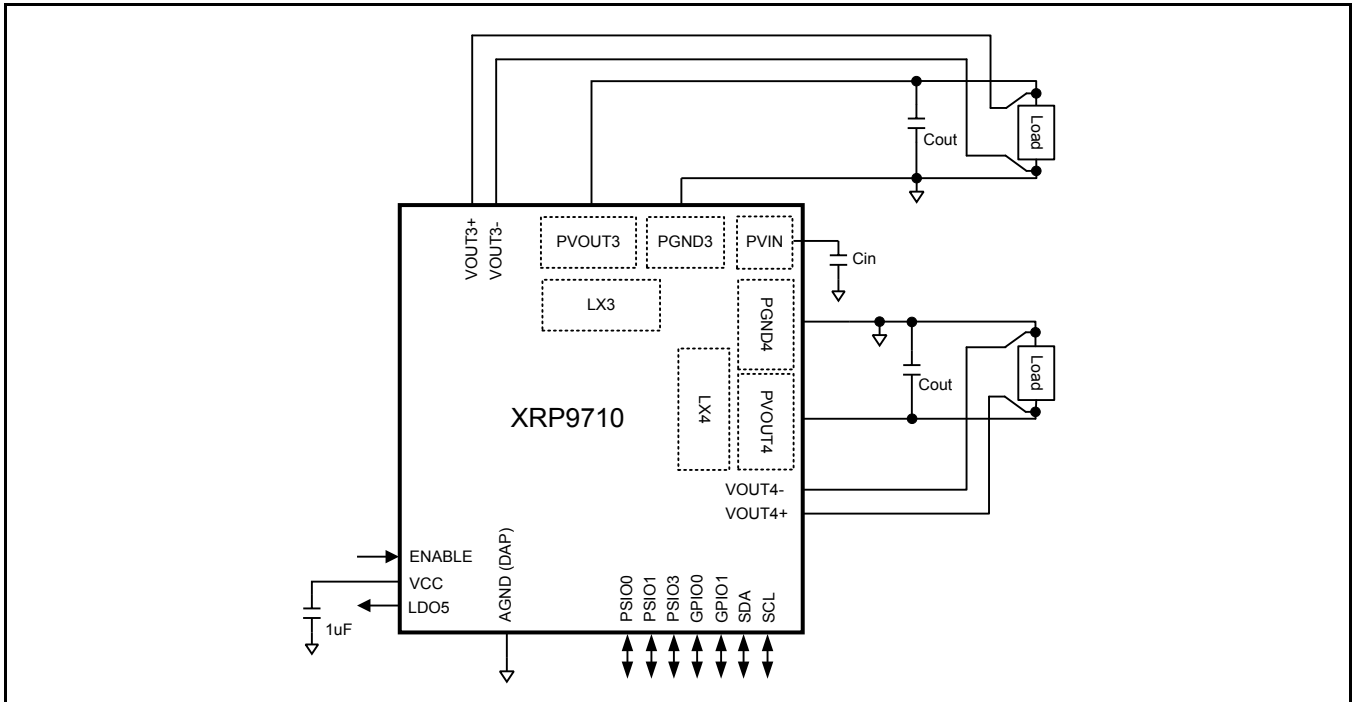

Figure 1 XRP9710 Application Diagram with differential voltage sensing

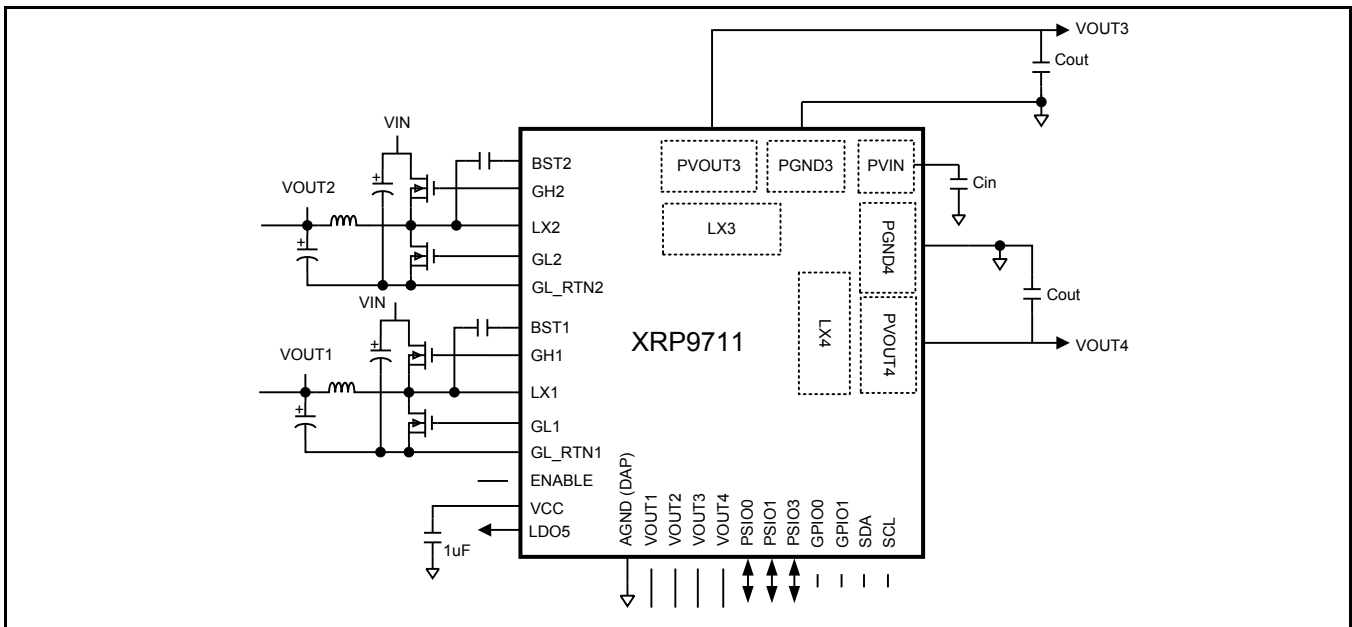

Figure 2 XRP9711 Application Diagram



A New Direction in Mixed-Signal

XRP9710 and XRP9711

Dual 6A Programmable Power Module

FEATURES AND BENEFITS

World's smallest 12V capable dual 6A module at 12x12x2.75mm

Programmable Power Benefits

- **Fully Configurable**
 - Output set point
 - Feedback compensation
 - Frequency set point
 - Under voltage lock out
 - Input voltage measurement
 - Gate drive dead time
- **Reduced Development Time**
 - Configurable and re-configurable for different V_{out} , I_{out} , C_{out} , and Inductor values
 - No need to change external passives for a new output specification.
- **Higher integration and Reliability**
 - Lowest component count for a fully configurable module

PowerArchitect™ 5 Design and Configuration Software

- Wizard quickly generates a base design
- Calculates all configuration registers
- Projects can be saved and/or recalled
- GPIOs can be configured easily and intuitively
- "Dashboard" Interface can be used for real-time monitoring and debug

System Benefits

- Reliability is enhanced via communication with the system controller which can obtain real-time data on an output voltage, input voltage and current.
- System processors can communicate with the XRP9710/1 directly to obtain data or make adjustments to react to circuit conditions
- System logging and history, diagnostics and remote reconfigurability.

System Integration Capabilities

- **Single supply operation**
- **I²C interface allows:**
 - Communication with a System Controller or other Power Management devices for optimized system functionality
 - Access to modify or read internal registers that control or monitor:
 - Output Current
 - Input and Output Voltage
 - Soft-Start/Soft-Stop Time
 - 'Power Good'
 - Part Temperature
 - Enable/Disable Outputs
 - Over Current
 - Over Voltage
 - Temperature Faults
 - Adjusting fault limits and disabling/enabling faults
 - Packet Error Checking (PEC) on I²C communication
- **5 GPIO pins with a wide range of configurability**
 - Fault reporting (including UVLO Warn/Fault, OCP Warn/Fault, OVP, Temperature, Soft-Start in progress, Power Good, System Reset)
 - Allows a Logic Level interface with other non-digital IC's or as logic inputs to other devices
- **Frequency and Synchronization Capability**
 - Selectable switching frequency between 124kHz and 1.23MHz (500kHz to 750kHz internal power stages)
 - Main oscillator clock and DPWM clock can be synchronized to external sources
- **Internal MOSFET Drivers (XRP9711)**
 - Internal FET drivers (4Ω/2Ω) per channel
 - Built-In Automatic Dead-time adjustment
 - 17ns Rise and 11ns Fall times



ABSOLUTE MAXIMUM RATINGS

These are stress ratings only and functional operation of the device at these ratings or any other above those indicated in the operation sections of the specifications below is not implied. Exposure to absolute maximum rating conditions for extended periods of time may affect reliability.

LDO5, GLx, VOUTx -0.3V to 7.0V
 ENABLE -0.3V to 7.0V
 GPIO0/1, SCL, SDA 6.0V
 PSIO Inputs 18V
 V_{CC} 28V
 LXx -1V to 28V
 BSTx, GHx VLXx + 6V
 Storage Temperature -65°C to 150°C
 Power Dissipation Internally Limited
 Lead Temperature (Soldering, 10 sec) 245°C
 ESD Rating (HBM - Human Body Model) 2kV

OPERATING RATINGS

Input Voltage Range V_{CC} 5.5V to 25V
 PVIN Voltage Range 3.0 to 22V
 Input Voltage Range V_{CC} = LDO5 4.75V to 5.5V
 VOUT1, 2, 3, 4 5.5V
 Junction Temperature Range -40°C to 125°C
 Package Power Dissipation max at 25°C 5.5W
 JEDEC51-2A Package Thermal Resistance θ_{JA} 18°C/W
 Complies with CISPR22 Level B

ELECTRICAL SPECIFICATIONS

Specifications with standard type are for an Operating Junction Temperature of T_J = 25°C only; limits applying over the full Operating Junction Temperature range are denoted by a "•". Typical values represent the most likely parametric norm at T_J = 25°C, and are provided for reference purposes only. Unless otherwise indicated, V_{CC} = 5.5V to 22V.

QUIESCENT CURRENT

Parameter	Min.	Typ.	Max.	Units	Conditions
V _{CC} Supply Current in SHUTDOWN		10	20	μA	EN = 0V, V _{CC} = 12V
ENABLE Turn On Threshold	0.82		0.95	V	V _{CC} = 12V Enable Rising
ENABLE Pin Leakage Current			10	uA	EN=5V
	-10				EN=0V
V _{CC} Supply Current in STANDBY		440	600	μA	All channels disabled GPIOs programmed as inputs V _{CC} =12V, EN = 5V
V _{CC} Supply Current 2ch PFM		3.1		mA	2 channels on set at 5V, VOUT forced to 5.1V, no load, non-switching, Ultra-sonic off, V _{CC} =12 V, No I ² C activity.
V _{CC} Supply Current 4ch PFM		4.0		mA	4 channels on set at 5V, VOUT forced to 5.1V, no load, non-switching, Ultra-sonic off, V _{CC} =12V, No I ² C activity.
V _{CC} Supply Current ON		18		mA	All channels enabled, F _{sw} =600kHz, gate drivers unloaded, No I ² C activity.

INPUT VOLTAGE RANGE AND UNDERVOLTAGE LOCKOUT

Parameter	Min.	Typ.	Max.	Units	Conditions
V _{CC} Range	5.5		25	V	•
	4.75		5.5	V	• With V _{CC} connected to LDO5
PVIN Range	3.0		22	V	•



VOLTAGE FEEDBACK ACCURACY AND OUTPUT VOLTAGE SET POINT RESOLUTION

Parameter	Min.	Typ.	Max.	Units	Conditions
VOUT Regulation Accuracy Low Output Range 0.6V to 1.6V PWM Operation	-5 -20 -7.5 -22.5		5 20 7.5 22.5	mV mV mV mV	• • • • $0.6 \leq V_{OUT} \leq 1.6V$ $V_{CC}=LDO5$
VOUT Regulation Accuracy Mid Output Range 0.6V to 3.2V PWM Operation	-15 -45 -20 -50		15 45 20 50	mV mV mV mV	• • • • $0.6 \leq V_{OUT} \leq 3.2V$ $0.6 \leq V_{OUT} \leq 3.2V$ $V_{CC}=LDO5$
VOUT Regulation Accuracy High Output Range 0.6V to 5.5V PWM Operation	-30 -90 -40 -100		30 90 40 100	mV mV mV mV	• • • • $0.6 \leq V_{OUT} \leq 5.5V$ $0.6 \leq V_{OUT} \leq 4.2V$ $V_{CC}=LDO5$
VOUT Regulation Range	0.6		5.5	V	• Without external divider network
VOUT Native Set Point Resolution		12.5 25 50		mV	Low Range Mid Range High Range
VOUT Fine Set Point Resolution ¹		2.5 5 10		mV	Low Range Mid Range High Range
VOUT Input Resistance		120 90 75		k Ω	Low Range Mid Range High Range
VOUT Input Resistance in PFM Operation		10 1 0.67		M Ω	Low Range Mid Range High Range
Power Good and OVP Set Point Range (from set point)	-155 -310 -620		157.5 315 630	mV	Low Range Mid Range High Range
Power Good and OVP Set Point Accuracy	-5 -10 -20		5 10 20	mV	Low Range Mid Range High Range

Note 1: Fine Set Point Resolution not available in PFM

CURRENT AND AUX ADC (MONITORING ADCs)

Parameter	Min.	Typ.	Max.	Units		Conditions
Current Sense Accuracy	-3.75	±1.25	3.75	mV		Low Range ($\leq 120\text{mV}$)
	-10		10	mV	•	-60mV applied
	-5	±2.5	5	mV		High Range ($\leq 280\text{mV}$)
	-12.5		+12.5	mV	•	-150mV
Current Sense ADC INL		±0.4		LSB		
DNL		0.27				
Current Limit Set Point Resolution and Current Sense ADC Resolution		1.25		mV		Low Range ($\leq 120\text{mV}$)
		2.5		mV		High Range ($\leq 280\text{mV}$)
Current Sense ADC Range	-120		20	mV		Low Range ($\leq 120\text{mV}$)
	-280		40			High Range ($\leq 280\text{mV}$)
VOUT ADC Resolution		15 30 60		mV		Low Range Mid Range High Range
VOUT ADC Accuracy	-1		1	LSB		
V _{CC} ADC Range	4.6		25	V		Note 2
UVLO WARN SET	4.4		4.72	V		UVLO WARN set point 4.6V, V _{CC} =LDO5
UVLO WARN CLEAR	4.4		4.72	V		UVLO WARN set point 4.6V, V _{CC} =LDO5
V _{CC} ADC Resolution		200		mV		
V _{CC} ADC Accuracy	-1		1	LSB		V _{CC} \leq 20V
Die Temp ADC Resolution		5		°C		
Die Temp ADC Range	-44		156	°C		Output value is in Kelvin

Note 2: Although Range of V_{CC} ADC is technically 0V to 25V, below 4.55 the LDO5 hardware UVLO may have tripped.

LINEAR REGULATOR

Parameter	Min.	Typ.	Max.	Units		Conditions
LDO5 Output Voltage	4.85	5.0	5.15	V	•	$5.5\text{V} \leq V_{CC} \leq 25\text{V}$ $0\text{mA} < I_{LDO5OUT} < 130\text{mA}$
LDO5 Current Limit	135	155	180	mA	•	LDO5 Fault Set
LDO5 UVLO	4.74			V	•	V _{CC} Rising
LDO5 PGOOD Hysteresis		375		mV		V _{CC} Falling
Maximum total LDO loading during ENABLE start-up			30	mA		ENABLE transition from logic low to high. Once LDO5 in regulation above limits apply.



A New Direction in Mixed-Signal

XRP9710 and XRP9711

Dual 6A Programmable Power Module

PWM GENERATORS AND OSCILLATOR

Parameter	Min.	Typ.	Max.	Units	Conditions
Switching Frequency (fsw) Range, Channels 1 and 2	124		1230	kHz	See Applications Information
Switching Frequency (fsw) Range, Channels 3 and 4	500		750	kHz	
fsw Accuracy	-5		5	%	
CLOCK IN Synchronization Frequency	20	25.7	31	MHz	When synchronizing to an external clock (Range 1)
CLOCK IN Synchronization Frequency	10	12.8	15.5	MHz	When synchronizing to an external clock (Range 2)

GPIOs³

Parameter	Min.	Typ.	Max.	Units	Conditions
Input Pin Low Level			0.8	V	
Input Pin High Level	2.0			V	
Input Pin Leakage Current			1	μA	
Output Pin Low Level			0.4	V	I _{SINK} = 1mA
Output Pin High Level	2.4			V	I _{SOURCE} = 1mA
Output Pin High Level		3.3	3.6	V	I _{SOURCE} = 0mA
Output Pin High-Z leakage Current (GPIO pins only)			10	μA	
Maximum Sink Current			1	mA	Open Drain Mode
I/O Frequency			30	MHz	I/O configured for clock synchronization input or output

Note 3: 3.3V CMOS logic compatible, 5V tolerant.

PSIOs⁴

Parameter	Min.	Typ.	Max.	Units	Conditions
Input Pin Low Level			0.8	V	
Input Pin High Level	2.0			V	
Input Pin Leakage Current			1	μA	
Output Pin Low Level			0.4	V	I _{SINK} = 3mA
Output Pin High Level			15	V	Open Drain. External pull-up resistor to user supply
Output Pin High-Z leakage Current (PSIO pins only)			10	μA	
I/O Frequency			5	MHz	

Note 4: 3.3V/5.0V CMOS logic compatible, maximum rating of 15.0V



A New Direction in Mixed-Signal

XRP9710 and XRP9711

Dual 6A Programmable Power Module

SMBUS (I²C) INTERFACE

Parameter	Min.	Typ.	Max.	Units	Conditions
Input Pin Low Level, V_{IL}			0.3 VIO	V	VIO = 3.3 V \pm 10%
Input Pin High Level, V_{IH}	0.7 VIO			V	VIO = 3.3 V \pm 10%
Hysteresis of Schmitt Trigger inputs, V_{hys}	0.05 VIO			V	VIO = 3.3 V \pm 10%
Output Pin Low Level (open drain or collector), V_{OL}			0.4	V	$I_{SINK} = 3mA$
Input leakage current	-10		10	μA	Input is between 0.1 VIO and 0.9 VIO
Output fall time from V_{IHmin} to V_{ILmax}	20 + 0.1 Cb		250	ns	With a bus capacitance (Cb) from 10 pF to 400 pF
Internal Pin Capacitance			1	pF	

GATE DRIVERS

Parameter	Min.	Typ.	Max.	Units	Conditions
GH, GL Rise Time		17		ns	At 10-90% of full scale, 1nF C_{load}
GH, GL Fall Time		11		ns	
GH, GL Pull-Up On-State Output Resistance		4	5	Ω	
GH, GL Pull-Down On-State Output Resistance		2	2.5	Ω	
GH, GL Pull-Down Resistance in Off-Mode		50		k Ω	$V_{CC} = V_{CCD} = 0V.$
Bootstrap diode forward resistance		9		Ω	@ 10mA
Minimum On Time		50		ns	1nF of gate capacitance.
Minimum Off Time		125		ns	1nF of gate capacitance
Minimum Programmable Dead Time		20		ns	Does not include dead time variation from driver output stage Tsw=switching period
Maximum Programmable Dead Time		Tsw			
Programmable Dead Time Adjustment Step		607		ps	



A New Direction in Mixed-Signal

XRP9710 and XRP9711

Dual 6A Programmable Power Module

BLOCK DIAGRAMS

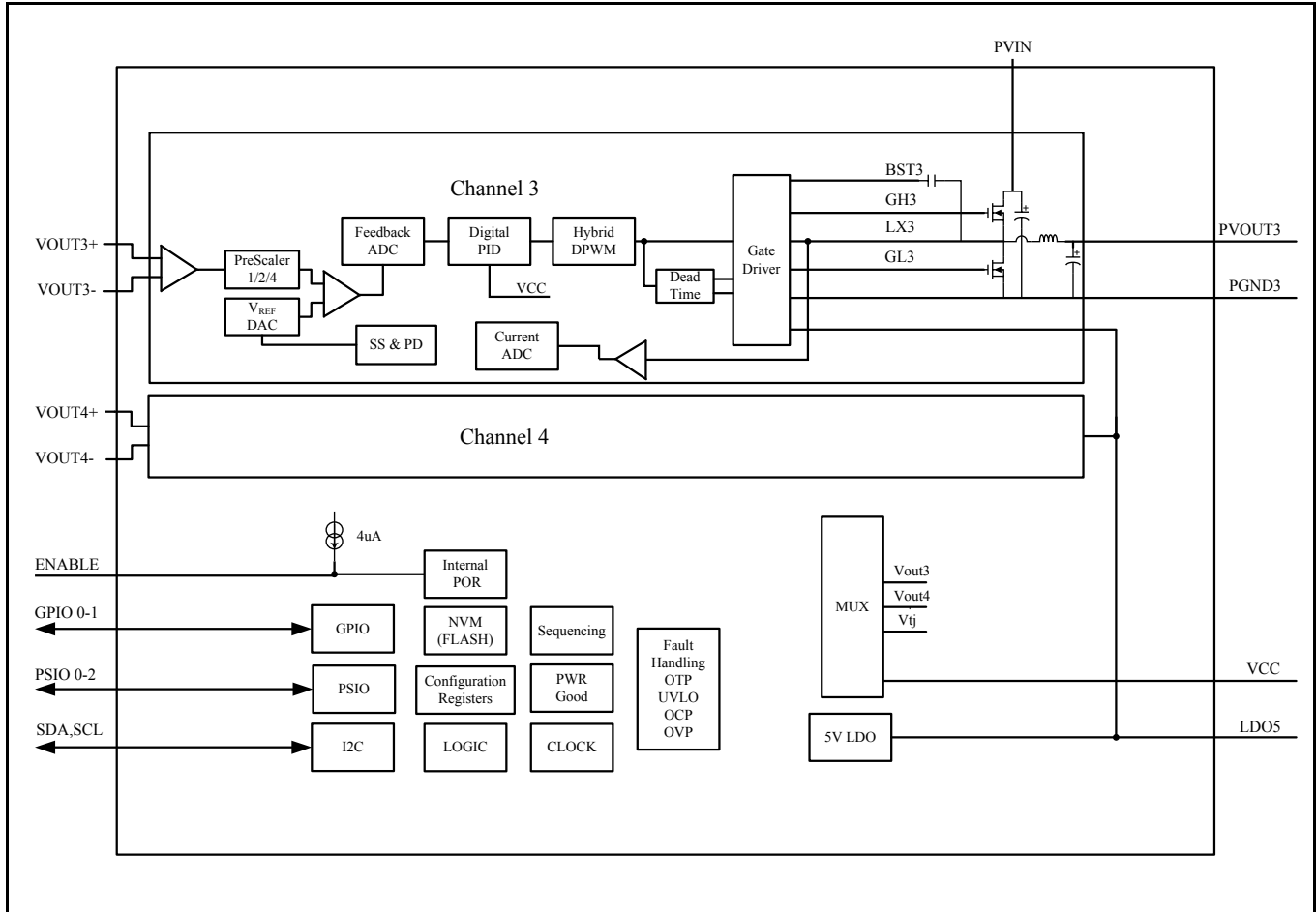

Figure 3 XRP9710 Block Diagram



A New Direction in Mixed-Signal

XRP9710 and XRP9711

Dual 6A Programmable Power Module

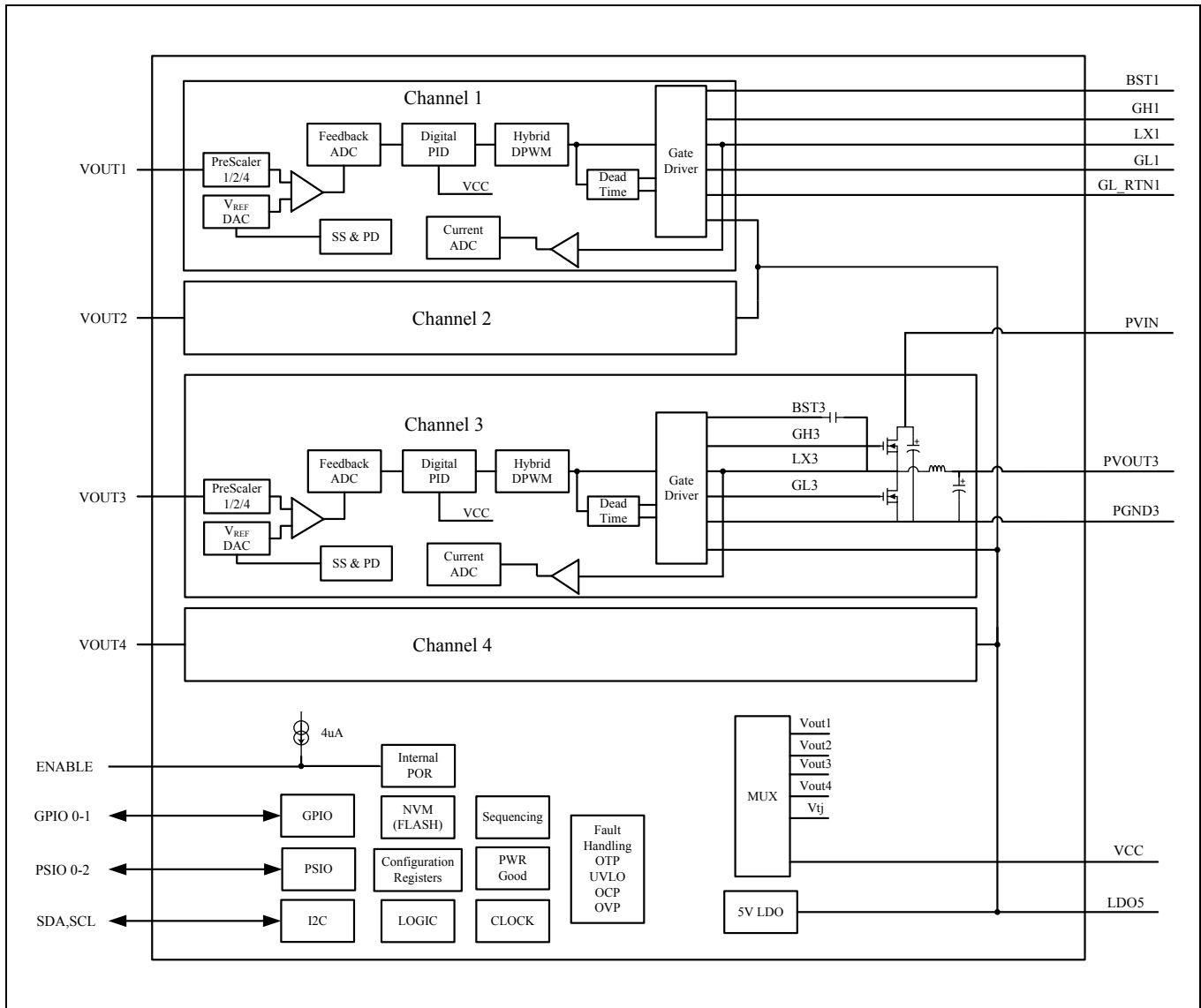

Figure 4 XRP9711 Block Diagram



A New Direction in Mixed-Signal

XRP9710 and XRP9711

Dual 6A Programmable Power Module

XRP9710 PIN ASSIGNMENT

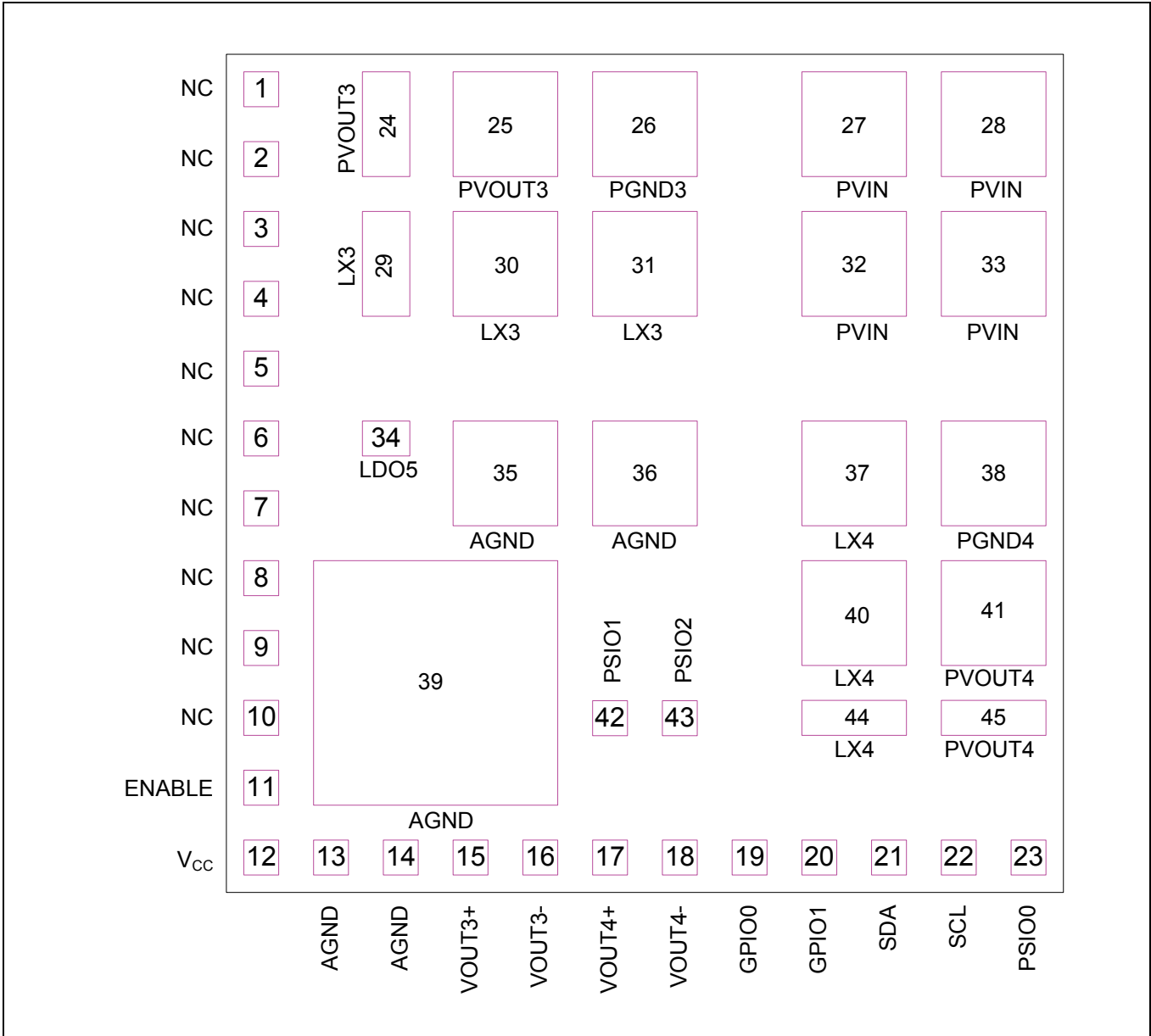

Figure 5 XRP9710 Pin Assignment, Top View



A New Direction in Mixed-Signal

XRP9710 and XRP9711

Dual 6A Programmable Power Module

XRP9710 PIN DESCRIPTION

Pin #	Name	Description
1-10	NC	No Connect
11	ENABLE	Enable. If ENABLE is pulled high or allowed to float high, the chip is powered up. The pin must be held low for the XRP9710 to be placed into shutdown.
12	V _{CC}	Controller Supply Voltage. Place a decoupling capacitor close to the controller IC. This input is used in UVLO fault generation.
13	AGND	Analog Ground. This is the small signal ground connection.
14	AGND	Analog Ground. This is the small signal ground connection.
15	VOUT3+	Feedback Pin. Positive input of remote sensing differential amplifier. Connect to the remote voltage load, positive terminal.
16	VOUT3-	Feedback Pin. Negative input of remote sensing differential amplifier. Connect to the remote voltage load, negative terminal.
17	VOUT4+	Feedback Pin. Positive input of remote sensing differential amplifier. Connect to the remote voltage load, positive terminal.
18	VOUT4-	Feedback Pin. Negative input of remote sensing differential amplifier. Connect to the remote voltage load, negative terminal.
19	GPIO0	I/O Logic Signal. Can be configured as input or output.
20	GPIO1	I/O Logic Signal. Can be configured as input or output.
21	SDA	I²C Data. SMBus/I ² C serial interface communication.
22	SCL	I²C Clock. SMBus/I ² C serial interface communication.
23	PSIO0	I/O Logic Signal, HV. Open drain, high voltage compliant. Can be configured as input or output.
24	PVOUT3	Channel Output Power. Output voltage for the internal channel.
25	PVOUT3	Channel Output Power. Output voltage for the internal channel.
26	PGND3	Channel Output Ground. Output ground for the internal channel.
27	PVIN	Channel Input Power. Internally connected to drain of upper switching MOSFET
28	PVIN	Channel Input Power. Internally connected to drain of upper switching MOSFET
29	LX3	Switch Node. Switch node of the internal channel.
30	LX3	Switch Node. Switch node of the internal channel.
31	LX3	Switch Node. Switch node of the internal channel.
32	PVIN	Channel Input Power. Internally connected to drain of upper switching MOSFET
33	PVIN	Channel Input Power. Internally connected to drain of upper switching MOSFET
34	LDO5	5V LDO Output. Used internally for power and may also be used for external power. LDO that can remain active while the rest of the IC is in standby mode.
35	AGND	Analog Ground. This is the small signal ground connection.
36	AGND	Analog Ground. This is the small signal ground connection.
37	LX4	Switch Node. Switch node of the internal channel.
38	PGND4	Channel Output Ground. Output ground for the internal channel.
39	AGND	Analog Ground. This is the small signal ground connection.
40	LX4	Switch Node. Switch node of the internal channel.
41	PVOUT4	Channel Output Power. Output voltage for the internal channel.
42	PSIO1	I/O Logic Signal, HV. Open drain, high voltage compliant. Can be configured as input or output.
43	PSIO2	I/O Logic Signal, HV. Open drain, high voltage compliant. Can be configured as input or output.
44	LX4	Switch Node. Switch node of the internal channel.
45	PVOUT4	Channel Output Power. Output voltage for the internal channel.



A New Direction in Mixed-Signal

XRP9710 and XRP9711

Dual 6A Programmable Power Module

XRP9711 PIN ASSIGNMENT

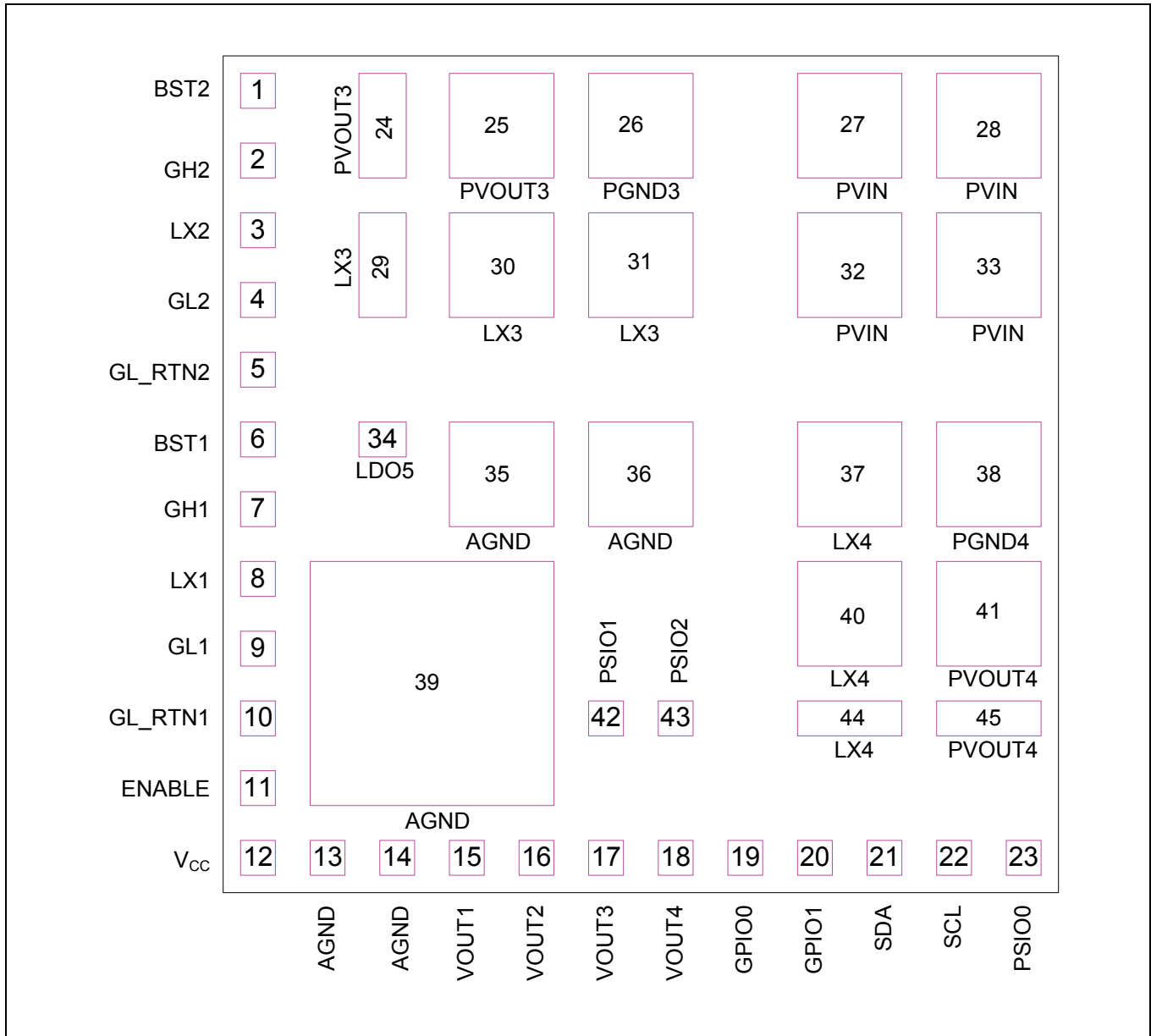

Figure 6 XRP9711 Pin Assignment, Top View



XRP9711 PIN DESCRIPTION

Pin #	Name	Description
1	BST2	Boost pin. High side driver supply input.
2	GH2	High Side Gate Drive Out. Connect directly to the gate of an external N-channel MOSFET.
3	LX2	Switch Node. Return for the high-side gate driver. Connect directly to the drain of the lower FET. Also used to measure voltage drop across bottom MOSFETs
4	GL2	Low Side Gate Drive Out. Connect directly to the gate of an external N-channel MOSFET.
5	GL_RTN2	Low Side Gate Drive Return. This should be routed as a differential trace with GL. Connect to the source of the low side MOSFET.
6	BST1	Boost pin. High side driver supply input.
7	GH1	High Side Gate Drive Out. Connect directly to the gate of an external N-channel MOSFET.
8	LX1	Switch Node. Return for the high-side gate driver. Connect directly to the drain of the lower FET. Also used to measure voltage drop across bottom MOSFETs
9	GL1	Low Side Gate Drive Out. Connect directly to the gate of an external N-channel MOSFET.
10	GL_RTN1	Low Side Gate Drive Return. This should be routed as a differential trace with GL. Connect to the source of the low side MOSFET.
11	ENABLE	Enable. If ENABLE is pulled high or allowed to float high, the chip is powered up. The pin must be held low for the XRP9711 to be placed into shutdown.
12	V _{cc}	Controller Supply Voltage. Place a decoupling capacitor close to the controller IC. This input is used in UVLO fault generation.
13	AGND	Analog Ground. This is the small signal ground connection.
14	AGND	Analog Ground. This is the small signal ground connection.
15	VOUT1	Feedback Pin. Connect to the output of the corresponding power stage
16	VOUT2	Feedback Pin. Connect to the output of the corresponding power stage
17	VOUT3	Feedback Pin. Connect to the output of the corresponding power stage
18	VOUT4	Feedback Pin. Connect to the output of the corresponding power stage
19	GPIO0	I/O Logic Signal. Can be configured as input or output.
20	GPIO1	I/O Logic Signal. Can be configured as input or output.
21	SDA	I²C Data. SMBus/I ² C serial interface communication.
22	SCL	I²C Clock. SMBus/I ² C serial interface communication.
23	PSIO0	I/O Logic Signal, HV. Open drain, high voltage compliant. Can be configured as input or output.
24	PVOUT3	Channel Output Power. Output voltage for the internal channel.
25	PVOUT3	Channel Output Power. Output voltage for the internal channel.
26	PGND3	Channel Output Ground. Output ground for the internal channel.
27	PVIN	Channel Input Power. Internally connected to drain of upper switching MOSFET
28	PVIN	Channel Input Power. Internally connected to drain of upper switching MOSFET
29	LX3	Switch Node. Switch node of the internal channel.
30	LX3	Switch Node. Switch node of the internal channel.
31	LX3	Switch Node. Switch node of the internal channel.
32	PVIN	Channel Input Power. Internally connected to drain of upper switching MOSFET
33	PVIN	Channel Input Power. Internally connected to drain of upper switching MOSFET
34	LDO5	5V LDO Output. Used internally for power and may also be used for external power. LDO that can remain active while the rest of the IC is in standby mode.
35	AGND	Analog Ground. This is the small signal ground connection.
36	AGND	Analog Ground. This is the small signal ground connection.
37	LX4	Switch Node. Switch node of the internal channel.
38	PGND4	Channel Output Ground. Output ground for the internal channel.
39	AGND	Analog Ground. This is the small signal ground connection.
40	LX4	Switch Node. Switch node of the internal channel.
41	PVOUT4	Channel Output Power. Output voltage for the internal channel.



A New Direction in Mixed-Signal

XRP9710 and XRP9711

Dual 6A Programmable Power Module

Pin #	Name	Description
42	PSIO1	I/O Logic Signal, HV. Open drain, high voltage compliant. Can be configured as input or output.
43	PSIO2	I/O Logic Signal, HV. Open drain, high voltage compliant. Can be configured as input or output.
44	LX4	Switch Node. Switch node of the internal channel.
45	PVOUT4	Channel Output Power. Output voltage for the internal channel.

ORDERING INFORMATION

Part Number	Temperature Range	Marking	Package	Packing Quantity	Note 1	I ² C Default Address
XRP9710EY-F	-40°C ≤ T _J ≤ +125°C	9710EY FWWYY Lot #	12x12mm LGA	Tray	Halogen Free	0x28 (7Bit)
XRP9710EYTR-F				2.5K/Tape & Reel		
XRP9711EY-F		9711EY FWWYY Lot #		Tray		
XRP9711EYTR-F				2.5K/Tape & Reel		
XRP9710EVB-DEMO-1-KIT		Evaluation kit includes XRP9710EVB-DEMO-1 Evaluation Board with Power Architect software and controller board				
XRP9711EVB-DEMO-1-KIT		Evaluation kit includes XRP9711EVB-DEMO-1 Evaluation Board with Power Architect software and controller board				

"F" denotes "-F" part number suffix - "YY" = Year - "WW" = Work Week



A New Direction in Mixed-Signal

XRP9710 and XRP9711

Dual 6A Programmable Power Module

TYPICAL PERFORMANCE CHARACTERISTICS

All data taken at $V_{CC} = 12V$, $T_J = T_A = 25^\circ C$, unless otherwise specified - Schematic and BOM from XRP9711EVB. See XRP9711EVB-DEMO-1 Manual.

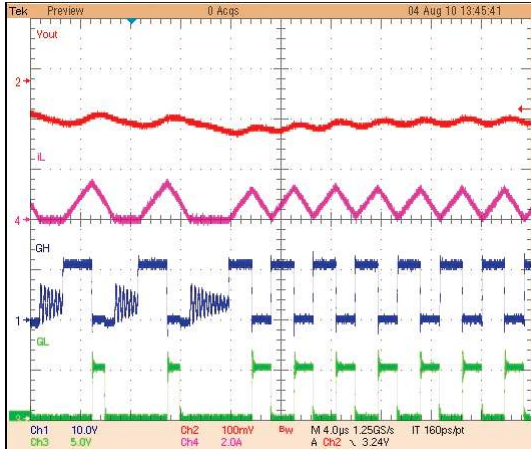

Figure 7 PFM to PWM Transition

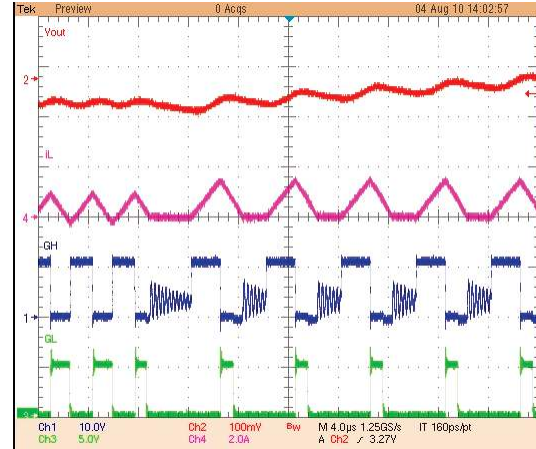

Figure 8 PWM to PFM Transition

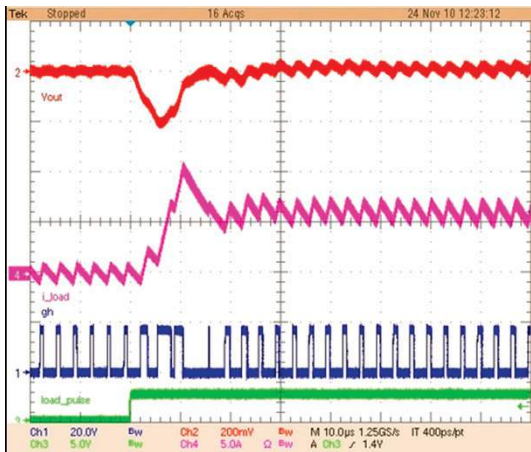

Figure 9 0-6A Transient 300kHz PWM only

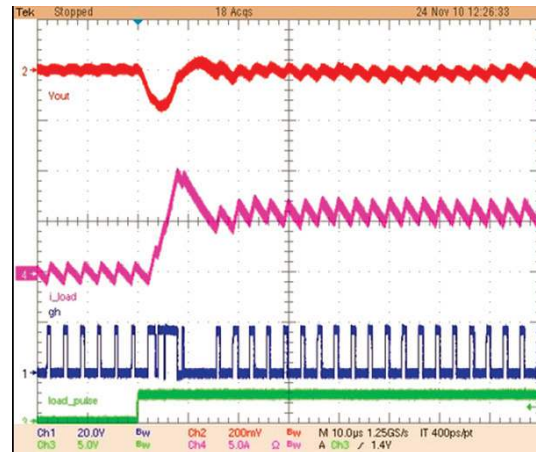

Figure 10 0-6A Transient 300kHz with OVS $\pm 5.5\%$

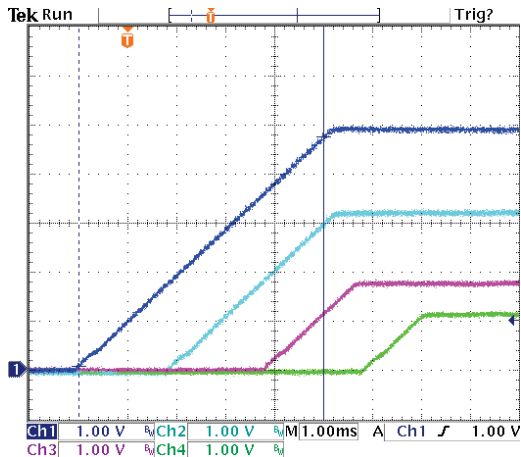

Figure 11 Sequential Start-up

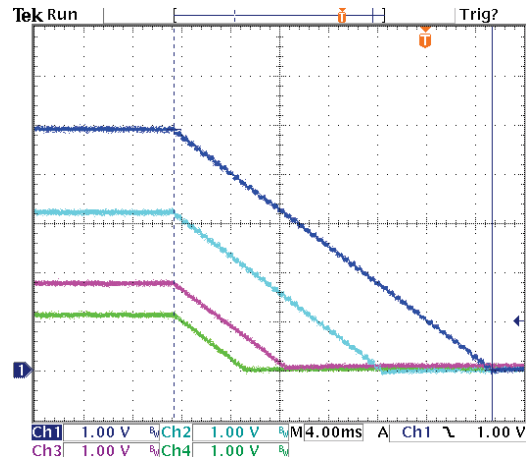

Figure 12 Sequential Shut Down



A New Direction in Mixed-Signal

XRP9710 and XRP9711 Dual 6A Programmable Power Module

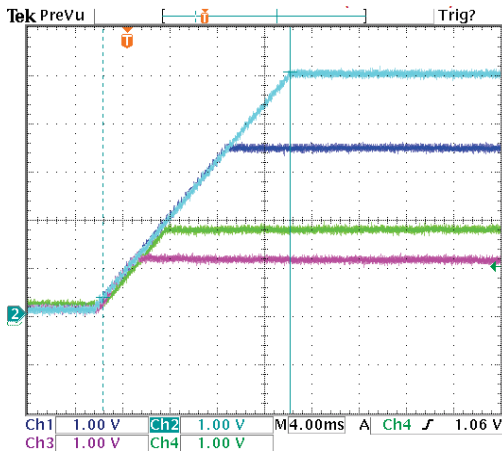

Figure 13 Simultaneous Start-up

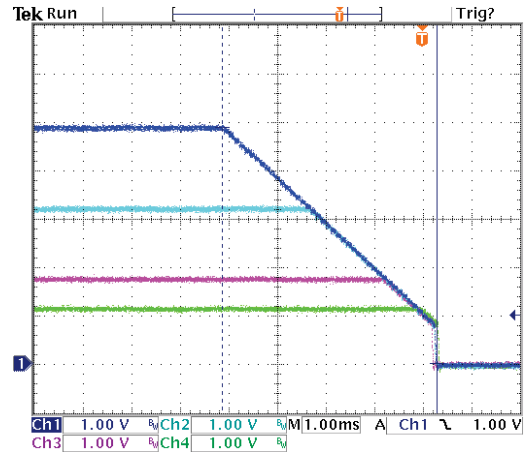

Figure 14 Simultaneous Shut Down

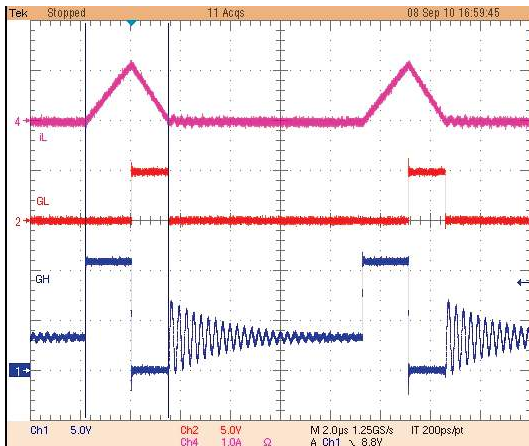

Figure 15 PFM Zero Current Accuracy

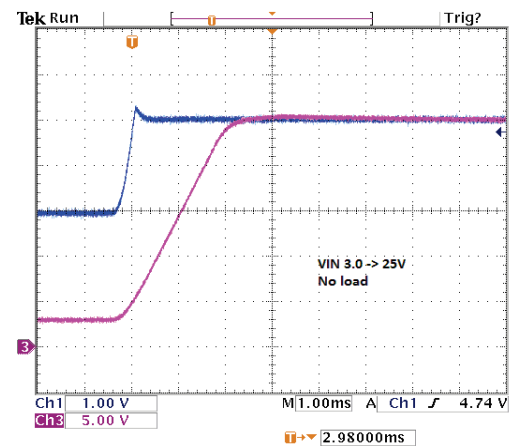

Figure 16 LDO5 Brown Out Recovery, No Load

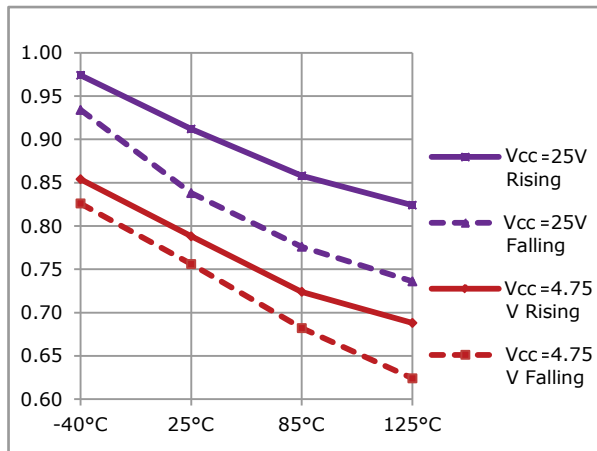

Figure 17 Enable Threshold Over Temp

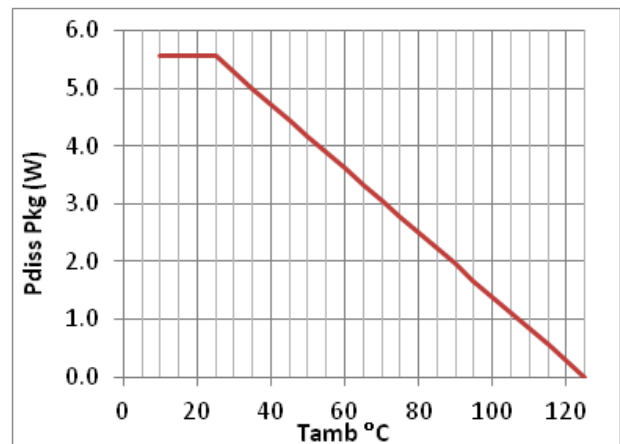

Figure 18 Package Thermal Derating



A New Direction in Mixed-Signal

XRP9710 and XRP9711

Dual 6A Programmable Power Module

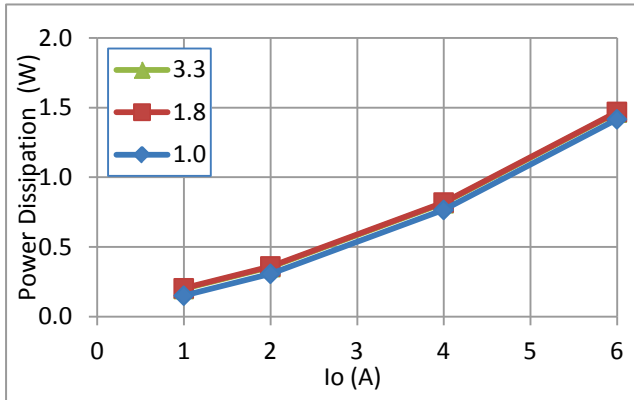

Figure 19 Vin = 5V Power Dissipation

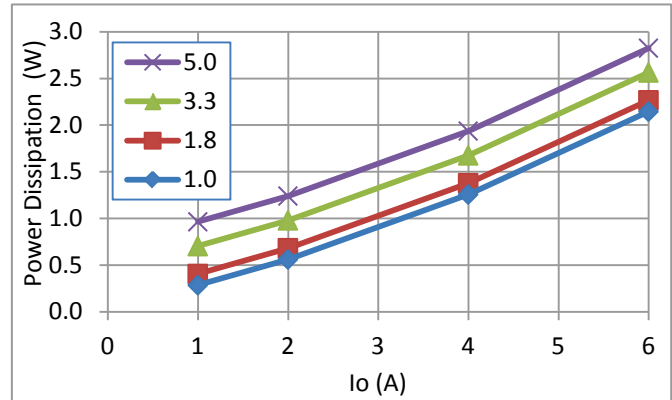

Figure 20 Vin = 12V Power Dissipation

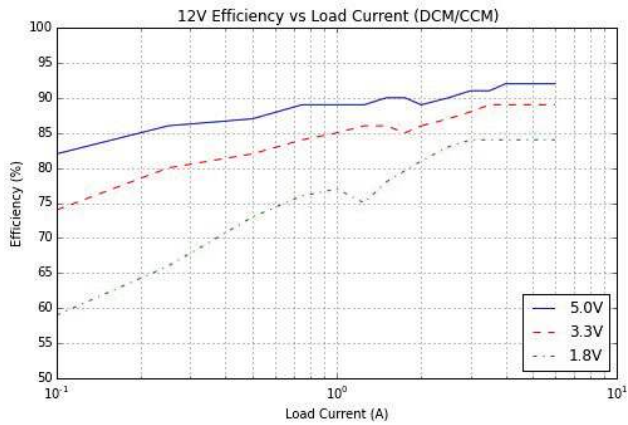

Figure 21 Efficiency, 12V_{IN}, 600kHz



A New Direction in Mixed-Signal

XRP9710 and XRP9711

Dual 6A Programmable Power Module

FUNCTIONAL OVERVIEW

The XRP9710 is a digital pulse width modulation (DPWM) power module with two 6A converters. In addition, the XRP9711 provides two additional PWM controller outputs which can directly drive external power stage. Each output voltage can be programmed from 0.6V to 5.5V without the need for an external voltage divider. The wide range of programmable DPWM switching frequencies (from 124 kHz to 1.23 MHz) enables the user to optimize for efficiency or component sizes. Since the digital regulation loop requires no external passive components, loop performance is not compromised due to external component variation or operating conditions.

The XRP9710/1 provides a number of critical safety features, such as Over-Current Protection (OCP), Over-Voltage Protection (OVP), Over-Temperature Protection (OTP) plus input Under-Voltage Lockout (UVLO). In addition, a number of key health monitoring features including warning level flags for the safety functions, Power Good (PGOOD), plus full monitoring of system voltages and currents. The above are all programmable and/or readable from the SMBus and many are steerable to the GPIOs for hardware monitoring.

For hardware communication, the XRP9710/1 has two logic level General Purpose Input-Output (GPIO) pins and three, 15V, open-drain, Power System Input-Output (PSIO) pins. Two pins are dedicated to the SMBus data (SDA) and clock (SCL).

The 5V LDO is used for internal power and is also optionally available to power external circuitry.

The primary benefit of these modules is the ultra small footprint and height, but these come with a full suite of advanced power management capabilities. All outputs are independently programmable which provides the user full control of the delay, ramp rate, and sequence during power up and power down. The user may also control how the outputs interact and power down in the event of a fault. This includes active ramp down of the output voltages to take down an output voltage as quickly as possible. Another useful feature is that the outputs can be defined and controlled as groups.

The XRP9710/1 has two main types of programmable memory. The first type is runtime registers that contain configuration, control and monitoring information for the chip. The second type is rewritable Non-Volatile Flash Memory (NVFM) that is used for permanent storage of the configuration data along with various chip internal functions. During power up, the run time registers are loaded from the NVFM allowing for standalone operation.

The XRP9710/1 brings an extremely high level of functionality and performance to a programmable power system. Ever decreasing product budgets require the designer to quickly analyze cost/performance tradeoffs to be truly successful. By incorporating four switching channels, a user LDO, and internal gate drivers, all in a single package, the XRP9710/1 allows for extremely cost effective power system designs. Another key cost factor that is often overlooked is the unanticipated Engineering Change Order (ECO). The programmable versatility of the XRP9710/1, along with the lack of hard wired, on board configuration components, allows for minor and major changes to be made on the board by simple reprogramming.

THEORY OF OPERATION

CHIP ARCHITECTURE

REGULATION LOOPS

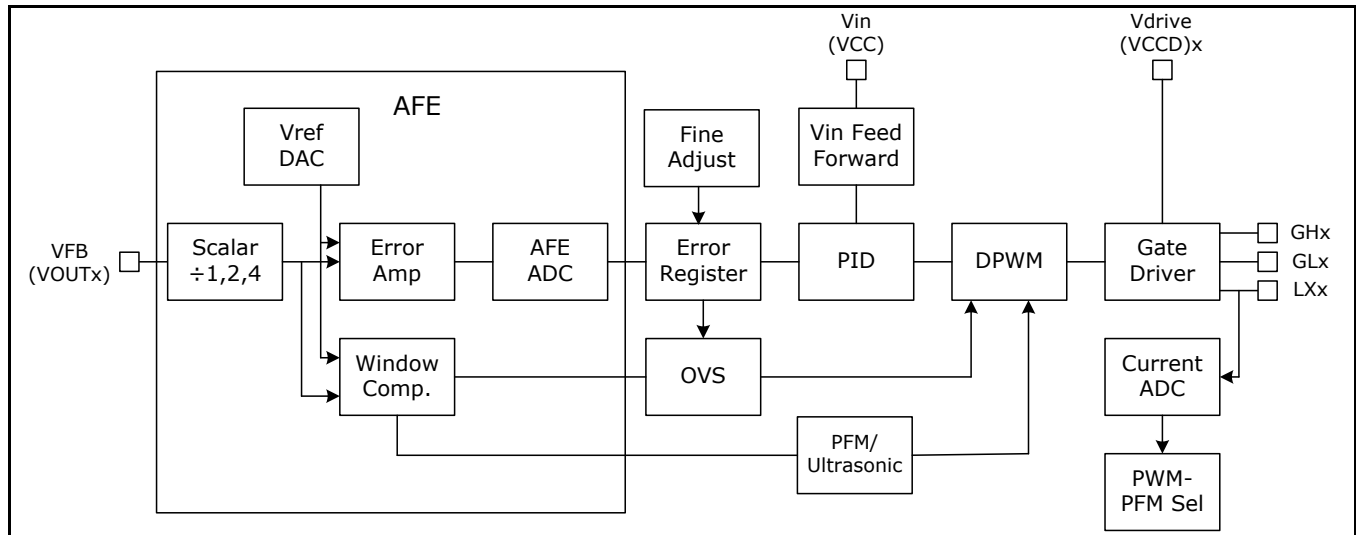

Figure 22 XRP9710 Regulation Loops

Figure 22 shows a functional block diagram of the regulation loops for an output channel. There are four separate parallel control loops; Pulse Width Modulation (PWM), Pulse Frequency Modulation (PFM), Ultrasonic, and Over Sampling (OVS). Each of these loops is fed by the Analog Front End (AFE) as shown at the left of the diagram. The AFE consist of an input voltage scaler, a programmable Voltage Reference (Vref) DAC, Error Amplifier, and a window comparator. (Please note that the block diagram shown is simplified for ease of understanding. Some of the functional blocks are common and shared by each channel by means of a multiplexer.)

PWM Loop

The PWM loop operates in Voltage Control Mode (VCM) with optional V_{IN} feed forward based on the voltage at the V_{CC} pin. The reference voltage (Vref) for the error amp is generated by a 0.15V to 1.6V DAC that has a 12.5mV resolution. In order to provide a full 0.6V to 5.5V output voltage range, an input scaler is used to reduce feedback voltages for higher output voltages to bring them within the 0.15V to 1.6V control range. So for output

voltages up to 1.6V (low range) the scaler has a gain of 1. For output voltages from 1.6V to 3.2V (mid range) the scaler gain is 1/2 and for voltages greater than 3.2V (high range) the gain is 1/4. This results in the low range having a reference voltage resolution of 12.5mV, the mid range having a resolution of 25mV and the high range having a resolution of 50mV. The error amp has a gain of 4 and compares the output voltage of the scaler to Vref to create an error voltage on its output. This is converted to a digital error term by the AFE ADC and is stored in the error register. The error register has a fine adjust function that can be used to improve the output voltage set point resolution by a factor of 5 resulting in a low range resolution of 2.5mV, a mid range resolution of 5mV and a high range resolution of 10mV. The output of the error register is then used by the Proportional Integral Derivative (PID) controller to manage the loop dynamics.

The XRP9710/1 PID is a 17-bit five-coefficient control engine that calculates the required duty cycle under the various operating conditions and feeds it to the Digital Pulse Width Modulator (DPWM). Besides the normal



A New Direction in Mixed-Signal

XRP9710 and XRP9711

Dual 6A Programmable Power Module

coefficients the PID also uses the V_{IN} voltage to provide a feed forward function.

The XRP9710/1 DPWM includes a special delay timing loop that provides a timing resolution that is 16 times the master oscillator frequency (103MHz) for a timing resolution of 607ps for both the driver pulse width and dead time delays. The DPWM produces the Gate High (GH) and Gate Low (GL) signals for the driver. The maximum and minimum on-times and dead time delays are programmable by configuration resistors.

To provide current information, the output inductor current is measured by a differential amplifier that reads the voltage drop across the R_{DS} of the lower FET during its on time. There are two selectable ranges, a low range with a gain of 8 for a +20mV to -120 mV range, and a high range with a gain of 4 for a +40mV to -280mV range. The optimum range to use will depend on the maximum output current and the R_{DS} of the lower FET. The measured voltage is then converted to a digital value by the current ADC block. The resulting current value is stored in a readable register, and also used to determine when PWM to PFM transitions should occur.

PFM mode loop

The XRP9710/1 has a PFM loop that can be enabled to improve efficiency at light loads. By reducing switching frequency and operating in the discontinuous conduction mode (DCM), both switching and I^2R losses are minimized.

Figure 23 shows a functional diagram of the PFM logic.

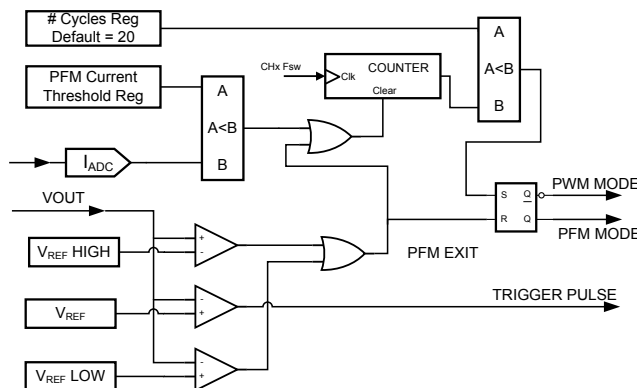

Figure 23 PFM Enter/Exit Functional Diagram

The PFM loop works in conjunction with the PWM loop and is entered when the output current falls below a programmed threshold level for a programmed number of cycles. When PFM mode is entered, the PWM loop is disabled and instead, the scaled output voltage is compared to V_{ref} with a window comparator. The window comparator has three thresholds; normal (V_{ref}), high ($V_{ref} + \%high$) and low ($V_{ref} - \%low$). The $\%high$ and $\%low$ values are programmable and track V_{ref} .

In PFM mode, the normal comparator is used to regulate the output voltage. If the output voltage falls below the V_{ref} level, the comparator is activated and triggers the DPWM to start a switching cycle. When the high side FET is turned on, the inductor current ramps up which charges up the output capacitors and increases their voltage. After the completion of the high side and low side on-times, the lower FET is turned off to inhibit any inductor reverse current flow. The load current then discharges the output capacitors until the output voltage falls below V_{ref} and the normal comparator is activated. This triggers the DPWM to start the next switching cycle. The time from the end of the switching cycle to the next trigger is referred to as the dead zone. When PFM mode is initially entered the switching duty cycle is equal to the steady-state PWM duty cycle. This will cause the inductor ripple current to be the same level that it was in PWM mode. During operation the PFM duty cycle is calculated based on the ratio of the output voltage to V_{CC} . This method ensures that the output voltage ripple is well controlled and is much lower than other architectures which use a "burst" methodology.

If the output voltage goes outside the high/low windows, PFM mode is exited and the PWM loop is reactivated.

Although the PFM mode is effective at improving efficiency at light load, at very light loads the dead zone time can increase to the point where the switching frequency can enter the audio hearing range. When this happens some components, like the output inductor and ceramic capacitors, can emit audible



A New Direction in Mixed-Signal

XRP9710 and XRP9711

Dual 6A Programmable Power Module

noise. The amplitude of the noise depends mainly on the board design and on the manufacturer and construction details of the components. Proper selection of components can reduce the sound to very low levels. In general Ultrasonic Mode is not used unless required as it reduces light load efficiency.

Ultrasonic Mode

Ultrasonic mode is an extension of PFM to ensure that the switching frequency never enters the audible range. When this mode is entered, the switching frequency is set to 30kHz and the duty cycle of the upper and lower FETs, which are fixed in PFM mode, are decreased as required to keep the output voltage in regulation while maintaining the 30kHz switching frequency.

Under extremely light or zero load currents, the GH on time pulse width can decrease to its minimum width. When this happens, the lower FET on time is increased slightly to allow a small amount of reverse inductor current to flow back into V_{IN} to keep the output voltage in regulation while maintaining the switching frequency above the audio range.

Oversampling OVS Mode

Oversampling (OVS) mode is a feature added to the XRP9711 to improve transient response for the two external channels. This mode can only be enabled when the channel switching frequency is operating in 1x frequency mode. In OVS mode the output voltage is sampled four times per switching cycle and is monitored by the AFE window comparators. If the voltage goes outside the set high or low limits, the OVS control electronics can immediately modify the pulse width of the GH or GL drivers to respond accordingly, without having to wait for the next cycle to start. OVS has two types of response depending on whether the high limit is exceeded during an unloading transient (Over Voltage), or the low limit is exceeded during a loading transient (Under Voltage).

Under Voltage OVS: If there is an increasing current load step, the output voltage will drop until the regulator loop adapts to the new conditions to return the voltage to the correct

level. Depending on where in the switching cycle the load step happens there can be a delay of up to one switching cycle before the control loop can respond. With OVS enabled if the output voltage drops below the lower level, an immediate GH pulse will be generated and sent to the driver to increase the output inductor current toward the new load level without having to wait for the next cycle to begin. If the output voltage is still below the lower limit at the beginning of the next cycle, OVS will work in conjunction with the PID to insert additional GH pulses to quickly return the output voltage back within its regulation band. The result of this system is transient response capabilities on par or exceeding those of a constant on-time control loop.

Over Voltage OVS: When there is a step load current decrease, the output voltage will increase (bump up) as the excess inductor current that is no longer used by the load flows into the output capacitors causing the output voltage to rise. The voltage will continue to rise until the inductor current decreases to the new load current. With OVS enabled, if the output voltage exceeds the high limit of the window comparator, a blanking pulse is generated to truncate the GH signal. This causes inductor current to immediately begin decreasing to the new load level. The GH signal will continue to be blanked until the output voltage falls below the high limit. Again, since the output voltage is sampled at four times the switching frequency, over shoot will be decreased and the time required to get back into the regulation band is also decreased.

OVS can be used in conjunction with both the PWM and PFM operating modes. When it is activated it can noticeably decrease output voltage excursions when transitioning between PWM and PFM modes.



A New Direction in Mixed-Signal

XRP9710 and XRP9711

Dual 6A Programmable Power Module

LDOS

The XRP9710/1 has an internal Low Drop-Out (LDO) linear regulator that generates 5.0V (LDO5) for both internal and external use. LDO5 is the main power input to the device and is supplied by an external 5.5V to 25V V_{CC} supply. The 5V output is used by the XRP9710/1 as a standby power supply and supply power to the 5V gate drivers. The total output current that the 5V LDO can provide is 130mA. The XRP9710/1 consumes

approximately 20mA and the rest is the gate drive currents. *During initial power up, the maximum external load should be limited to 30mA.*

For operation with a V_{CC} of 4.75V to 5.5V, the LDO5 output needs to be connected directly to V_{CC} on the board.

CLOCKS AND TIMING

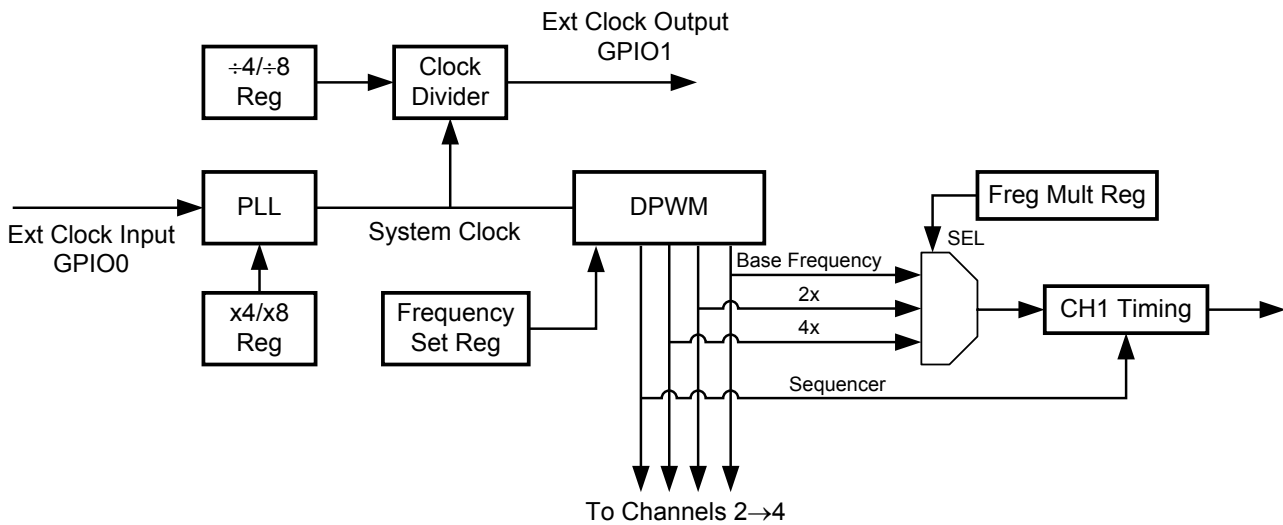

Figure 24 XRP9710 Timing Block Diagram

Figure 24 shows a simplified block diagram of the XRP9710/1 timing. Again, please note that the function blocks and signal names used are chosen for ease of understanding and do not necessarily reflect the actual design.

The system timing is generated by a 103MHz internal system clock (Sys_Clk). There are two ways that the 103MHz system clock can be generated. These include an internal oscillator and a Phase Locked Loop (PLL) that is synchronized to an external clock input. The basic timing architecture is to divide the Sys_Clk down to create a fundamental switching frequency (Fsw_Fund) for all the output channels that is settable from 124kHz to 306kHz. The switching frequency for a channel (Fsw_CHx) can then be selected as 1 time, 2 times or 4 times the fundamental switching frequency.

To set the base frequency for the output channels, an "Fsw_Set" value representing the base frequency shown in Table 1, is entered into the switching frequency configuration register. Note that Fsw_Set value is basically equal to the Sys_Clk divided by the base frequency. The system timing is then created by dividing down Sys_Clk to produce a base frequency clock, 2X and 4X times the base frequency clocks, and sequencing timing to position the output channels relative to each other. Each output channel then has its own frequency multiplier register that is used to select its final output switching frequency.

Table 1 shows the available channel switching frequencies for the XRP9710/1 device. The shaded areas show the allowable frequencies of the internal power stages. In practice the PowerArchitect™ 5.1 (PA 5.1) design tool



A New Direction in Mixed-Signal

XRP9710 and XRP9711 Dual 6A Programmable Power Module

handles all the details and the user only has to enter the fundamental switching frequency and the 1x, 2x, 4x frequency multiplier for each channel.

If an external clock is used, the frequencies in this table will shift accordingly.

Base Frequency kHz	Available 2x Frequencies kHz	Available 4x Frequencies kHz
123.8	247.6	495.2
126.2	252.5	504.9
128.8	257.5	515.0
131.4	262.8	525.5
134.1	268.2	536.5
137.0	273.9	547.9
139.9	279.9	559.8
143.1	286.1	572.2
146.3	292.6	585.2
149.7	299.4	598.8
153.3	306.5	613.1
157.0	314.0	628.0
160.9	321.9	643.8
165.1	330.1	660.3
169.4	338.8	677.6
174.0	348.0	695.9
178.8	357.6	715.3
183.9	367.9	735.7
189.3	378.7	757.4
247.6	495.2	990.4
257.5	515.0	1030.0
268.2	536.5	1072.9
279.9	559.8	1119.6
292.6	585.2	1170.5
306.5	613.1	1226.2

Table 1

SUPERVISORY AND CONTROL

Power system design with XRP9710/1 is accomplished using PA 5.1 design tool. All figures referenced in the following sections are taken from PA 5.1. Furthermore, the following sections reference I²C commands. For more information on these commands, refer to ANP-38. XRP9710/1 is supported with the commands listed in ANP-38 with the exception of XRP9710 using only the channel 3 and 4 related commands.

DIGITAL I/O

XRP9710/1 has two General Purpose Input Output (GPIO) and three Power System Input Output (PSIO) user configurable pins.

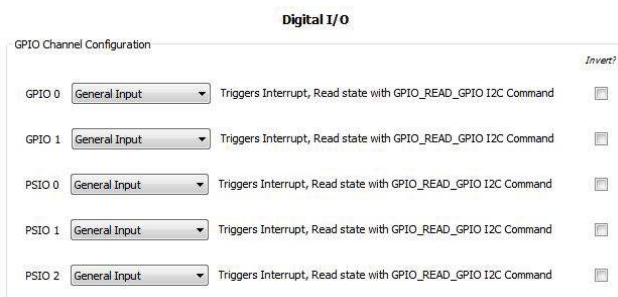

- GPIOs are 3.3V CMOS logic compatible and 5V tolerant.
- PSIOs which configured as outputs are open drain and require external pull-up resistors. These I/Os are 3.3V and 5V CMOS logic compatible, and up to 15V capable.

The polarity of the GPIO/PSIO pins is set in PA 5.1 or with an I²C command.

Configuring GPIO/PSIOs

The following functions can be controlled from or forwarded to any GPIO/PSIO:

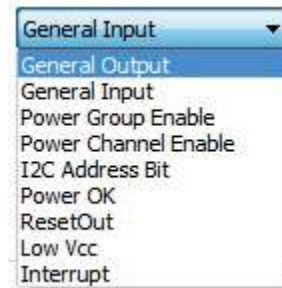

- **General Output** – set with an I²C command
- **General Input** – triggers an interrupt; state read with an I²C command
- **Power Group Enable** – controls enabling and disabling of Group 1 and Group 2.
- **Power Channel Enable** – controls enabling and disabling of an individual channel.
- **I²C Address Bit** – controls an I²C address bit.
- **Power OK** – indicates that selected channels have reached their target levels and have not faulted. Multiple channel selection is available, in which case the resulting signal is the AND logic function of all channels selected.
- **ResetOut** – is delayed Power OK. Delay is programmable in 1msec increments with the range of 0 to 255 msecs.
- **Low Vcc** – indicates when Vcc has fallen below the UVLO fault threshold and when the UVLO condition clears (Vcc voltage rises above the UVLO warning level).
- **Interrupt** – the controller generated interrupt selection and clearing is done through I²C commands.

Interrupt, Low Vcc, Power OK and ResetOut signals can only be forwarded to a single GPIO/PSIO.

In addition, the following are functions that are unique to GPIO0 and GPIO1.

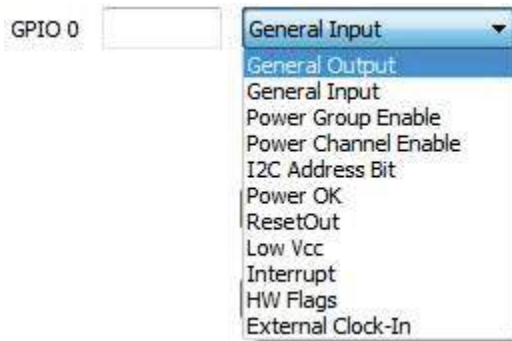

voltage against its user defined Power Good threshold limits (Power Good minimum and maximum levels). It has no hysteresis. Multiple channel selections will be combined using the AND logic function of all channels selected.



The Power Good minimum and maximum levels are expressed as percentages of the target voltage.

- HW Flags** – these are hardware monitoring functions forwarded to GPIO0 only. The functions include Under-Voltage Warning, Over-Temperature Warning, Over-Voltage Fault, Over-Current Fault and Over-Current Warning for every channel. Multiple selections will be combined using the OR logic function.

PGood Max (%)

PGood Min (%)

“PGood Max” is the upper window and “PGood Min” is the lower window. The minimum and maximum for each of these values can be calculated with the following equation:

$$PGOOD(\%) = \frac{N * LSB(mV) * 10^5}{V_{target} (V)}$$

Where N=1 to 63 for the PGOOD Max value and N=1 to 62 for the PGOOD Min value. For example, with the target voltage of 1.5V and set point resolution of 2.5mV (LSB), the Power Good min and max values can range from 0.17% to 10.3% and 0.17% to 10.5% respectively. A user can effectively double the range by changing to the next higher output voltage range setting, but at the expense of reduced set point resolution.

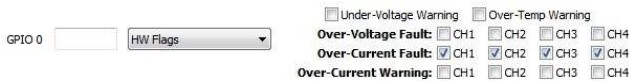

- External Clock-out** – clock sent out through GPIO1 for synchronizing with another XRP9710/1 (see the clock out section for more information).

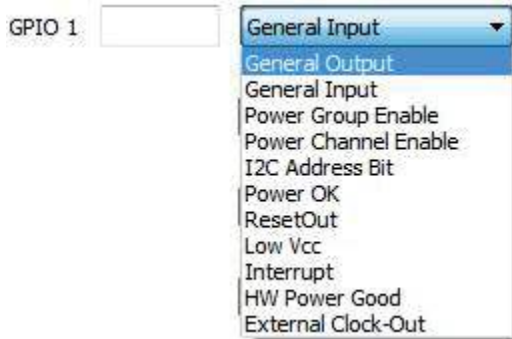

FAULT HANDLING

There are six different types of fault handling:

- HW Power Good** – the Power Good hardware monitoring function. It can only be forwarded to GPIO1. This is an output voltage monitoring function that is a hardware comparison of channel output

- Under Voltage Lockout (UVLO)** monitors voltage supplied to the Vcc pin and will cause the controller to shut down



all channels if the supply drops to critical levels.

- **Over Temperature Protection (OTP)** monitors temperature of the chip and will cause the controller to shut down all channels if temperature rises to critical levels.
- **Over Voltage Protection (OVP)** monitors regulated voltage of a channel and will cause the controller to react in a user specified way if the regulated voltage surpasses threshold level.
- **Over Current Protection (OCP)** monitors current of a channel and will cause the controller to react in a user specified way if the current level surpasses threshold level.
- **Start-up Time-out Fault** monitors whether a channel gets into regulation in a user defined time period
- **LDO5 Over Current Protection (LDO5 OCP)** monitors current drawn from the regulator and will cause the controller to be reset if the current exceeds LDO5 limit

UVLO

Both UVLO warning and fault levels are user programmable and set at 200mV increments in PA 5.1.

UVLO Warning (V) UVLO Fault (V)

When the warning level is reached the controller will generate the UVLO_WARNING_EVENT interrupt. In addition, the host can be informed about the event through HW Flags on GPIO0 (see the Digital I/O section).

When an under voltage fault condition occurs, the XRP9710/1 outputs are shut down and the UVLO_FAULT_ACTIVE_EVENT interrupt is generated. In addition, the host can be informed by forwarding the Low Vcc signal to any GPIO/PSIO (see the Digital I/O section). This signal transitions when the UVLO fault occurs. When coming out of the fault, rising Vcc crossing the UVLO fault level will trigger the UVLO_FAULT_INACTIVE_EVENT interrupt.

Once the UVLO condition clears (Vcc voltage rises above or to the user-defined UVLO

warning level), the Low Vcc signal will transition and the controller will be reset.

Special attention needs to be paid in the case when Vcc = LDO5 = 4.75V to 5.5V. Since the input voltage ADC resolution is 200mV, the UVLO warning and fault set points are coarse for a 5V input. Therefore, setting the warning level at 4.8V and the fault level at 4.6V may result in the outputs not being re-enabled until a full 5.0V is reached on Vcc. Setting the warning level to 4.6V and the fault level at 4.4V would likely make UVLO handling as desired; however, at a fault level below 4.6V the device has a hardware UVLO on LDO5 to ensure proper shutdown of the internal circuitry of the controller. This means the 4.4V UVLO fault level may never occur.

OTP

User defined OTP warning, fault and restart levels are set at 5°C increments in PA 5.1.

OTP Warning (°C) OTP Fault (°C)
 Enable Temp. Monitoring in Standby Mode OTP Restart Threshold (°C)

When the warning level is reached the controller will generate the TEMP_WARNING_EVENT interrupt. In addition, the host can be informed about the event through HW Flags on GPIO0 (see the Digital I/O section).

When an OTP fault condition occurs, the XRP9710/1 outputs are shut down and the TEMP_OVER_EVENT interrupt is generated.

Once temperature reaches a user defined OTP Restart Threshold level, the TEMP_UNDER_EVENT interrupt will be generated and the controller will reset.

OVP

A user defined OVP fault level is set in PA 5.1 and is expressed in percentages of a regulated target voltage.

OVP (%)

Resolution is the same as for the target voltage (expressed in percentages). The OVP minimum and maximum values are calculated



A New Direction in Mixed-Signal

XRP9710 and XRP9711

Dual 6A Programmable Power Module

by the following equation where the range for N is 1 to 63:

$$OVP(\%) = \frac{N * LSB(mV) * 10^5}{V_{target}(V)}$$

When the OVP level is reached and the fault is generated, the host will be notified by the SUPPLY_FAULT_EVENT interrupt generated by the controller. The host then can use an I²C command to check which channel is at fault.

In addition, OVP fault can be monitored through GPIO0.

A user can choose one of three options in response to an OVP event: shutdown the faulting channel, shut down faulting channel and perform auto-restart of the channel, or restart the chip.

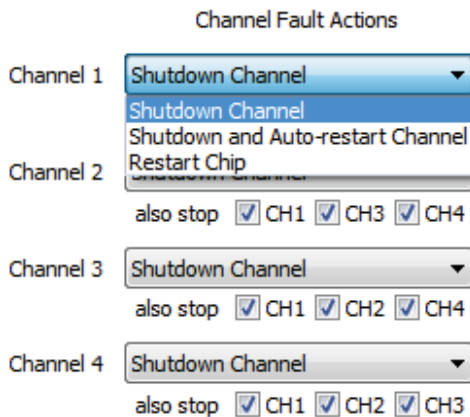

In the case of shutting down the faulting channel and auto-restarting, the user has an option to specify startup timeout (the time in which the fault is validated) and hiccup timeout (the period after which the controller will try to restart the channel) periods in 1 msec increments with a maximum value of 255 msec.

Startup Timeout (ms)	Hiccup Timeout (ms)
100	100
100	100
100	100
100	100

Note: The Channel Fault Action response is the same for an OVP or OCP event.

OCP

A user defined OCP fault level is set with 10 mA increments in PA 5.1. PA 5.1 uses calculations to give the user the approximate DC output current entered in the current limit field. However the actual current limit trip value programmed into the part is limited to 280mV as defined in the electrical characteristics. The maximum value the user can program is limited by R_{ds(on)} of the synchronous Power FET and current monitoring ADC range. For example, using a synchronous FET with R_{DS(ON)} of 30mΩ, and the wider ADC range, the maximum current limit programmed would be:

$$OCP\ Max(A) = \frac{280mV}{30m\Omega} = 9.33A$$

The current is sampled approximately 30ns before the low side MOSFET turns off, so the actual measured DC output current in this example would be 9.33A plus approximately half the inductor ripple.

An OCP Fault is considered to have occurred only if the fault threshold has been tripped in four consecutive switching cycles. When the switching frequency is set to the 4x multiplier, the current is sampled only every other cycle. As a result it can take as many as eight switching cycles for an over current event to

be detected. When operating in 4x mode an inductor with a soft saturation characteristic is recommended.

When the OCP level is reached and the fault is generated, the host will be notified by the SUPPLY_FAULT_EVENT interrupt generated by the controller. The host then can use an I²C command to check which channel is at fault.

In addition, OCP faults can be monitored through HW Flags on GPIO0. The host can also monitor the OCP warning flag through HW Flags on GPIO0. The OCP warning level is calculated by PA 5.1 as 85% of the OCP fault level.

A user can choose one of three options in response to an OCP event: shutdown the faulting channel, shut down faulting channel and perform auto-restart of the channel, or restart the chip.

The output current reported by the XRP9710/1 is processed through a seven sample median filter in order to reduce noise. The OCP limit is compared against unfiltered ADC output.

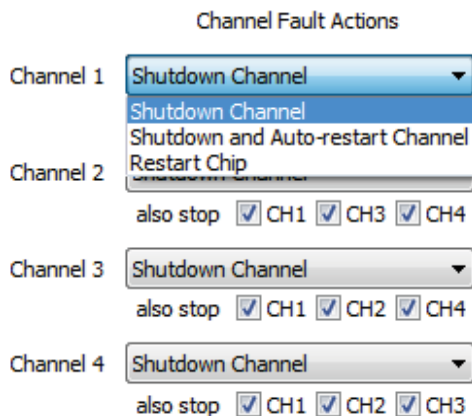

For the case of Shutdown and Auto-restart Channel, the user has an option to specify startup timeout (the time in which the fault is validated) and hiccup timeout (the period after which the controller will try to restart the channel) periods in 1 msec increments with a maximum value of 255 msec.

Note: The Channel Fault Action response is the same for an OVP or OCP event.

Start-up Time-out Fault

A channel will be at Startup Timeout Fault if it does not come-up in the time period specified in the "Startup Timeout" box. In addition, a channel is at Startup Timeout Fault if its pre-bias configuration voltage is within a defined value too close to the target.

When the fault is generated, the host will be notified by the SUPPLY_FAULT_EVENT interrupt generated by the controller. The host then can use an I²C command to check which channel is at fault.

LDO5 OCP

When current is drawn from the LDO5 that exceeds the LDO5 current limit the controller will be reset.

EXTERNAL CLOCK SYNCHRONIZATION

XRP9710/1 can be run off an external clock available in the system or another XRP9710/1. The external clock must be in the ranges of 10.9MHz to 14.7MHz or 21.8MHz to 29.6MHz. Locking to the external clock is done through an internal Phase Lock Loop (PLL).

The external clock must be routed to GPIO0. The GPIO0 setting must reflect the range of the external clock applied to it: Sys_Clock/8 corresponds to the range of 10.9MHz to 14.7MHz while Sys_Clock/4 setting corresponds to the range of 21.8MHz to 29.6MHz.

The functionality is enabled in PA 5.1 by selecting External Clock-in function under GPIO0.



For more details on how to monitor PLL lock in-out, please contact Exar or your local Exar representative.

CLOCK OUT

XRP9710/1 can supply clock out to be used by another XRP9710/1 controller. The clock is routed out through GPIO1 and can be set to system clock divided by 8 (Sys_Clock/8) or system clock divided by 4 (Sys_Clock/4) frequencies.

The functionality is enabled in PA 5.1 by selecting External Clock-Out function under GPIO1.



CHANNEL CONTROL

Channels can be controlled independently by any GPIO/PSIO or I²C command. Channels will start-up or shut-down following transitions of signals applied to GPIO/PSIOs set to control the channels. The control can always be overridden with an I²C command.

Regardless of whether the channels are controlled independently or are in a group, the ramp rates will be followed as specified (see the Power Sequencing section).

Regulated voltages and voltage drops across the synchronous FET on each switching channel can be read back using I²C commands. The regulated voltage read back resolution is 15mV, 30mV and 60mV per LSB depending on the target voltage range. The voltage drop across synchronous FET read back resolution is 1.25mV and 2.5mV per LSB depending on the range.

Through an I²C command the host can check the status of the channels; whether they are in regulation or at fault.

Regulated voltages can be dynamically changed on switching channels using I²C commands with resolution of 2.5mV, 5mV and 10mV depending on the target voltage range (in PWM mode only).

For more information on I²C commands please refer to ANP-38 or contact Exar or your local Exar representative.

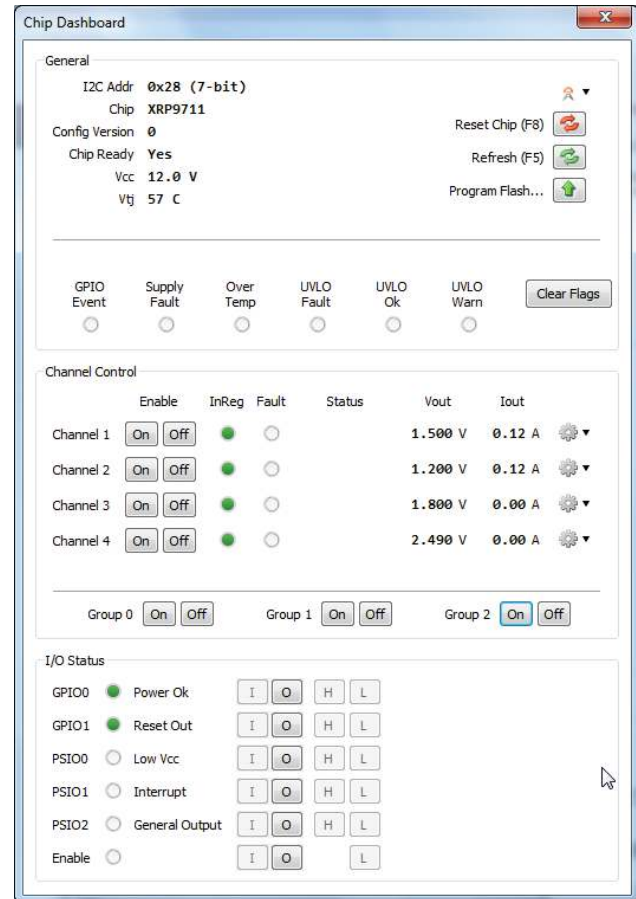

POWER SEQUENCING

All channels can be grouped together and will start-up and shut-down in a user defined sequence.

Selecting none means the channel will not be assigned to any group and therefore will be controlled independently.

Group Selection

Power Enable Groups	None	Group 0 (@ Chip Enable)	Group 1	Group 2
Channel 1	<input type="radio"/>	<input type="radio"/>	<input checked="" type="radio"/>	<input type="radio"/>
Channel 2	<input type="radio"/>	<input type="radio"/>	<input checked="" type="radio"/>	<input type="radio"/>
Channel 3	<input type="radio"/>	<input type="radio"/>	<input checked="" type="radio"/>	<input type="radio"/>
Channel 4	<input type="radio"/>	<input type="radio"/>	<input type="radio"/>	<input checked="" type="radio"/>

There are three groups:

- **Group 0** – is controlled by the chip ENABLE or an I²C command. Channels assigned to this group will come up with the ENABLE signal being high (plus additional delay needed to load configuration from Flash to run-time



A New Direction in Mixed-Signal

XRP9710 and XRP9711

Dual 6A Programmable Power Module

registers), and will go down with the ENABLE signal being low. The control can always be overridden with an I²C command.

Since it is recommended to leave the ENABLE pin floating in the applications when V_{cc} = LDO5 = 4.75V to 5.5V, please contact Exar for how to configure the channels to come up at the power up in this scenario.

- **Group 1** – can be controlled by any GPIO/PSIO or I²C command. Channels assigned to this group will start-up or shut-down following transitions of a signal applied to the GPIO/PSIO set to control the group. The control can always be overridden with an I²C command.
- **Group 2** – can be controlled by any GPIO/PSIO or I²C command. Channels assigned to this group will start-up or shut-down following transitions of a signal applied to the GPIO/PSIO set to control the group. The control can always be overridden with an I²C command.

Start-up

Start-up				Group 0			Group 1			Group 2		
Channel	Ramp Rate (ms/V)	Order	Wait	Delay (ms)	Order	Wait	Delay (ms)	Order	Wait	Delay (ms)		
		PGOOD?			PGOOD?			PGOOD?				
Channel 1	4.858	0	<input type="checkbox"/>	0	1	<input type="checkbox"/>	0	0	<input type="checkbox"/>	0		
Channel 2	4.858	0	<input type="checkbox"/>	0	2	<input type="checkbox"/>	0	0	<input type="checkbox"/>	0		
Channel 3	5.020	0	<input type="checkbox"/>	0	0	<input type="checkbox"/>	0	1	<input type="checkbox"/>	0		
Channel 4	5.020	0	<input type="checkbox"/>	0	0	<input type="checkbox"/>	0	2	<input type="checkbox"/>	0		

For each channel within a group, a user can specify the following start-up characteristics:

- **Ramp Rate** – expressed in milliseconds per volt.
- **Order** – position of a channel to come-up within the group
- **Wait PGOOD?** – selecting this option for a channel means the next channel in the order will not start ramping-up until this channel reaches the target level and its Power Good flag is asserted.
- **Delay** – an additional time delay a user can specify to postpone a channel start-up with respect to the previous channel in the order. The delay is expressed in milliseconds with a range of 0msec to 255msec.

Shut-down

Shutdown				Group 0			Group 1			Group 2		
Channel	Ramp Rate (ms/V)	Order	Wait	Delay (ms)	Order	Wait	Delay (ms)	Order	Wait	Delay (ms)		
		StopThresh?			StopThresh?			StopThresh?				
Channel 1	4.858	0	<input type="checkbox"/>	0	1	<input type="checkbox"/>	0	0	<input type="checkbox"/>	0		
Channel 2	4.858	0	<input type="checkbox"/>	0	2	<input type="checkbox"/>	0	0	<input type="checkbox"/>	0		
Channel 3	5.020	0	<input type="checkbox"/>	0	0	<input type="checkbox"/>	0	1	<input type="checkbox"/>	0		
Channel 4	5.020	0	<input type="checkbox"/>	0	0	<input type="checkbox"/>	0	2	<input type="checkbox"/>	0		

For each channel within a group a user can specify the following shut-down characteristics:

- **Ramp Rate** – expressed in milliseconds per volt.
- **Order** – position of a channel to come-down within the group
- **Wait Stop Thresh?** – selecting this option for a channel means the next channel in the order will not start ramping-down until this channel reaches the Stop Threshold level. The stop threshold level is fixed at 600mV.
- **Delay** – additional time delay a user can specify to postpone a channel shut-down with respect to the previous channel in the order. The delay is expressed in milliseconds with a range of 0msec to 255msec.

MONITORING V_{CC} AND TEMPERATURE

Through I²C commands, the host can read back the voltage applied to the V_{cc} pin and the die temperature respectively. The V_{cc} read back resolution is 200mV per LSB; the die temperature read back resolution is 5C° per LSB. For more on I²C commands please refer to ANP-38.

PROGRAMMING XRP9710/1

XRP9710/1 is a FLASH based device which means its configuration can be programmed into FLASH NVM and re-programmed a number of times.

Programming of FLASH NVM is done through PA 5.1.



A New Direction in Mixed-Signal

XRP9710 and XRP9711

Dual 6A Programmable Power Module

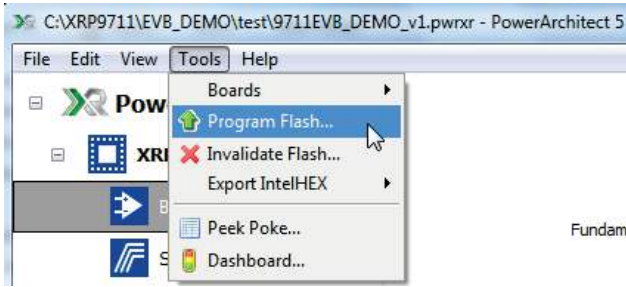

XRP9710

The XRP9710 differs from the XRP9711 in that it eliminates the two external power stages but adds differential voltage sensing of the two remaining outputs. However, the two remaining channels remain designated 3 and 4. Below in the PA 5.1 Dashboard, one can see Channels 1 and 2 grayed out when using a XRP9710. This methodology also ensures code development is easily ported between the two devices.

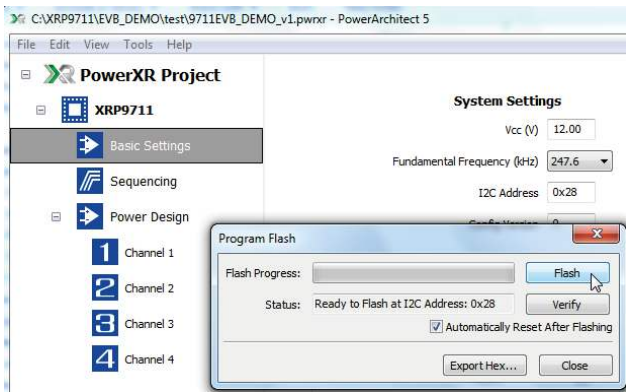

By clicking on the Flash button, the user will start the programming sequence of the design configuration into the Flash NVM. After the programming sequence completes, the chip will reset (if automatically reset After Flashing box is checked) and boot the design configuration from the Flash.

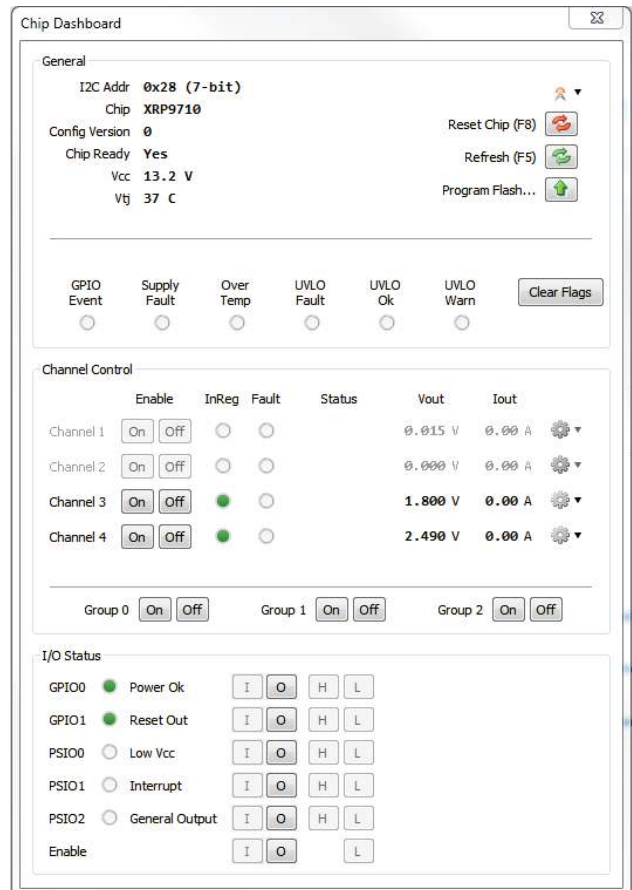
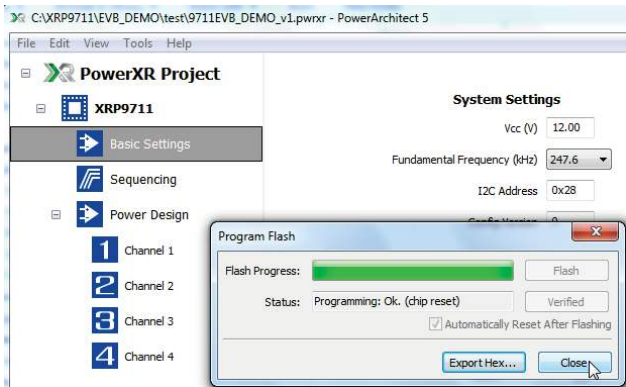

Users who wish to create their own programming procedure so they can re-program Flash in-circuit using their system software should contact Exar for a list of needed I²C Flash Commands.



A New Direction in Mixed-Signal

XRP9710 and XRP9711

Dual 6A Programmable Power Module

ENABLING XRP9710/1

XRP9710/1 has a weak internal pull-up ensuring it becomes enabled as soon as internal voltage supplies have ramped up and are in regulation.

Driving the Enable pin low externally will keep the controller in the shut-down mode. A simple open drain pull down is the recommended way to shut XRP9710/1 down.

If the Enable pin is driven high externally to control XRP9710/1 coming out of the shut-down mode, care must be taken to ensure the Enable pin is driven high after Vcc gets supplied to the controller.

In the configuration when $V_{cc} = LDO5 = 4.75V$ to $5.5V$, disabling the device by grounding the Enable pin is not recommended. It is recommended to leave the Enable pin floating and place the controller in the "Standby Mode" instead in this scenario. The standby mode is defined as the state when all switching channels are disabled, all GPIO/PSIOs are programmed as inputs, and the system clock is disabled. In this state the device consumes $440\mu A$ typically.

Short duration Enable pin toggled low

Short duration shutdown pulses to the ENABLE pin of the XRP9710/1, which do not provide sufficient time for the LDO5 voltage to fall below $3.5V$, can result in significant delay in re-enabling of the device. Some examples below show LDO5 and ENABLE pins:

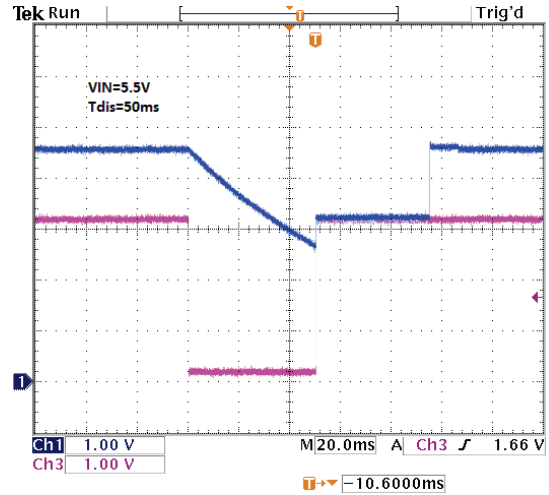

No load on LDO5, blue trace. Recovery time after the ENABLE logic high is approximately 40ms.

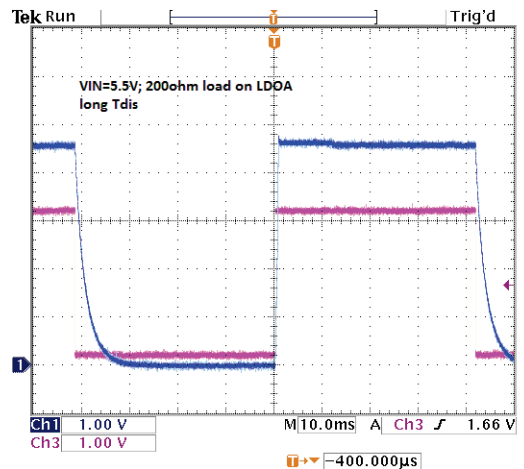

Adding a 200 ohm load on LDO5 pulls the voltage below $3.5V$ and the restart is short.

Note that as V_{CC} increases, the restart time falls as well. A $5.5V$ input voltage is shown as the worst case.

Since the ENABLE pin has an internal current source, a simple open drain pull down is the recommended way to shut down the XRP9710/1. A diode in series with a resistor between the LDO5 and ENABLE pins may offer a way to more quickly pull down the LDO5 output when the ENABLE pin is pulled low.

APPLICATION INFORMATION

THERMAL DESIGN

Proper thermal design is critical in controlling device temperatures and in achieving robust designs. There are a number of factors that affect the thermal performance. One key factor is the temperature rise of the devices in the package, which is a function of the thermal resistances of the devices inside the package and the power being dissipated (P_{DISS}).

The thermal resistance of the XRP9710/1 is shown in the "Operating Ratings" section of this datasheet. The JEDEC θ_{JA} thermal resistance provided is based on tests that comply with the JESD51-2A "Integrated Circuit Thermal Test Method Environmental Conditions - Natural Convection" standard. JESD51-xx are a group of standards whose intent is to provide comparative data based on a standard test condition which includes a defined board construction. Since the actual board design in the final application will be different from the board defined in the standard, the thermal resistances in the final design may be different from those shown.

The package thermal derating curve is shown in Figure 18. The total package power dissipation (P_{PKG}) is dependent on the final application design for channels three and four, and is the sum of the losses for the two channels. The power losses for a channel will depend mainly on the input voltage, output voltage, and output current. Figure 19 and Figure 20 show the power losses for input voltages of 5V and 12V respectively.

First, determine the package power derating for a maximum ambient temperature (T_{AMB})

using Figure 18. Then, based on the design input voltage, use Figures 19 or 20 accordingly.

For example:

Consider a two channel design that has a $T_{AMB} = 50^{\circ}\text{C}$, $V_{IN} = 12\text{V}$, $V_{OUT3} = 1\text{V}$, $V_{OUT4} = 3.3\text{V}$. Figure 18 shows P_{PKG} max is 4.1 Watts at 50°C . The result is that the sum of the power dissipation for both channels must be less than the 4.1W.

Figure 20 shows the power dissipation for $V_{IN} = 12\text{V}$ designs. If the 1V output current is 6A, then its P_{DISS} is 2.1W. This leaves 2W for the 3.3V channel. The graph shows that at 2W the maximum 3.3V output current would be 4.7A.

EMI EMISSIONS

The XRP9711 has been tested on the evaluation board and passes CISPR22 Level B radiated emissions.

LAYOUT GUIDELINES

Refer to application note ANP-32 "Practical Layout Guidelines for Power^{XR} Designs". These apply primarily to the two external power stages available on the XRP9711.

Also refer to the XRP9710 or XRP9711 Evaluation Board Manual for specifics in grounding and heat sinking.

BOARD ASSEMBLY

Detailed boards assembly information specifically to address the unique package requirement is available in ANP-45, LGA Module Assembly Application Note.



A New Direction in Mixed-Signal

XRP9710 and XRP9711

Dual 6A Programmable Power Module

PACKAGE SPECIFICATION

12MMX12MM LGA

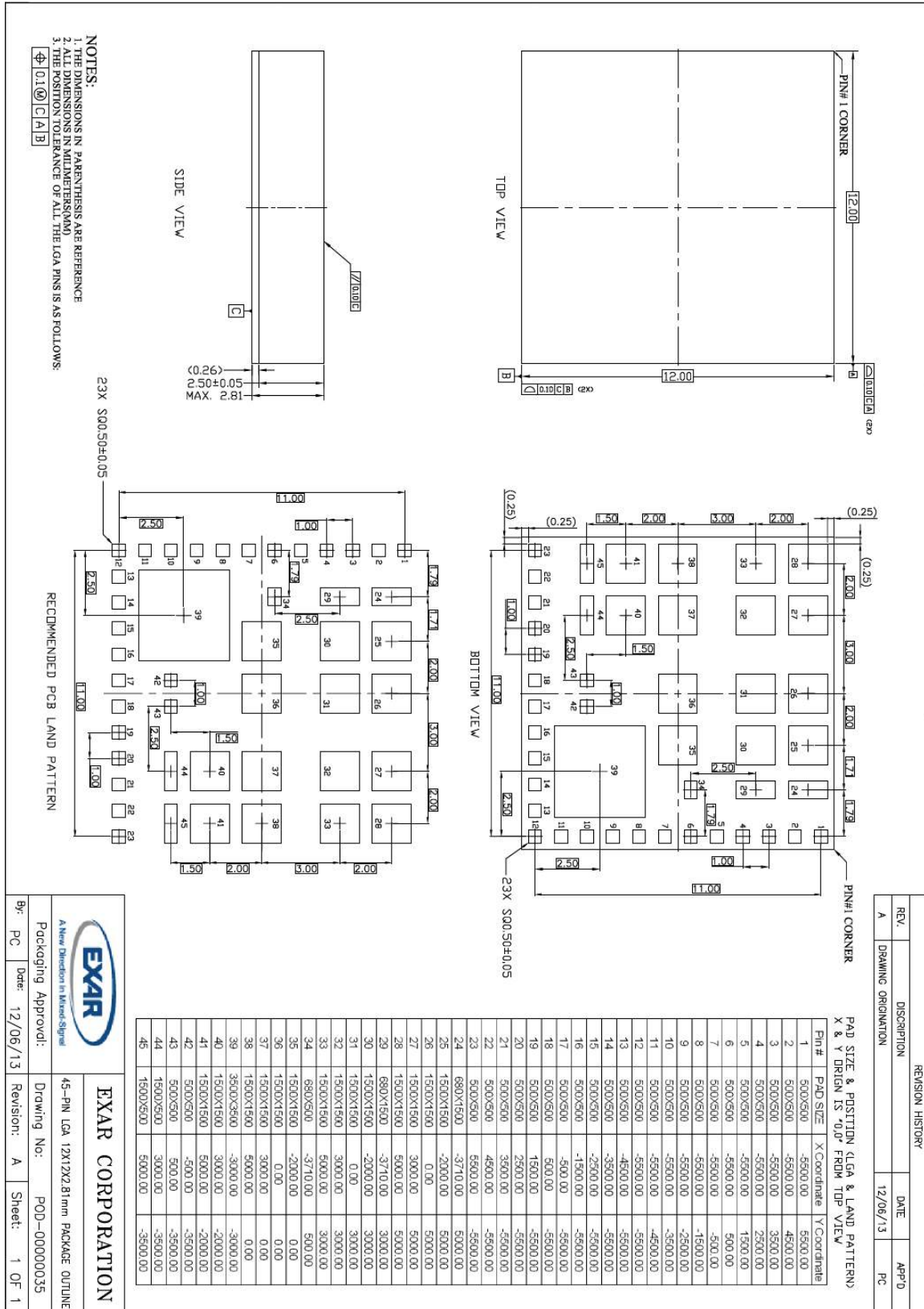



XRP9710 and XRP9711

Dual 6A Programmable Power Module

REVISION HISTORY

Revision	Date	Description
1.0.0	12/18/2013	Initial Release [ECN: 1352-06]
1.0.1	01/03/2014	Fix minor typographical items for consistency. Formatting updates. [ECN: 1402-03]
1.0.2	01/14/2014	Updated marking information in ordering table

FOR FURTHER ASSISTANCE

Email:

customersupport@exar.com

powertechsupport@exar.com

Exar Technical Documentation:

<http://www.exar.com/TechDoc/default.aspx?>



EXAR CORPORATION

HEADQUARTERS AND SALES OFFICES

48720 Kato Road

Fremont, CA 94538 – USA

Tel.: +1 (510) 668-7000

Fax: +1 (510) 668-7030

www.exar.com

NOTICE

EXAR Corporation reserves the right to make changes to the products contained in this publication in order to improve design, performance or reliability. EXAR Corporation assumes no responsibility for the use of any circuits described herein, conveys no license under any patent or other right, and makes no representation that the circuits are free of patent infringement. Charts and schedules contained herein are only for illustration purposes and may vary depending upon a user's specific application. While the information in this publication has been carefully checked; no responsibility, however, is assumed for inaccuracies.

EXAR Corporation does not recommend the use of any of its products in life support applications where the failure or malfunction of the product can reasonably be expected to cause failure of the life support system or to significantly affect its safety or effectiveness. Products are not authorized for use in such applications unless EXAR Corporation receives, in writing, assurances to its satisfaction that: (a) the risk of injury or damage has been minimized; (b) the user assumes all such risks; (c) potential liability of EXAR Corporation is adequately protected under the circumstances.

Reproduction, in part or whole, without the prior written consent of EXAR Corporation is prohibited.