

DATE	REV	ECN	APP'D. BY
12-15-15	C3	10480	TRM
3-30-16	C4	10653	TRM
2-18-21	C5	11698	JE

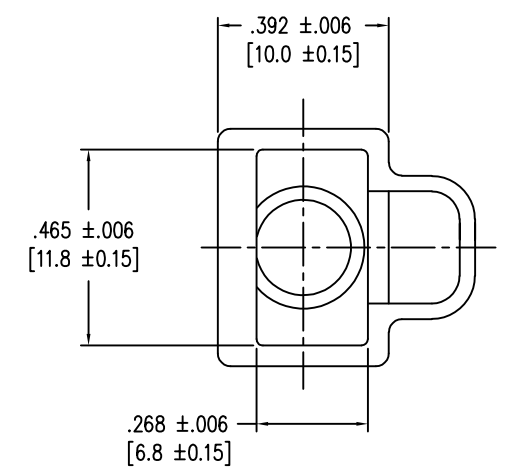

PART NUMBER	COLOR
450-011	BLACK
450-012	DARK GREY
450-013	YELLOW
450-014	GREEN
450-015	BLUE
450-016	LIGHT GREY
450-017	PURPLE
450-018	WHITE

NOTES:
 1. CONNECTOR MATERIALS:
 HOUSING: THERMOPLASTIC UL94 V-0

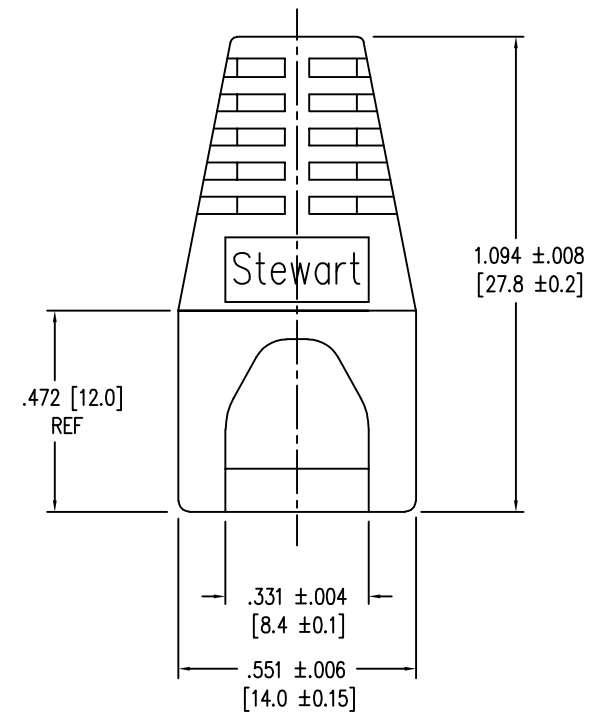
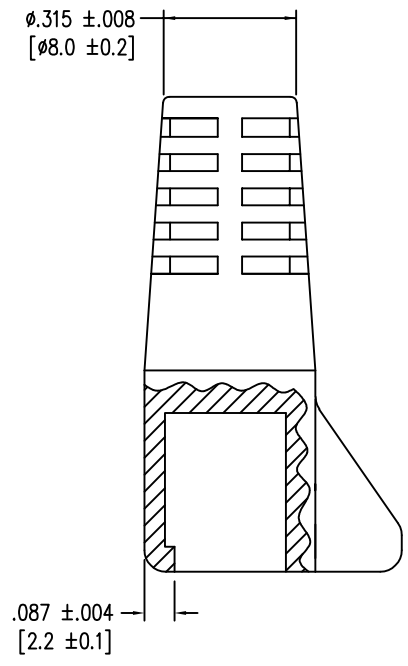
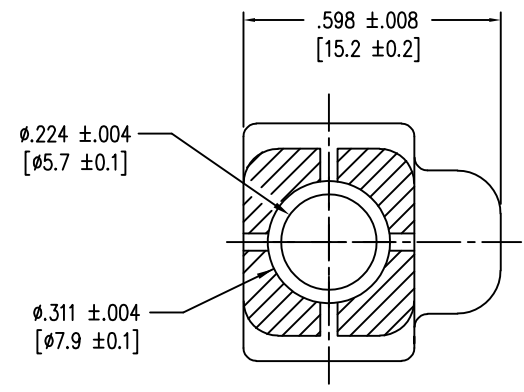

THIRD ANGLE PROJECTION 	 stewart CONNECTOR a bel group	11118 Susquehanna Trail South Glen Rock, PA 17327-9199 (717) 235-7512 http://www.stewartconnector.com
DO NOT SCALE DRAWING DRAWING IS SUBJECT TO CHANGE WITHOUT NOTICE	TITLE: EXTERNAL STRAIN RELIEF BOOT	
DIMENSIONS: INCHES [METRIC] UNLESS OTHERWISE SPECIFIED TOLERANCES ARE ±.005 [0.13] ANGLES ARE ± 1°	THIS DRAWING AND THE SUBJECT MATTER SHOWN THEREON ARE CONFIDENTIAL AND THE PROPRIETARY PROPERTY OF STEWART CONNECTOR AND SHALL NOT BE REPRODUCED, COPIED, OR USED IN ANY MANNER WITHOUT PRIOR WRITTEN CONSENT OF STEWART CONNECTOR. ONE OR MORE U.S. PATENTS MAY APPLY TO THIS PRODUCT. FOR DETAILS, PLEASE VISIT: HTTP://BELFUSE.COM/STEWART/STEWART_PATENTS/	DRN BY: DAB DATE 9/9/03 APPD BY: RGC DATE 9/12/03
SHEET NO. 1 OF 1	DWG NO. CT999002	REV. C5