

A6211 High-Current LED Driver Evaluation Board

The A6211 is a single IC switching regulator that provides constant-current output to drive high-power LEDs. It integrates a high-side N-channel DMOS switch for DC-to-DC step-down (buck) conversion. The A6211 EVB (evaluation board) accepts input voltage from 6 to 48 V to drive a single LED string. LED current can be from several hundred mA up to 3 A, selected by jumper combination on the EVB. Switching frequency is fixed at 1 MHz for the EVB, but it can be easily changed by changing a resistor (see A6211 datasheet for details).

Allegro offers Gerber files for this evaluation board on the following website (click on the tab labeled “Technical Docs”): <http://www.allegromicro.com/en/Products/Regulators-And-Lighting/LED-Drivers-For-Lighting/A6211.aspx>

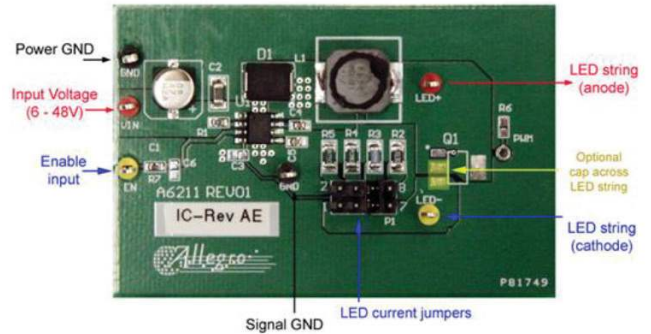

Figure 1: A6211 Evaluation Board

Quick Startup Guide

1. Connect an LED string between LED+ (anode) and LED- (cathode).
2. Insert or remove jumpers from P1 to select the appropriate LED current (see Table 1).
3. Connect input power between VIN and GND. For LED current regulation, the minimum input voltage should be at least 20% higher than the LED string’s operating voltage.
4. Connect EN (enable) to a logic high signal, or connect it to VIN. This will turn on the LED string.
5. For LED dimming: connect EN to a suitable PWM signal (such as 0-3V, 200 Hz 50%). Vary the PWM duty cycle between 1% and 100% to control the brightness of LED string.

Table 1: Jumper Settings vs. LED Current

Jumper 1-2	Jumper 3-4	Jumper 5-6	Jumper 7-8	Approximate LED Current (A)
ON	–	–	–	0.3
–	ON	–	–	0.5
–	–	ON	–	1.0
–	–	–	ON	1.5
–	ON	–	ON	2.0
–	–	ON	ON	2.5
–	ON	ON	ON	3.0

Note that due to contact resistance introduced by connectors and jumpers, the above current settings are approximate.

SCHEMATIC

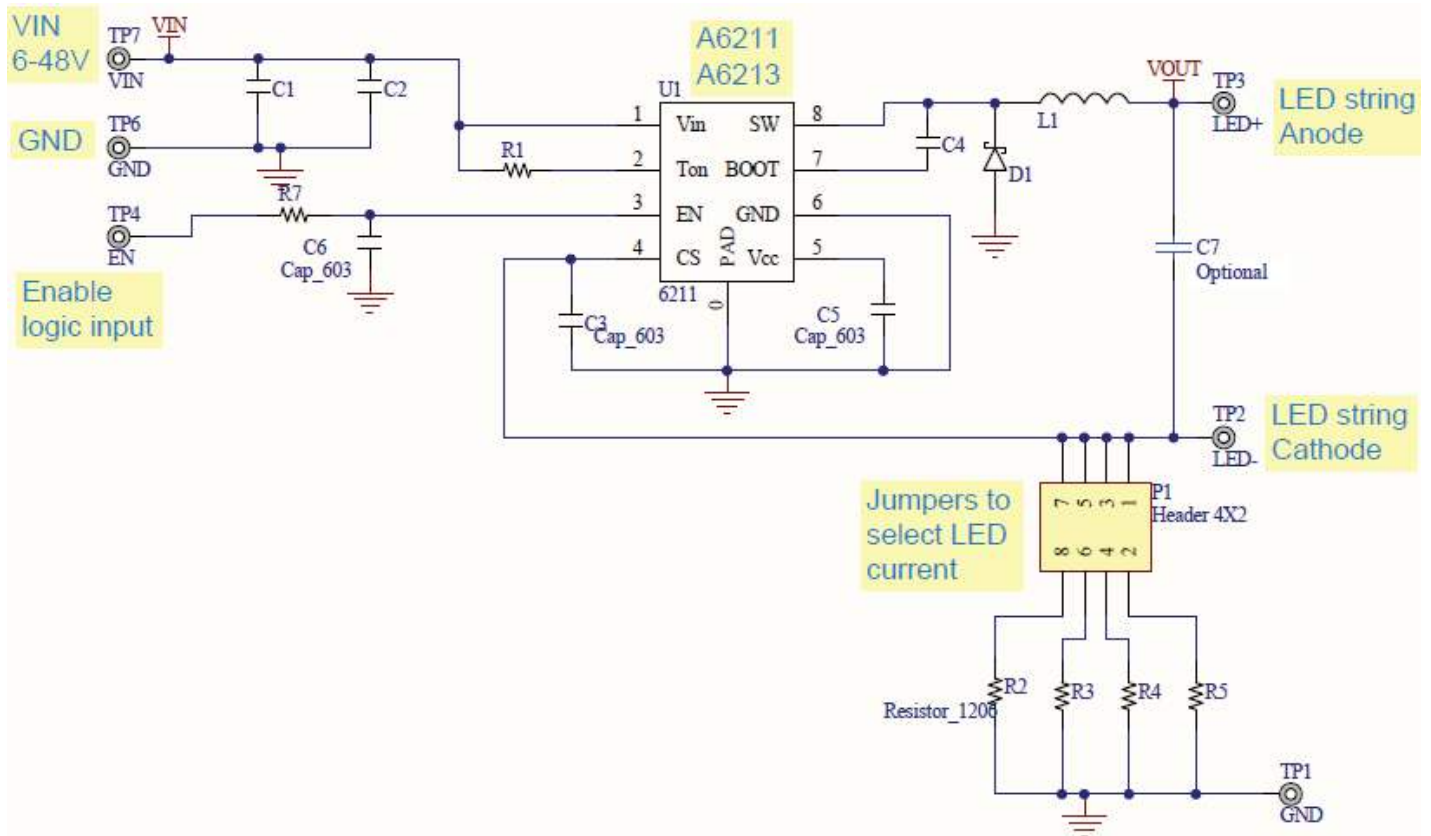

Figure 2: A6211 Evaluation Board Schematic

BILL OF MATERIALS

Reference	Quantity	Description	Footprint	Part Number	Notes
C1	1	CAP 47 μ F, 50 V, ELECT MZA SMD	Cap Radial 8 mm surface mount	565-2568-1-ND	V_{IN} filter electrolytic cap (exactly value not critical)
C2	0	CAP CER 10 μ F, 50 V, X5R 1210	Capacitor_1210	587-2225-1-ND	V_{IN} filter ceramic cap
	1	CAP CER 4.7 μ F, 50 V, X5R 1206	Capacitor_1206	587-1962-1-ND	
C3	0	0.1 μ F, 10 V, X7R, ceramic	Resistor_ Capacitor_0603	399-1095-1-ND	Optional, use in case of nosily sense line
C4	1	0.047 μ F, 50 V, X7R 0603	Resistor_ Capacitor_0603	445-5095-1-ND	BOOT cap
C5	1	0.1 μ F, 10 V, X7R ceramic	Resistor_ Capacitor_0603	399-1095-1-ND	V_{CC} filter cap
C6	0	10 nF, 50 V, X7R	Resistor_ Capacitor_0603	490-1511-1-ND	Optional input cap for EN (can be used for 10 k Ω pulldown resistor instead)
C7	0	2.2 μ F, 50 V, X5R	Capacitor_1206	587-2402-1-ND	Optional filter cap across LED string. Try 0.47 μ F to 4.7 μ F
D1	0	B350A-13-F DIODE SCHOTTKY 3 A, 50 V SMA	Diode_SMA	B350A-FDICT-ND	For LED current up to ~2 A
	1	B560C-13-F DIODE SCHOTTKY 5 A, 60 V SMC	Diode_SMC	B560C-FDICT-ND	For LED current up to 3 A
L1	0	VLF12060T- 220M4R1 (22 μ H, 4 A, 36 m Ω , 12 \times 11.7 \times 6 mm)	12 \times 12 mm	445-3595-1-ND	Use larger inductance for lower frequency and lower current
	1	B82464G4103M (10 μ H, 3.4 A, 10 \times 10 \times 5 mm)	10.4 \times 10.4 mm	5-1796-1-ND	Use smaller inductance for higher frequency and current
	0	NR8040T100M (10 μ H, 3.4 A, 20%, 44 m Ω , 8 \times 8 \times 4 mm)	8 \times 8 mm	587-2001-1-ND	8 mm inductor is only good for up to ~2 A LED current
P1	1	Header, 4-Pin, Dual Row	HDR2X4		
R1	1	63.4 k Ω , 0.1 W, 1%	603	P63.4KHKR-ND	R_{ON} = 63.4 k Ω gives f_{SW} = 1 MHz
	0	27.4 k Ω , 0.1 W, 1%	603	P27.4KHCT-ND	R_{ON} = 27.4 k Ω gives f_{SW} = 2 MHz
R2	1	0.13 Ω , 0.5 W, 1%	Resistor_1206	RL16R.13FCT-ND	~1.35 A (due to jumper resistance)
R3	1	0.20 Ω , 0.5 W, 1%	Resistor_1206	RL16R.20FCT-ND	~0.9 A
R4	1	0.39 Ω , 0.5 W, 1%	Resistor_1206	RL16R.39FCT-ND	~0.45 A
R5	1	0.75 Ω , 0.5 W, 1%	Resistor_1206	RL16R.75FCT-ND	~0.24 A
R7	1	1 k Ω , 0.1 W, 1%	Resistor_ Capacitor_0603	P1.0KDBCT-ND	Limits the input current in case $V_{EN} > V_{IN}$
EN, LED-	2	Test Point, Yellow	Test_Point	5014K-ND	
LED+, VIN	2	Test Point, Red	Test_Point	5010K-ND	
GND, GND1	2	Test Point, Black	Test_Point	5011K-ND	
U1	1	A6211/A6213	SOICN 8		Narrow SOIC-8 with exposed pad

Revision History

Number	Date	Description
–	November 11, 2016	Initial release

Copyright ©2016, Allegro MicroSystems, LLC

Allegro MicroSystems, LLC reserves the right to make, from time to time, such departures from the detail specifications as may be required to permit improvements in the performance, reliability, or manufacturability of its products. Before placing an order, the user is cautioned to verify that the information being relied upon is current.

Allegro's products are not to be used in any devices or systems, including but not limited to life support devices or systems, in which a failure of Allegro's product can reasonably be expected to cause bodily harm.

The information included herein is believed to be accurate and reliable. However, Allegro MicroSystems, LLC assumes no responsibility for its use; nor for any infringement of patents or other rights of third parties which may result from its use.

For the latest version of this document, visit our website:

www.allegromicro.com

