

1		2		3					4		5					6					7		8	
Material-No.	Order-No.	Shell Size / for No. of Contacts	A ±0.3	B ±0.1	C ±0.3	D ±0.3	E ±0.3	∅F1 min - max	max l	∅F2 Rubber bushing	G ±0.3	H ±0.3	J ±0.3	K ±0.3	L ±0.3	M ±0.5	N ±0.3	Q	R ±0.3	∅F1 = Cable diameter without rubber bushing	∅F2 = Cable diameter with rubber bushing			
1731110303	FMK1GX	1 / 9	14.9	25	31.6	39.5	15.2	3 - 9.5	6.5	FKT1-2	20.1	42	12.1	17	19.4	23.5	12	-	-					
1731110169	FMK2GX	2 / 15	15.9	33.3	40	41	15.2	3 - 8.5	6.5	FKT1-2	23.3	43.5	12.1	25.8	27.9	19	16	84°	-					
1731110367	FMK3GX	3 / 25	27.8	47	53.7	45	15.2	3 - 8.5	8	FKT1-2A	31.7	47.5	12.1	39	41.4	28	16	80°	12.9					
1731110277	FMK4GX	4 / 37	44.3	63.5	70.2	48	18.2	3 - 12	9	FKT3-4	48.2	50.5	15.1	55.5	57.8	32.5	21	80°	16.1					
1731110754	FMK5GX	5 / 50	41.9	61.1	67.8	48	18.2	3 - 12	9.7	FKT3-4A	45.8	50.5	15.1	53.1	55.5	32.5	21	80°	16.1					

view of the hoods without lid

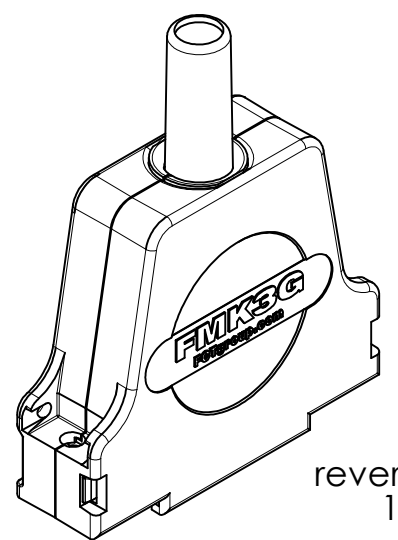
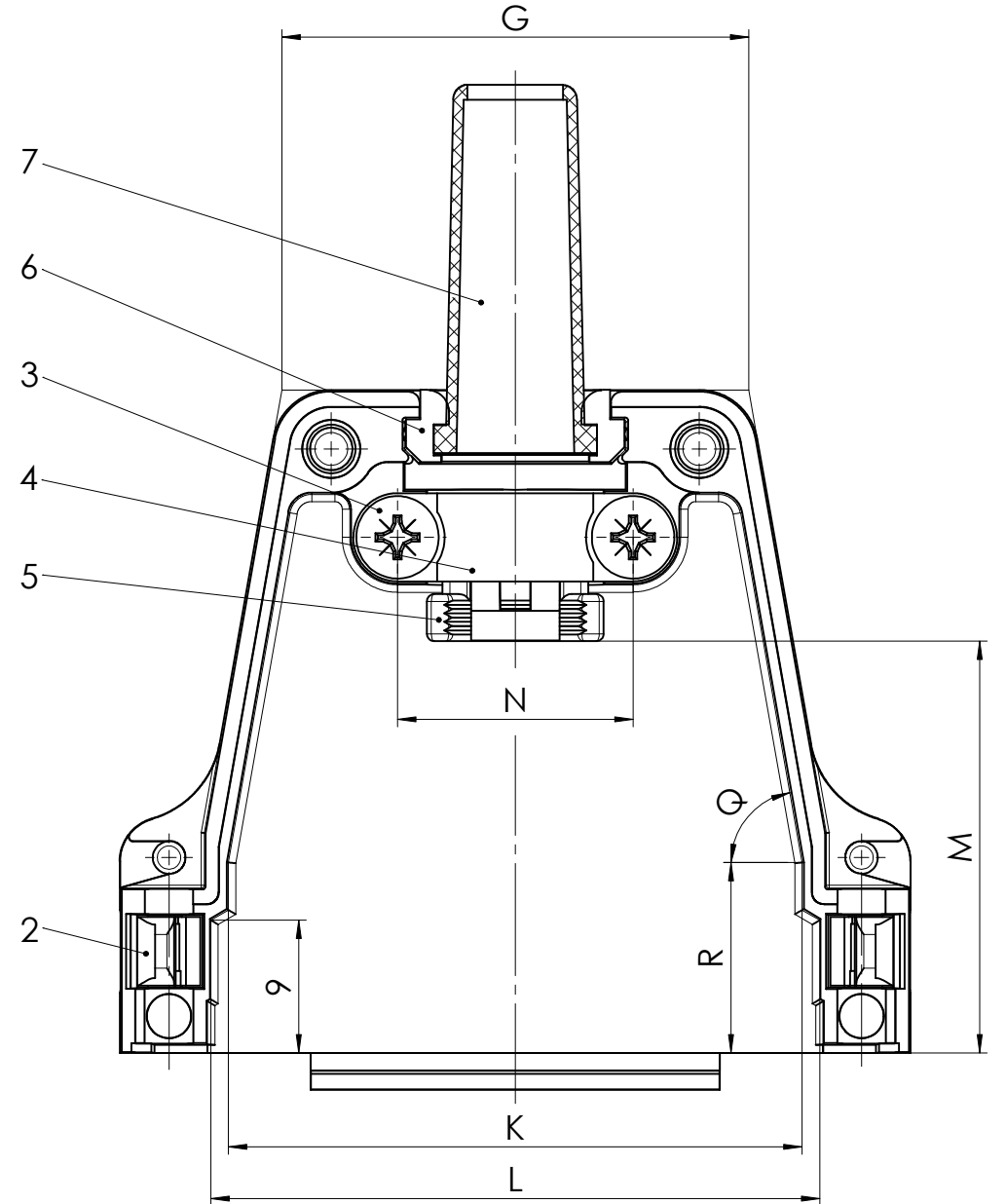
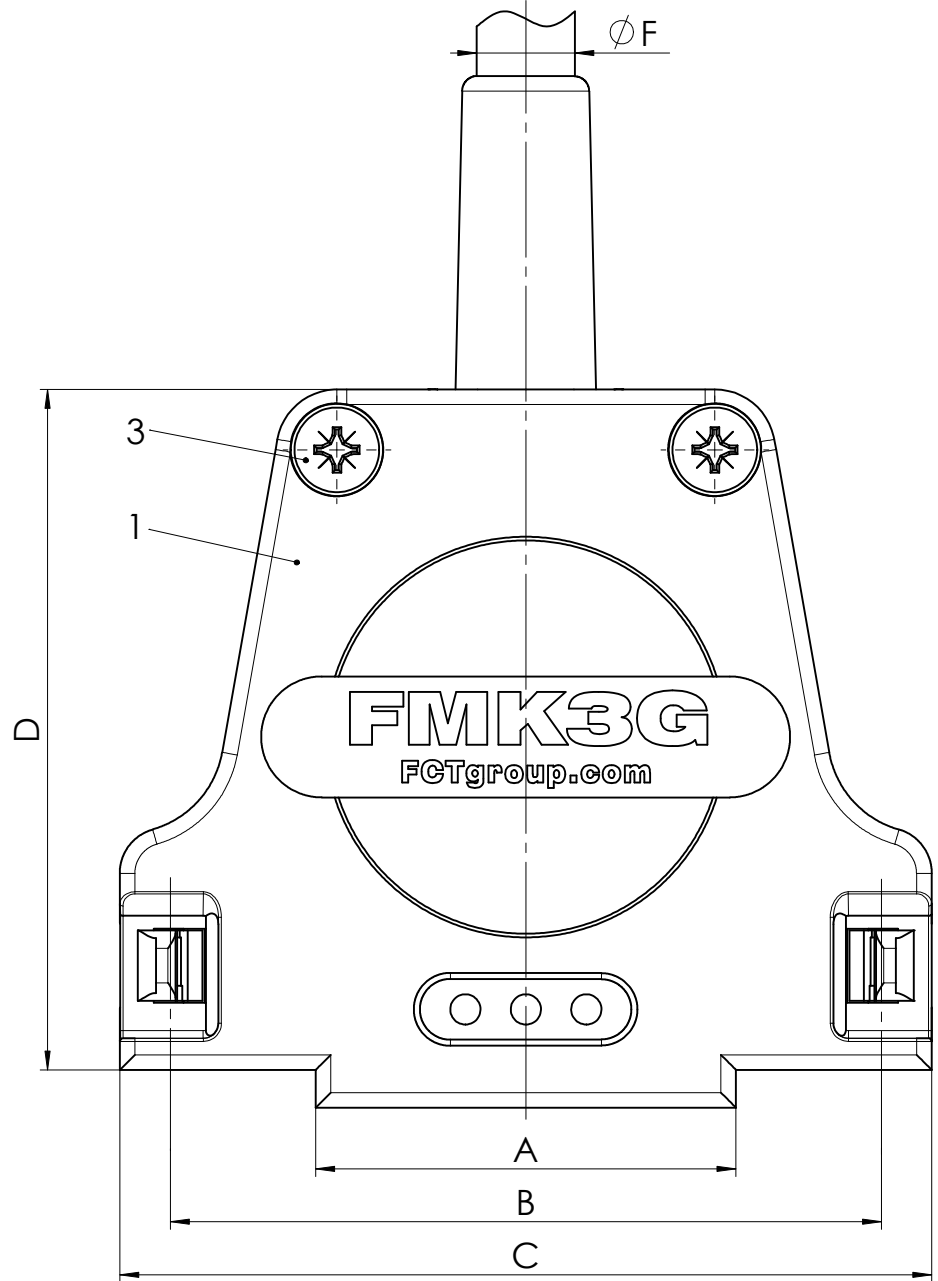
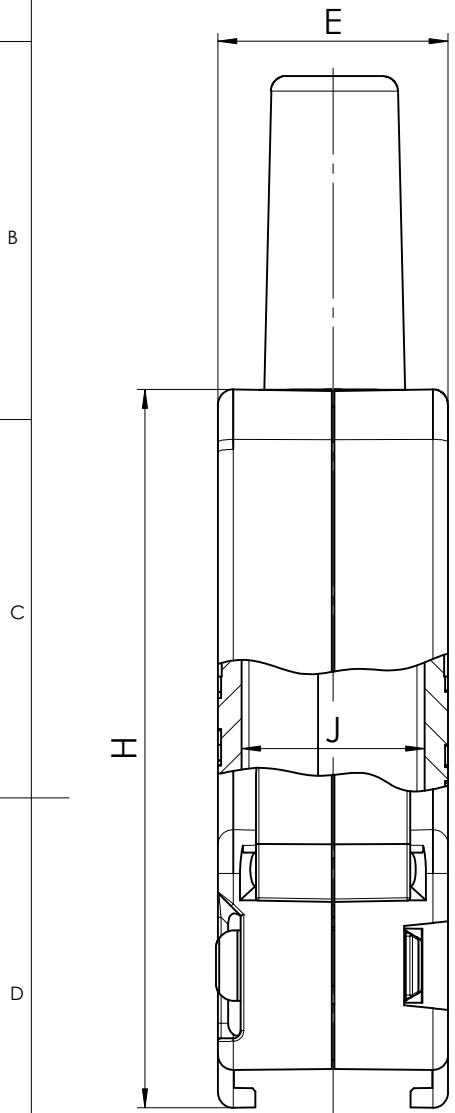

reverse side 1:1

RoHS compliant by exemption

max. torque are 40 Ncm
 Part-No. 7 not mounted
 FMK1GX with Part-No. 5 alternatively
 in Zinc die-cast, tin plated
 FMK1GX without Part-No. 6

No.	St.	Part	Type Description / Material	Surface plating / Colour / Class
7	1	Rubber bushing	TPE	black
6	0/2	Cable reduction plate	Zinc die-cast	nickel plated
5	1	Strain relief	ABS	nickel plated
4	1	Cable clamp	Steel	tin plated
3	4	Screw	Case hardened steel	zinc plated
2	2	Catch spring	PEI	black
1	1	Hood	FMK1-5G / Zinc die-cast	nickel plated

SYMBOLS					THIS DRAWING CONTAINS INFORMATION THAT IS PROPRIETARY TO MOLEX ELECTRONIC TECHNOLOGIES, LLC AND SHOULD NOT BE USED WITHOUT WRITTEN PERMISSION					
▽ = 0	▽ = 0	▽ = 0	▽ = 0	▽ = 0	DIMENSION UNITS	SCALE	MEASUREMENTS WITHOUT TOLERANCE ACC. TO	molex		
▽ = 0	▽ = 0	▽ = 0	▽ = 0	mm	2:1	ISO 2768-m				
▽ = 0	▽ = 0	▽ = 0	▽ = 0	▽ = 0	CURRENT REVISION					
▽ = 0	▽ = 0	▽ = 0	▽ = 0	▽ = 0	DRWN: DRAWN BY ameyerrichte 19-03-2019					
▽ = 0	▽ = 0	▽ = 0	▽ = 0	▽ = 0	APPR: APPR BY MWild 19-03-2019					
▽ = 0	▽ = 0	▽ = 0	▽ = 0	▽ = 0	INITIAL REVISION					
▽ = 0	▽ = 0	▽ = 0	▽ = 0	▽ = 0	8	24131	DRWN: DRAWN BY cpasch 28-08-2006		MATERIAL NUMBER	
▽ = 0	▽ = 0	▽ = 0	▽ = 0	▽ = 0	7	24071	APPR: APPR BY gkrimschndl 28-08-2006		see table	
▽ = 0	▽ = 0	▽ = 0	▽ = 0	▽ = 0	REV.	CH.-NO.	REPLACEMENT FOR: FMK1-5GXq_ACAD		DOCUMENT NUMBER	
▽ = 0	▽ = 0	▽ = 0	▽ = 0	▽ = 0	THIRD ANGLE PROJECTION		DRAWING A3-SIZE		FMK1-5GX	
▽ = 0	▽ = 0	▽ = 0	▽ = 0	▽ = 0	CUSTOMER GENERAL MARKET					REVISION
▽ = 0	▽ = 0	▽ = 0	▽ = 0	▽ = 0						8
▽ = 0	▽ = 0	▽ = 0	▽ = 0	▽ = 0						SHEET NUMBER
▽ = 0	▽ = 0	▽ = 0	▽ = 0	▽ = 0						1 OF 1

COMMENT: ALL RIGHTS ARE RESERVED BY US FOR THIS DRAWING. WITHOUT OUR PRIOR CONSENT, IT MAY NEITHER BE DUPLICATED NOR MADE AVAILABLE TO A THIRD PARTY. AND IT ALSO MAY NOT BE IMPROPERLY USED BY THE RECEIVER, OR A THIRD PARTY.